

(19) **United States**

(12) **Patent Application Publication**
NGUYEN et al.

(10) **Pub. No.: US 2021/0205044 A1**

(43) **Pub. Date: Jul. 8, 2021**

(54) **LIGAMENT RETRACTOR**

Publication Classification

(71) Applicant: **Optimotion Implants LLC**, Orlando, FL (US)

(51) **Int. Cl.**
A61B 90/00 (2006.01)
A61B 17/02 (2006.01)

(72) Inventors: **Vuong Binh NGUYEN**, Windermere, FL (US); **Dinesh V. KOKA**, Winter Springs, FL (US)

(52) **U.S. Cl.**
 CPC *A61B 90/08* (2016.02); *A61B 17/025* (2013.01); *A61B 2017/0046* (2013.01); *A61B 2017/0268* (2013.01); *A61B 2090/08021* (2016.02)

(73) Assignee: **Optimotion Implants LLC**, Orlando, FL (US)

(57) **ABSTRACT**

(21) Appl. No.: **17/211,530**

A retractor assembly may include a retractor removably coupled with a retractor handle. The retractor may include a handle connection feature, a retractor shaft, an arcuate projection having a convex retractor surface and a cutting shield surface, and a guide projection having an aperture shaped to receive at least a portion of a femoral condyle therein to position the retractor relative to a tibial plateau. The retractor handle may include a handle portion and a retractor connection feature. The retractor may be placed on a lateral side of a medial collateral ligament of a knee joint to retract the medial collateral ligament away from a tibial plateau of the knee joint and protect the medial collateral ligament during a tibial plateau resection procedure.

(22) Filed: **Mar. 24, 2021**

Related U.S. Application Data

(63) Continuation-in-part of application No. 16/803,501, filed on Feb. 27, 2020.

(60) Provisional application No. 62/812,245, filed on Feb. 28, 2019.

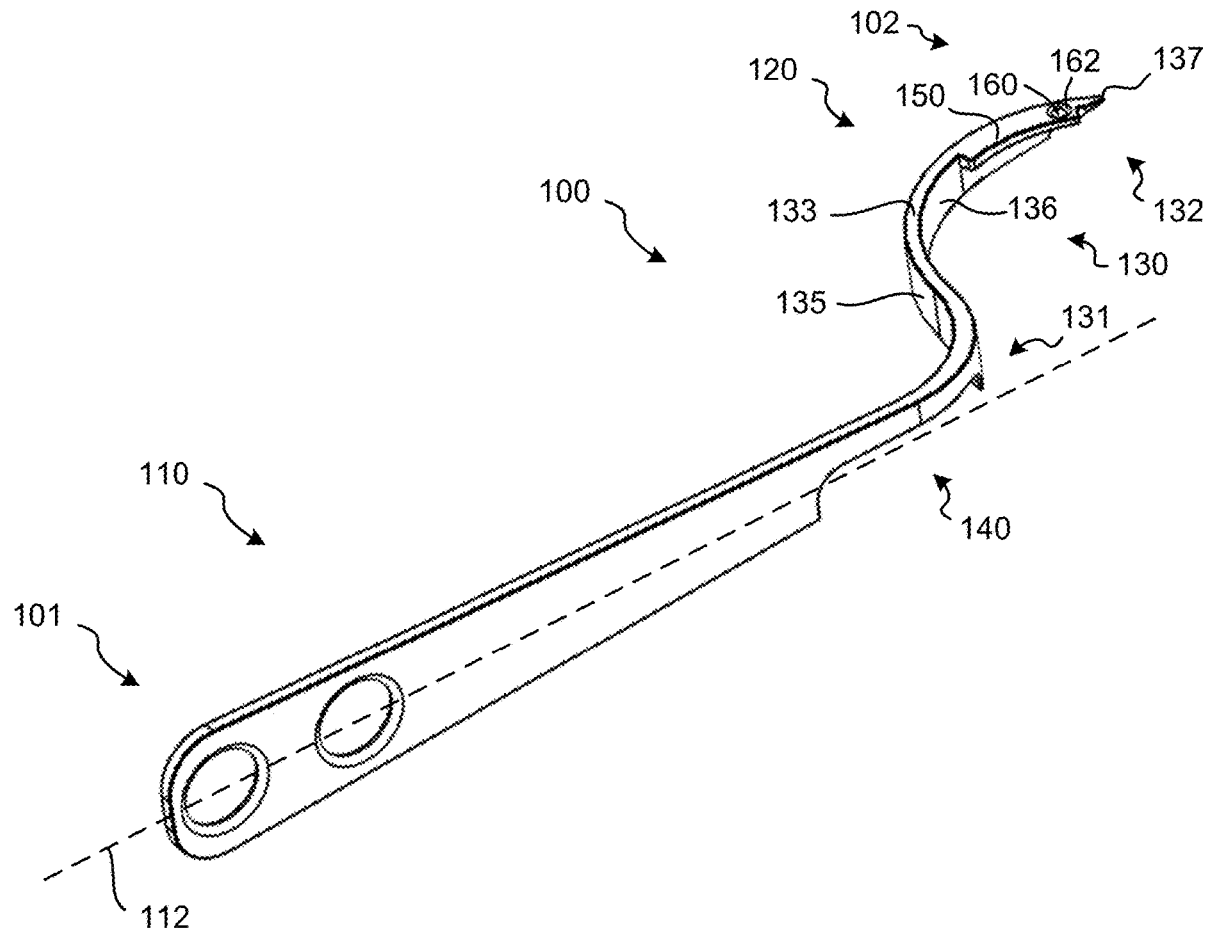

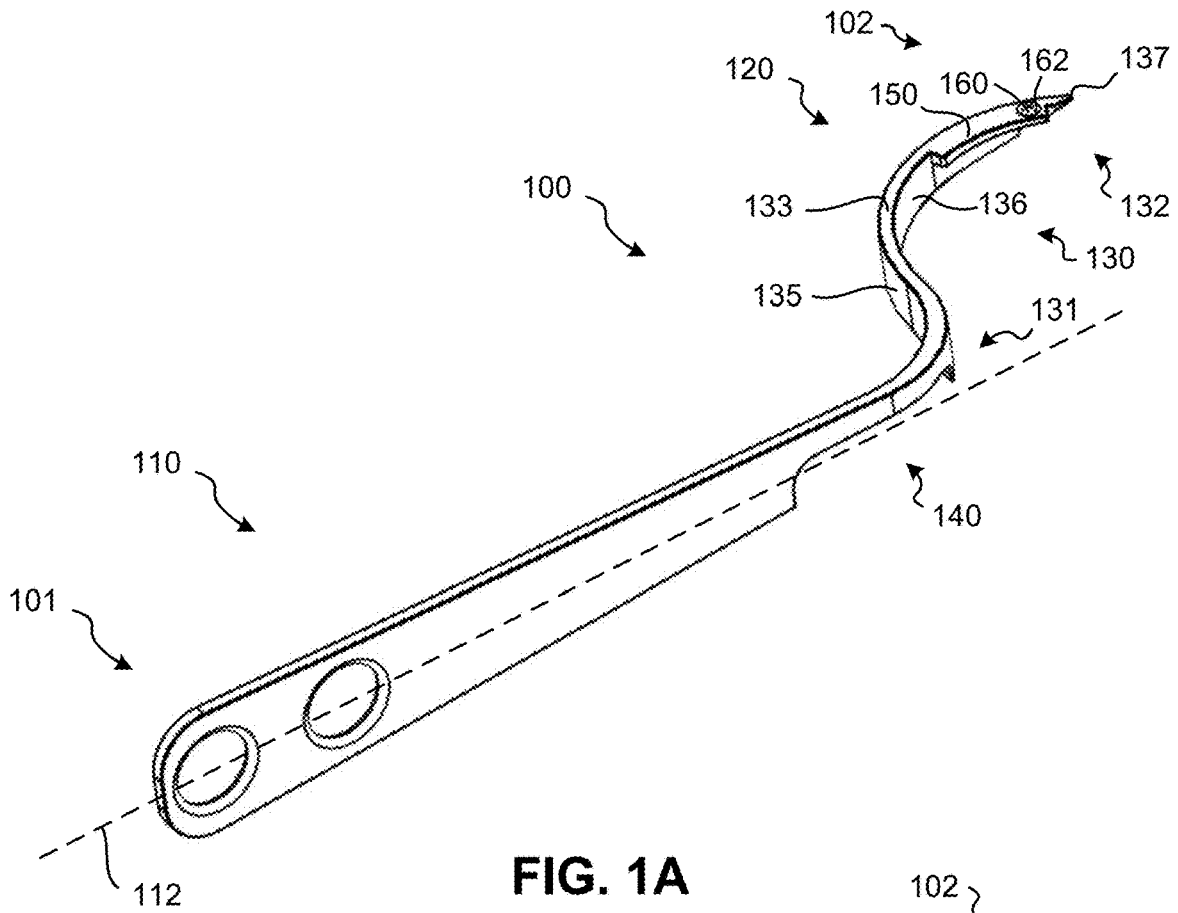

FIG. 1A

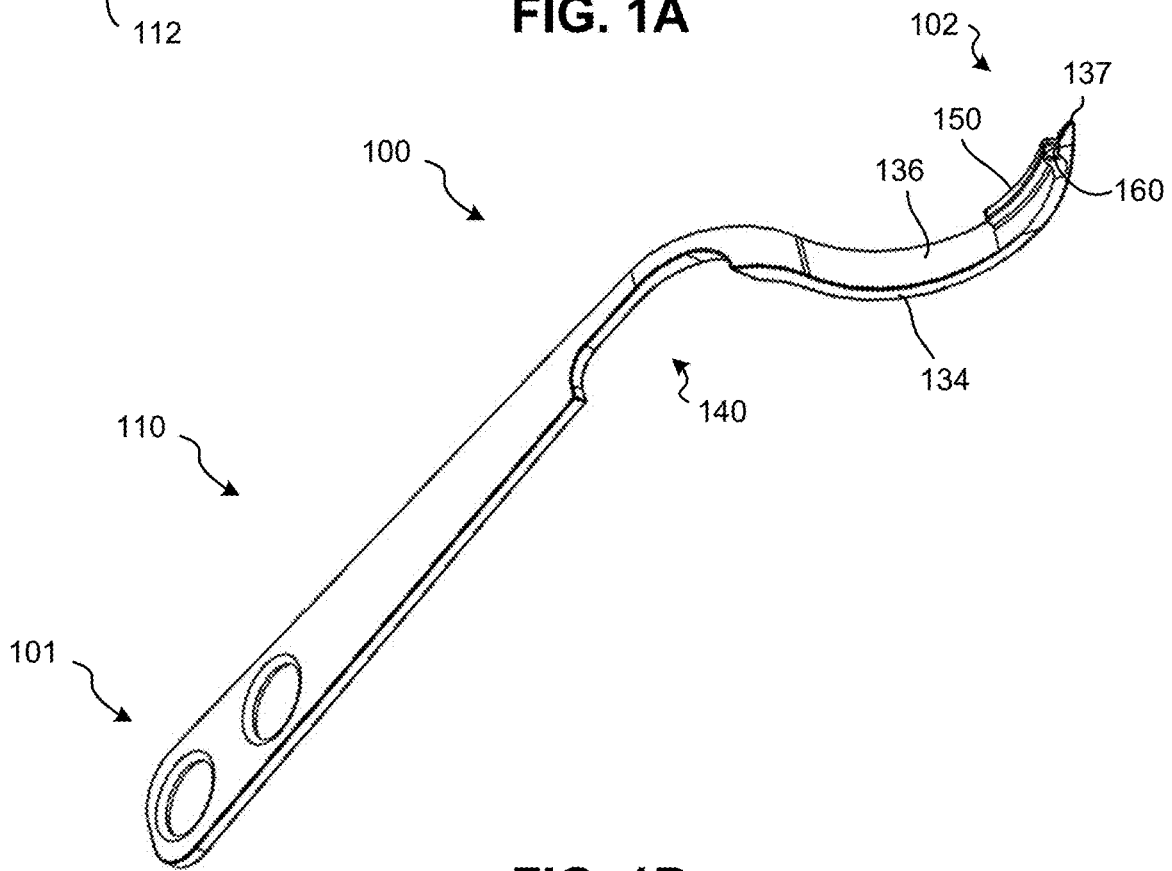

FIG. 1B

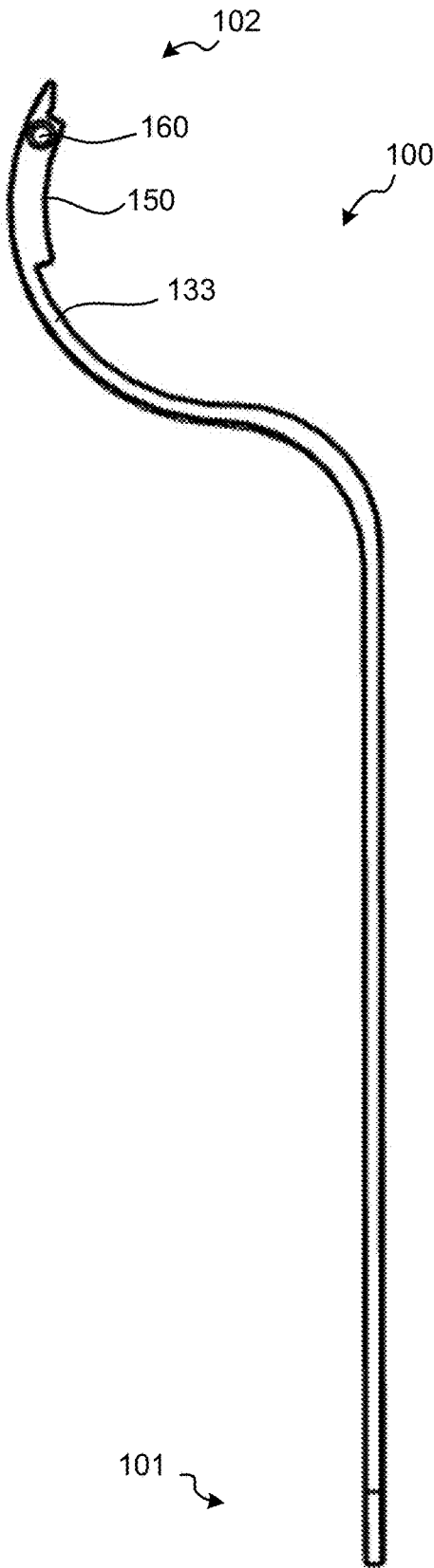

FIG. 1C

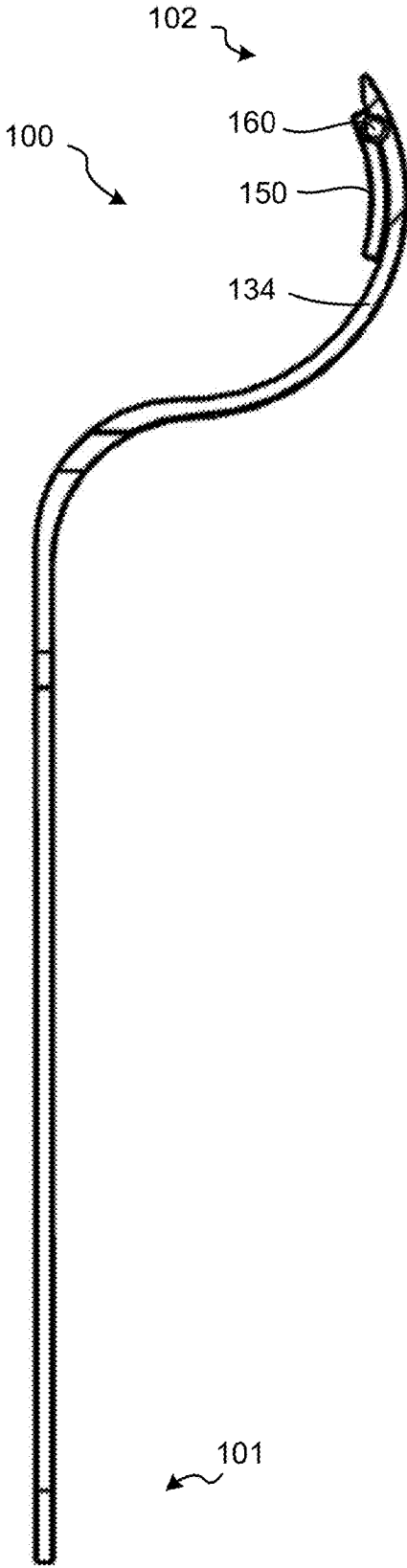

FIG. 1D

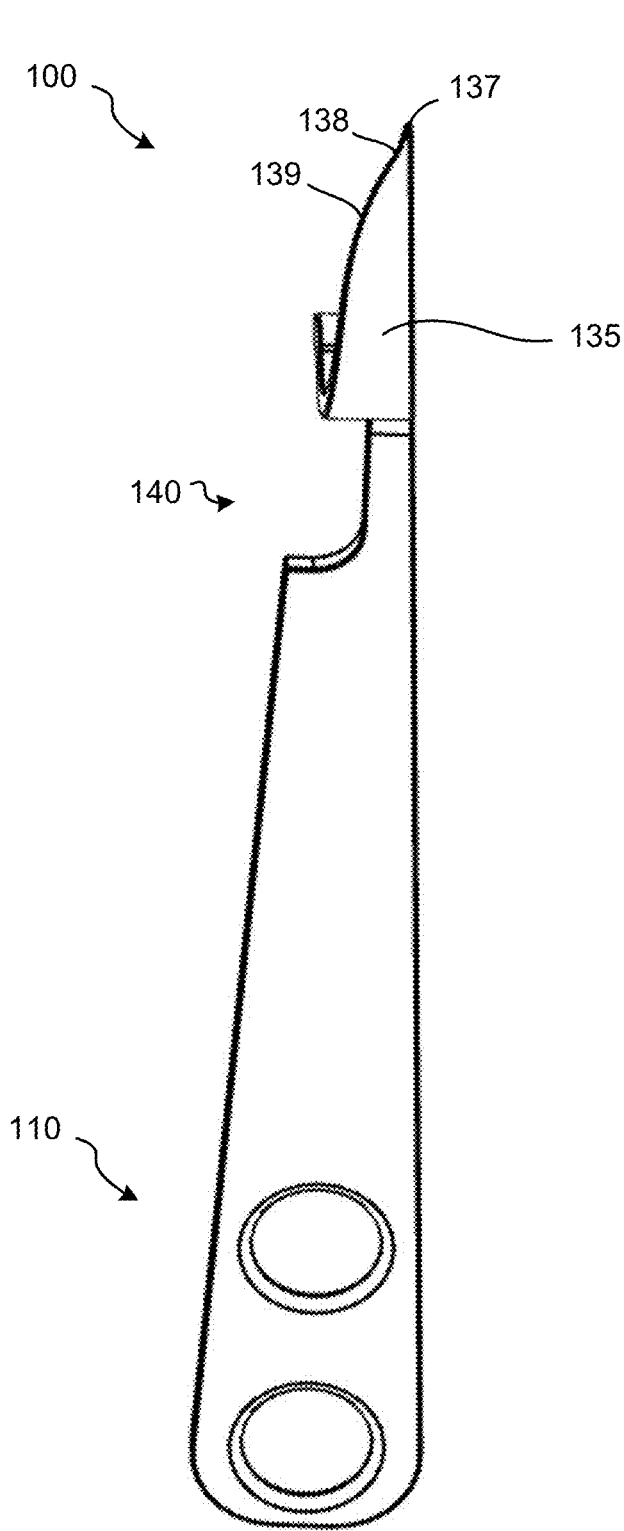

FIG. 1E

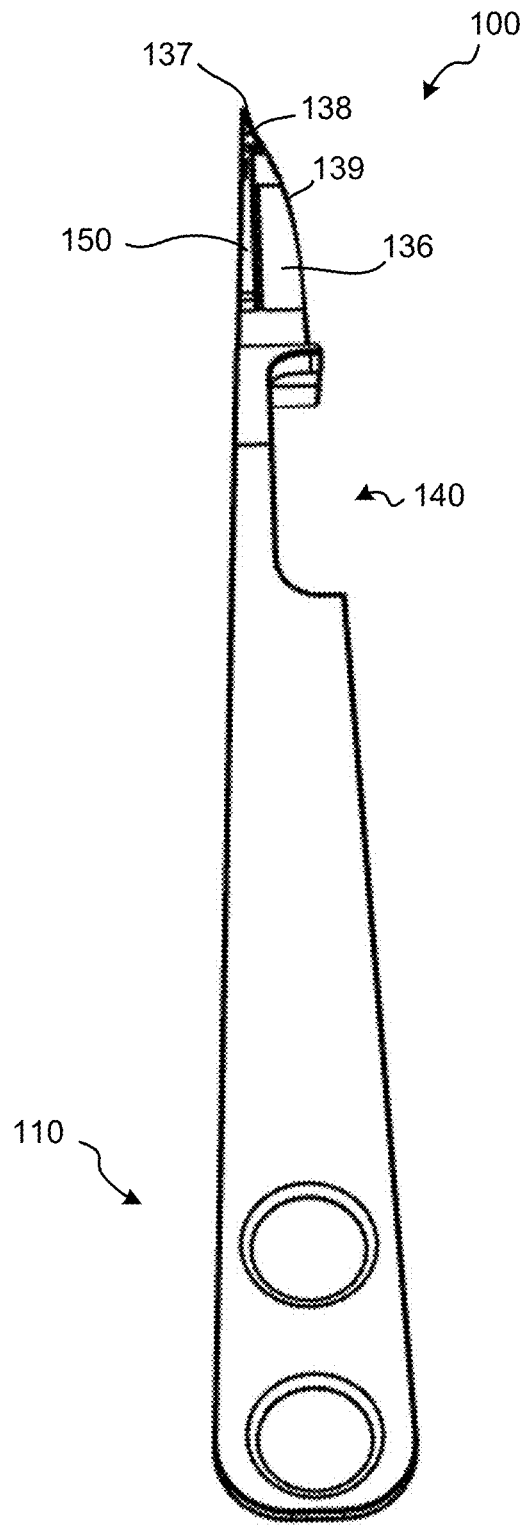
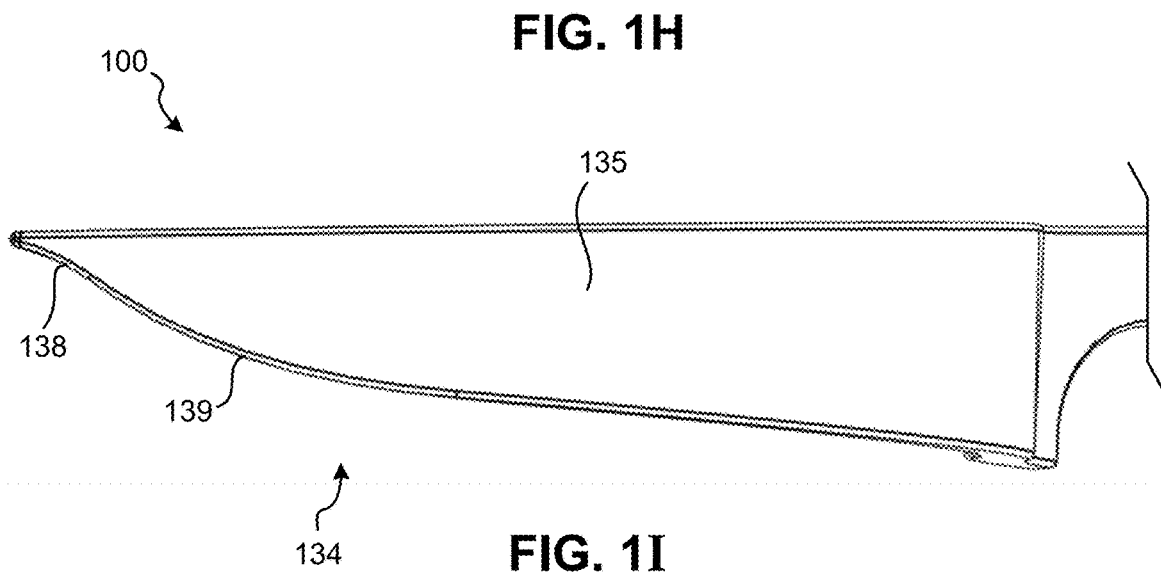
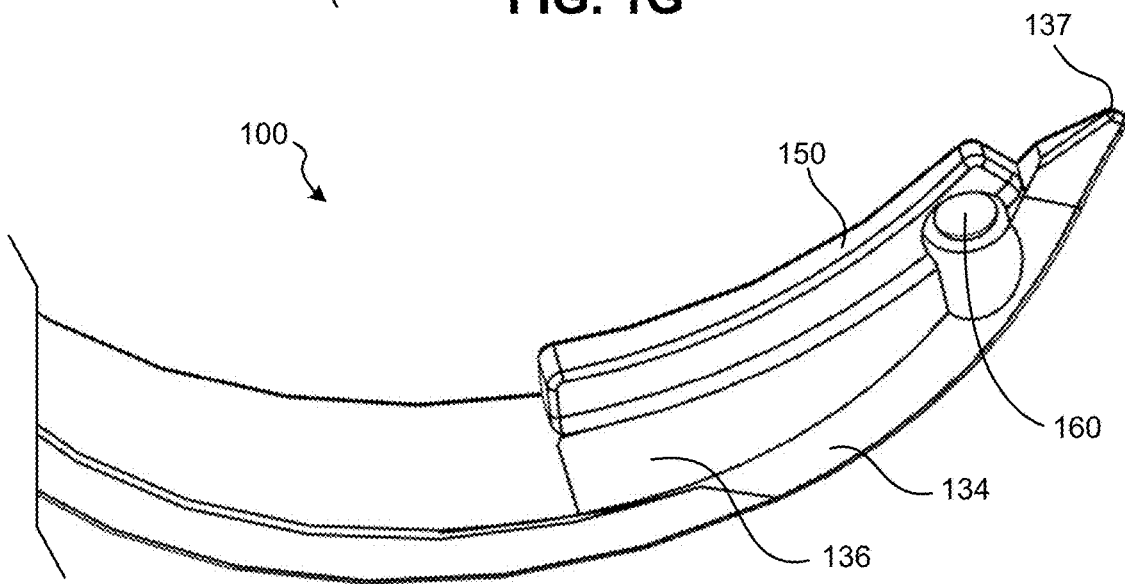
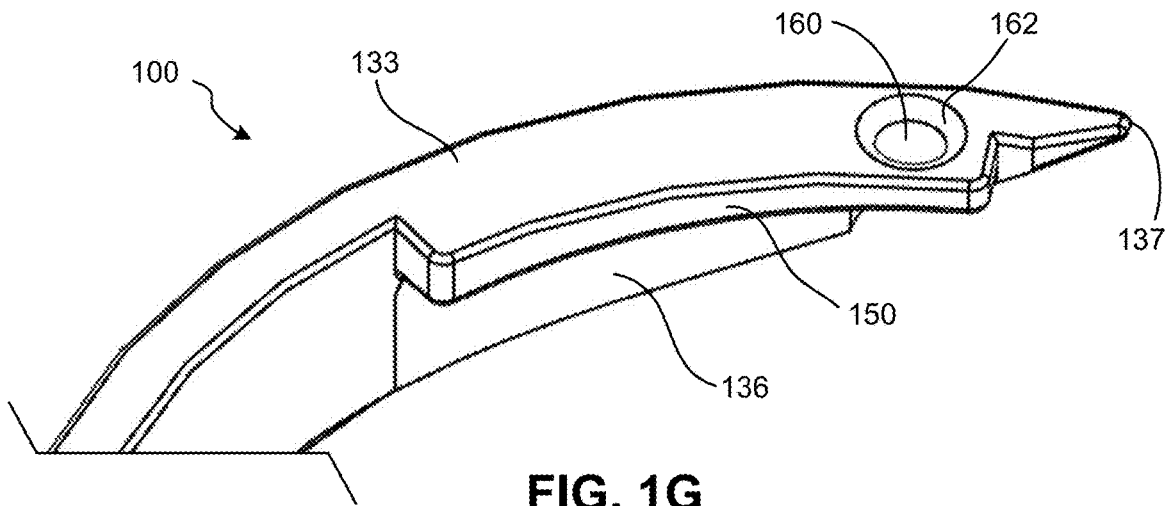

FIG. 1F



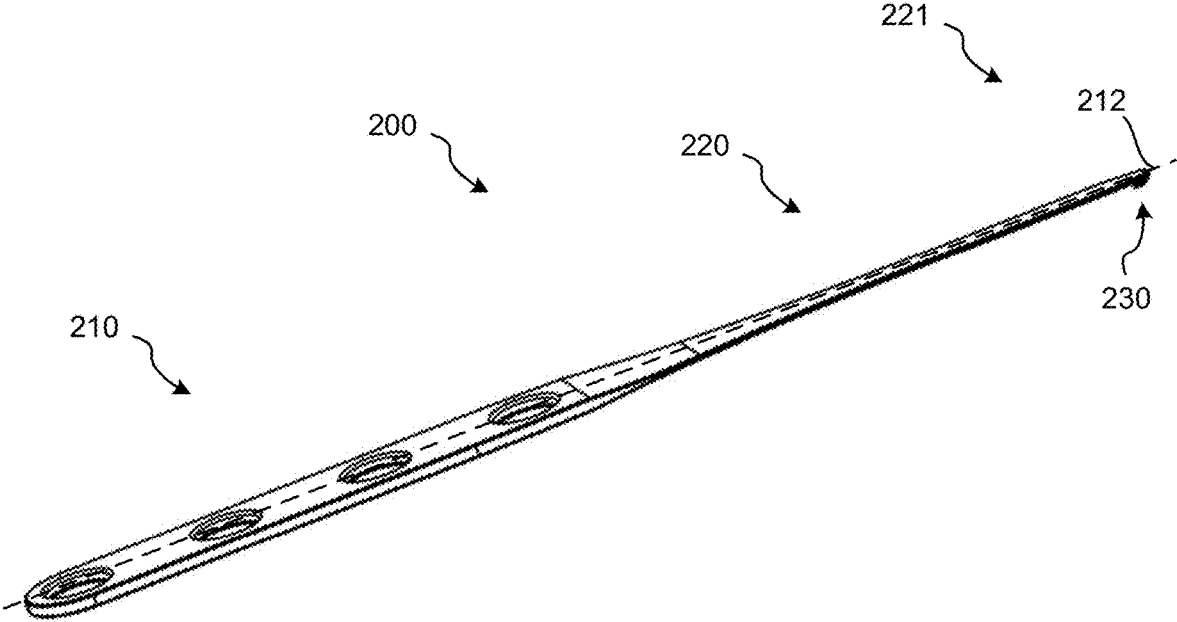

FIG. 2A

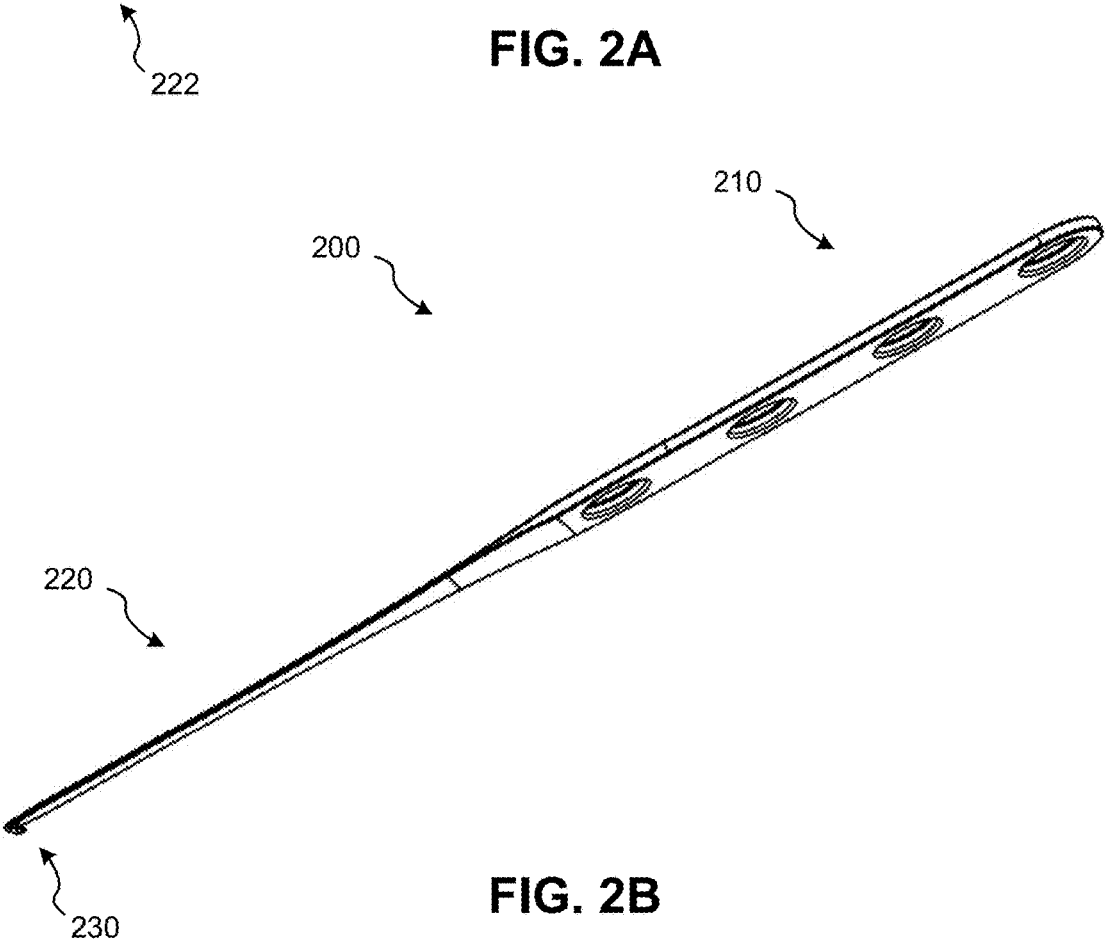

FIG. 2B

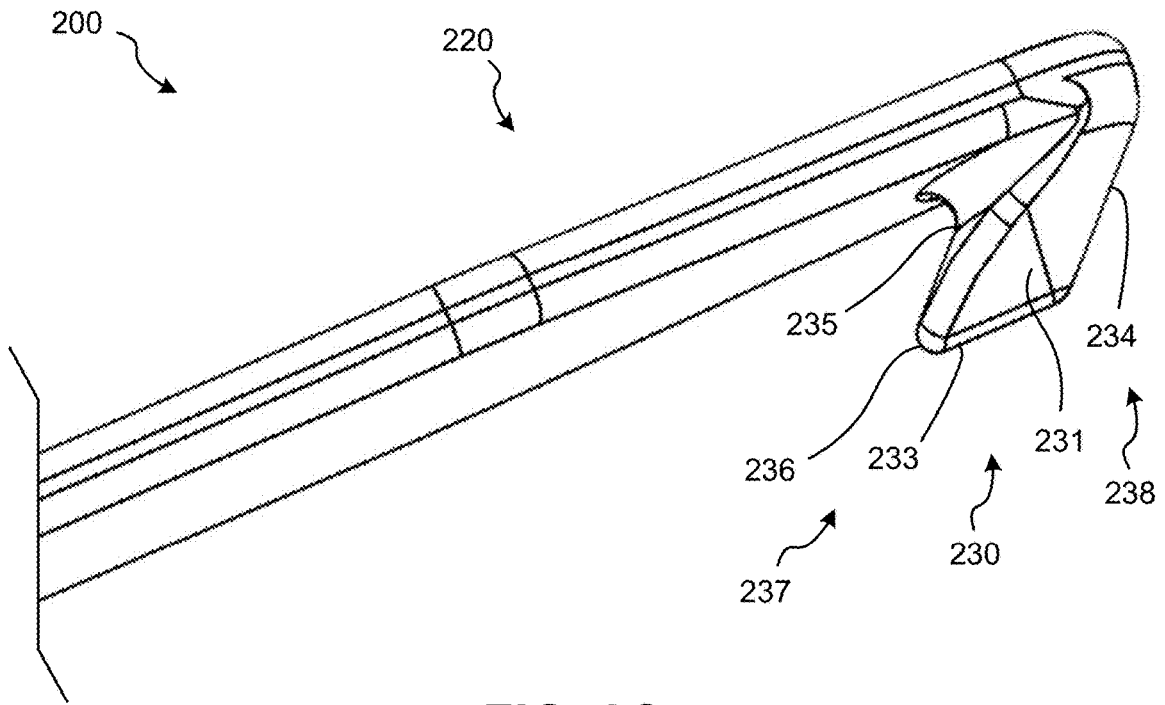

FIG. 2C

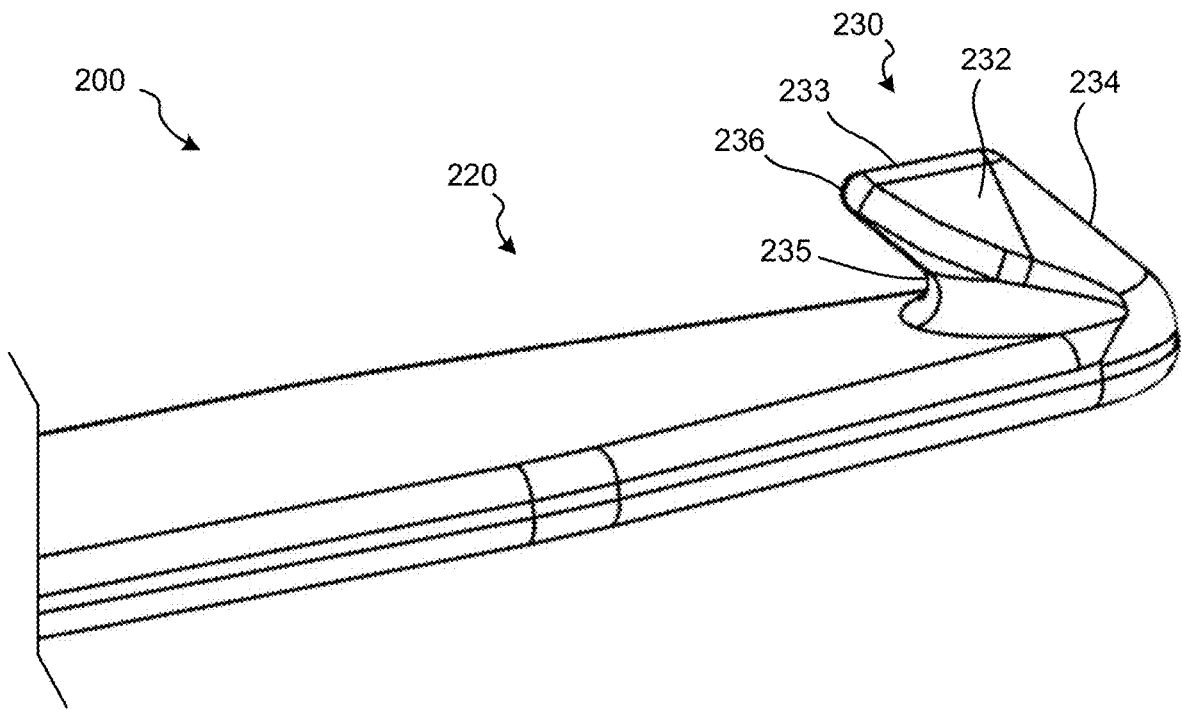

FIG. 2D

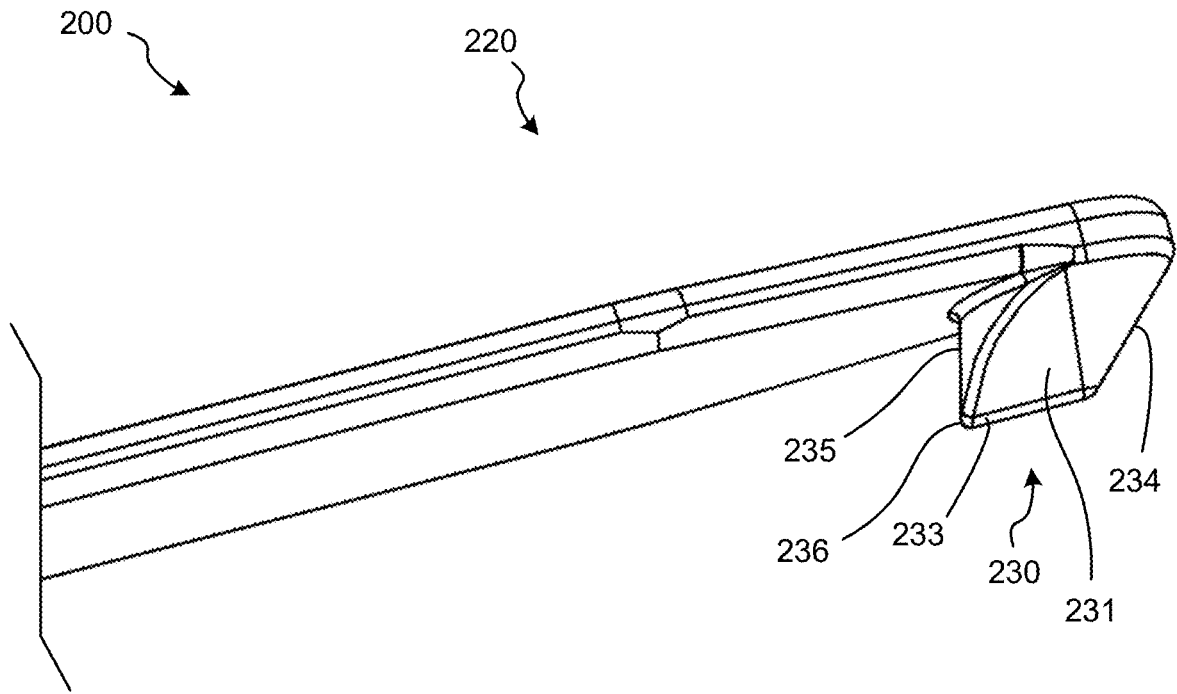

FIG. 2E

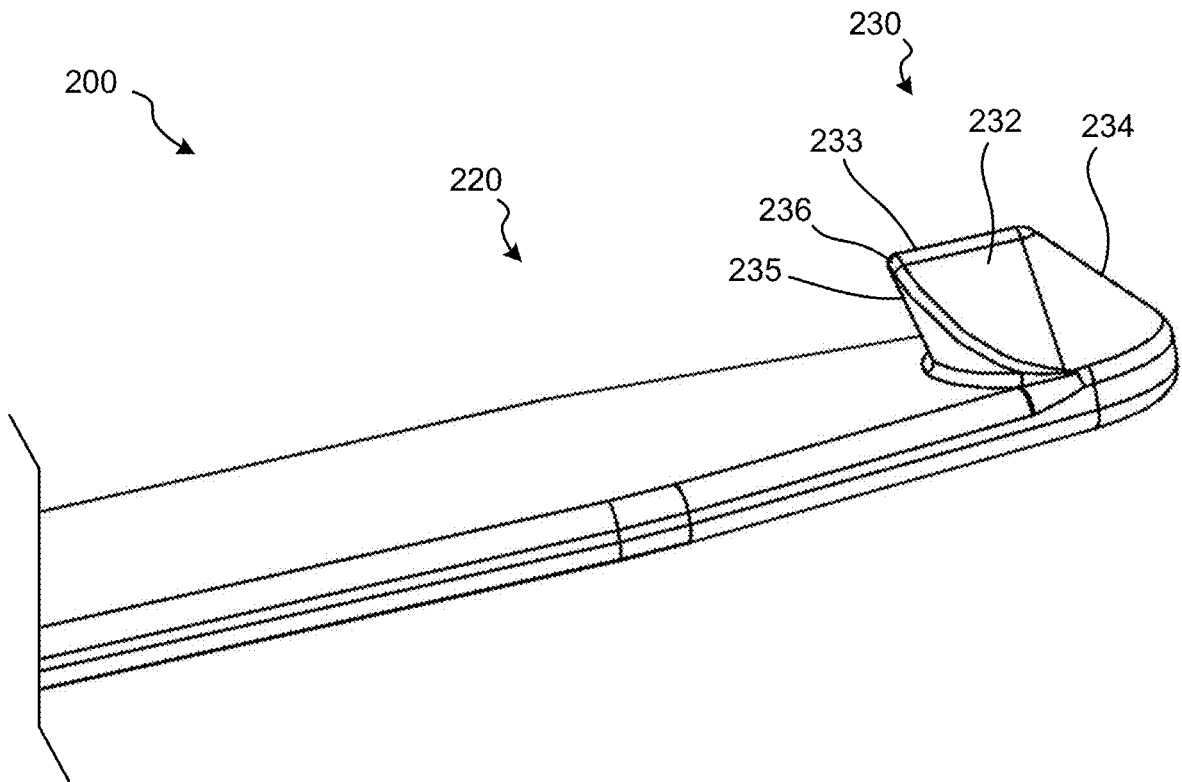
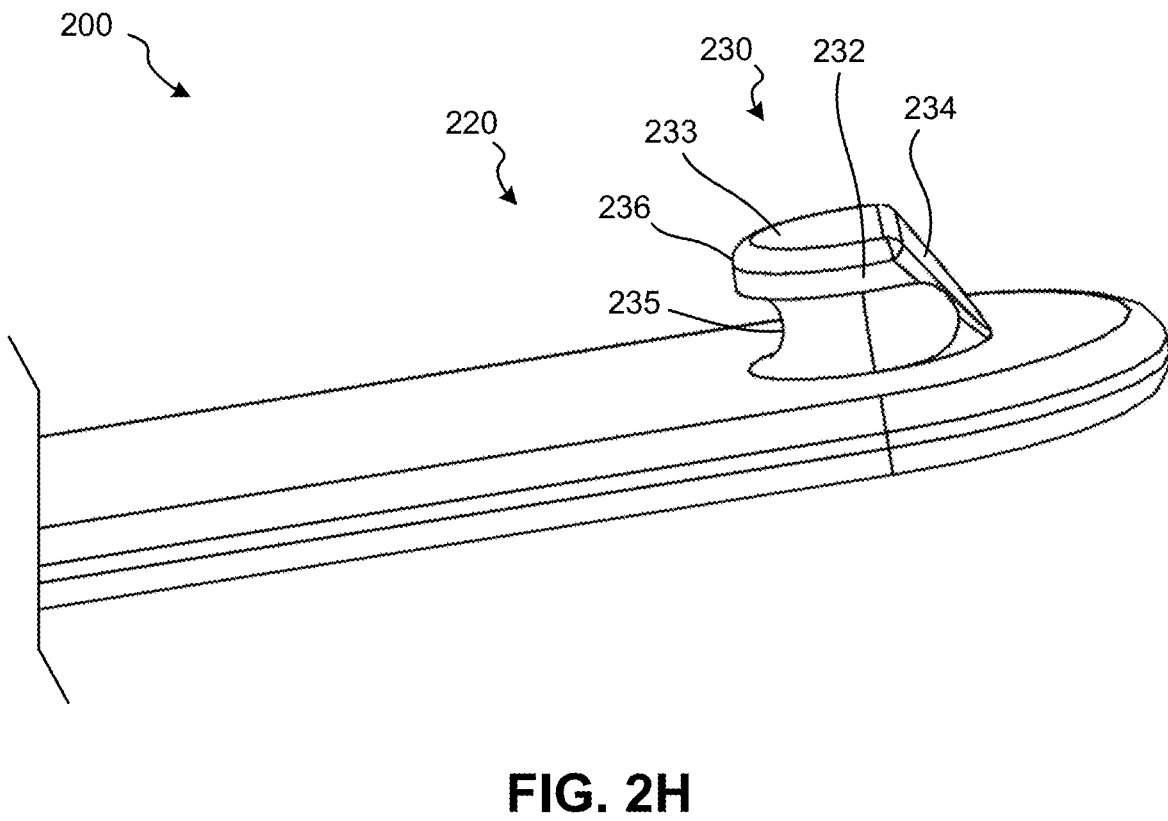
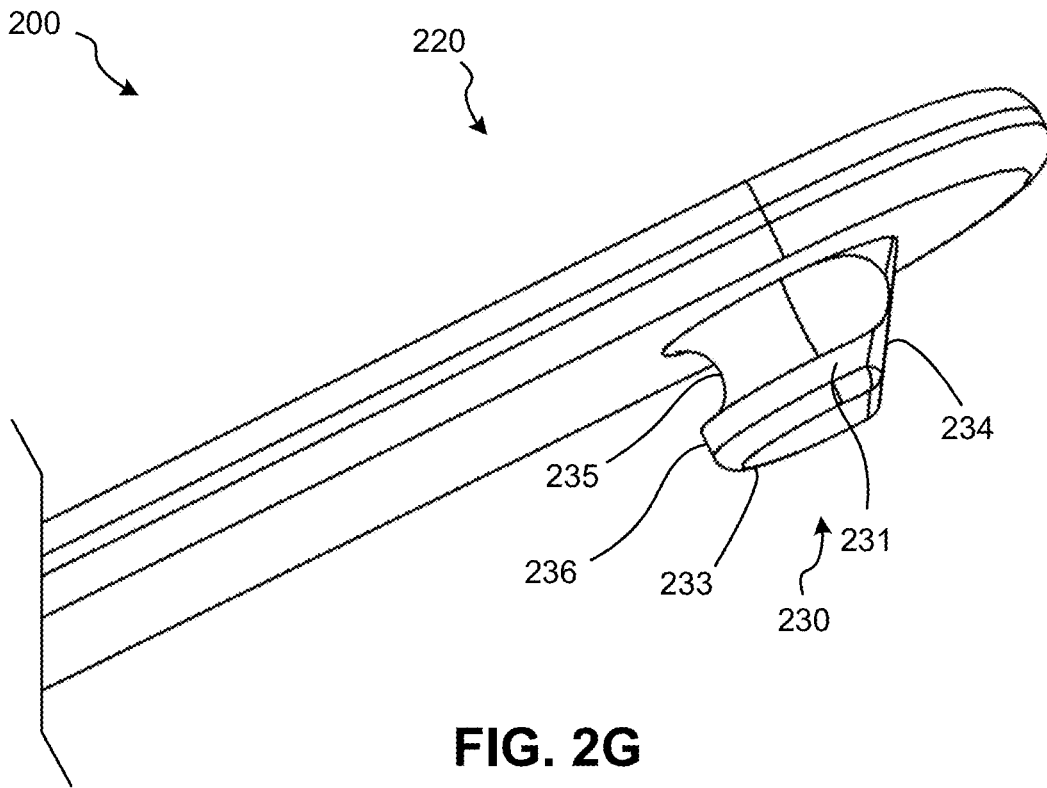

FIG. 2F



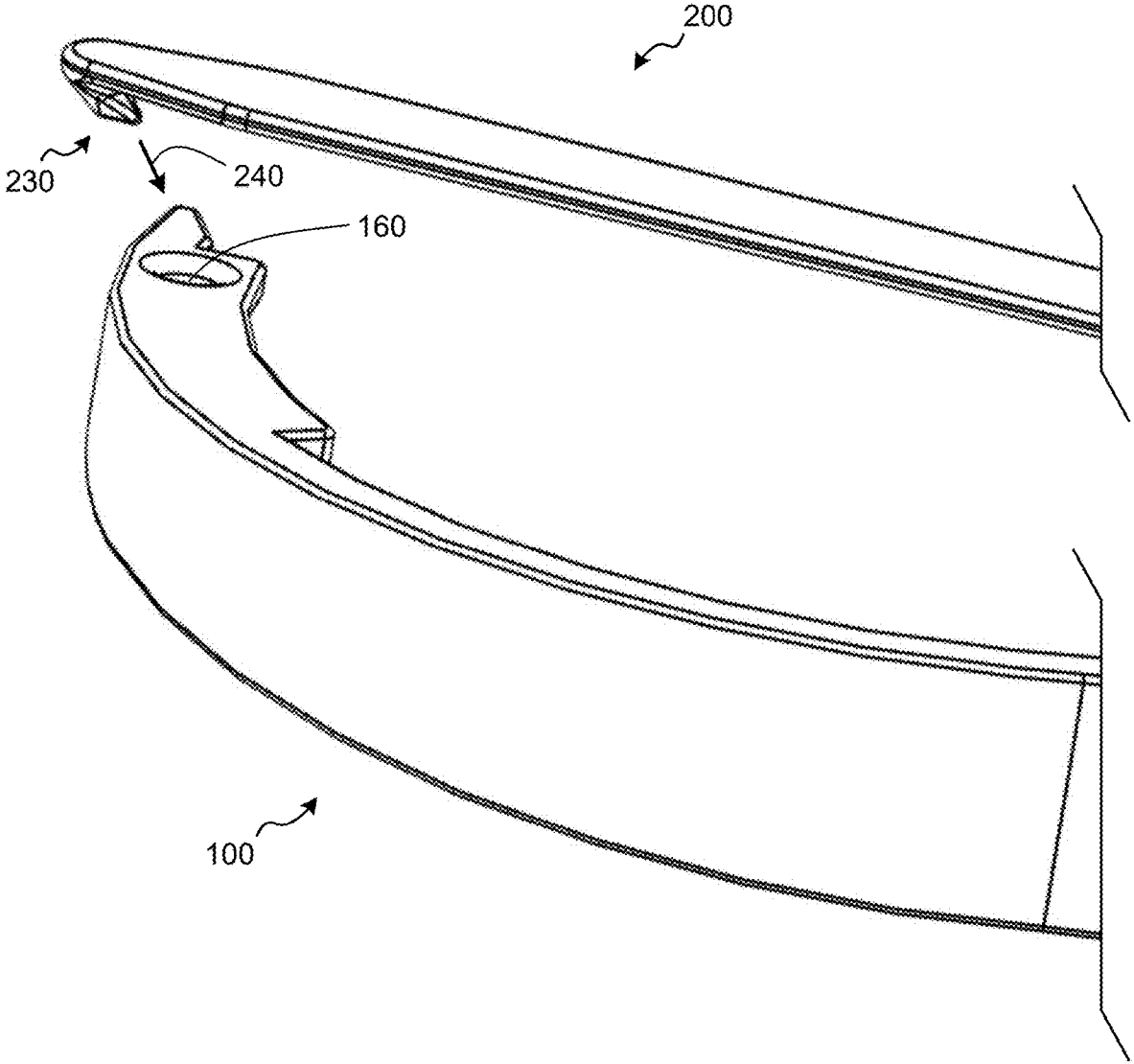

FIG. 3

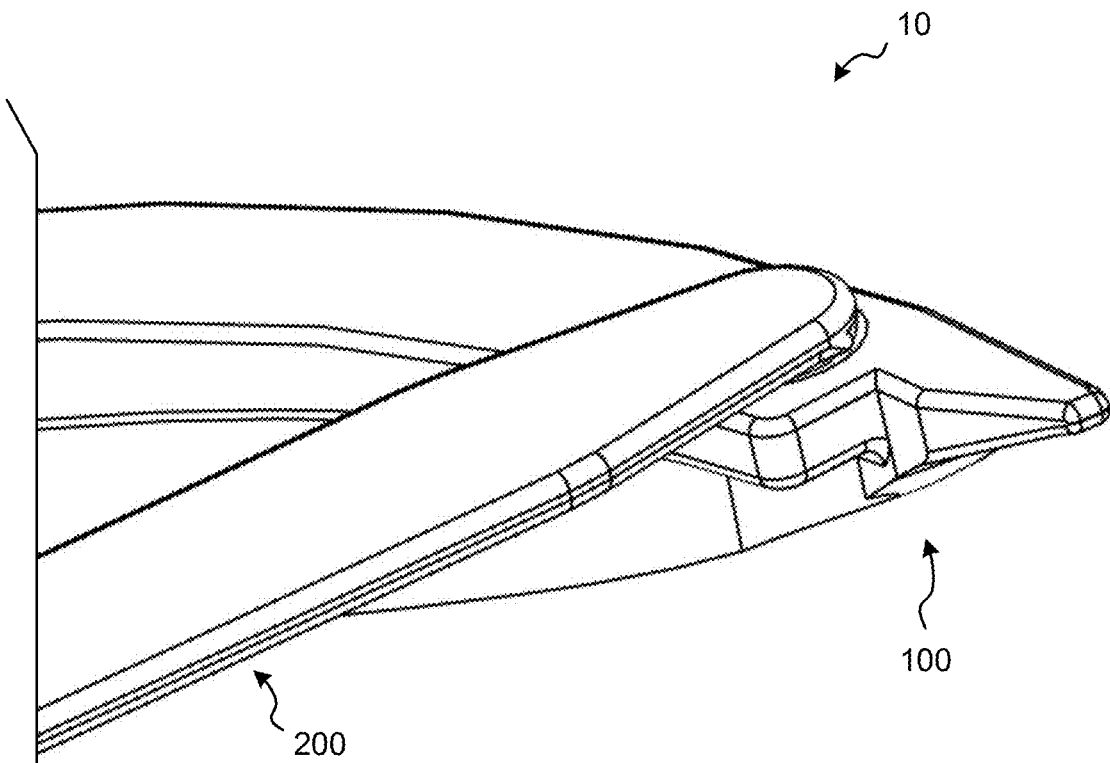

FIG. 4

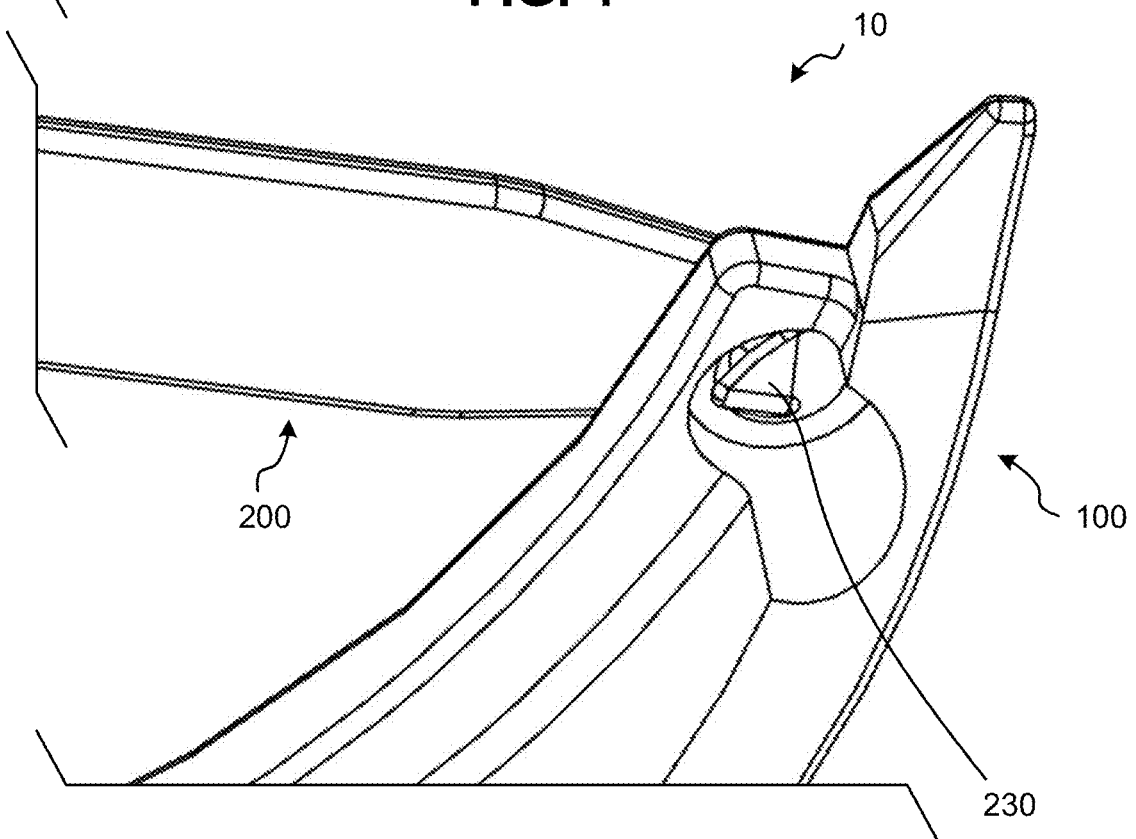

FIG. 5

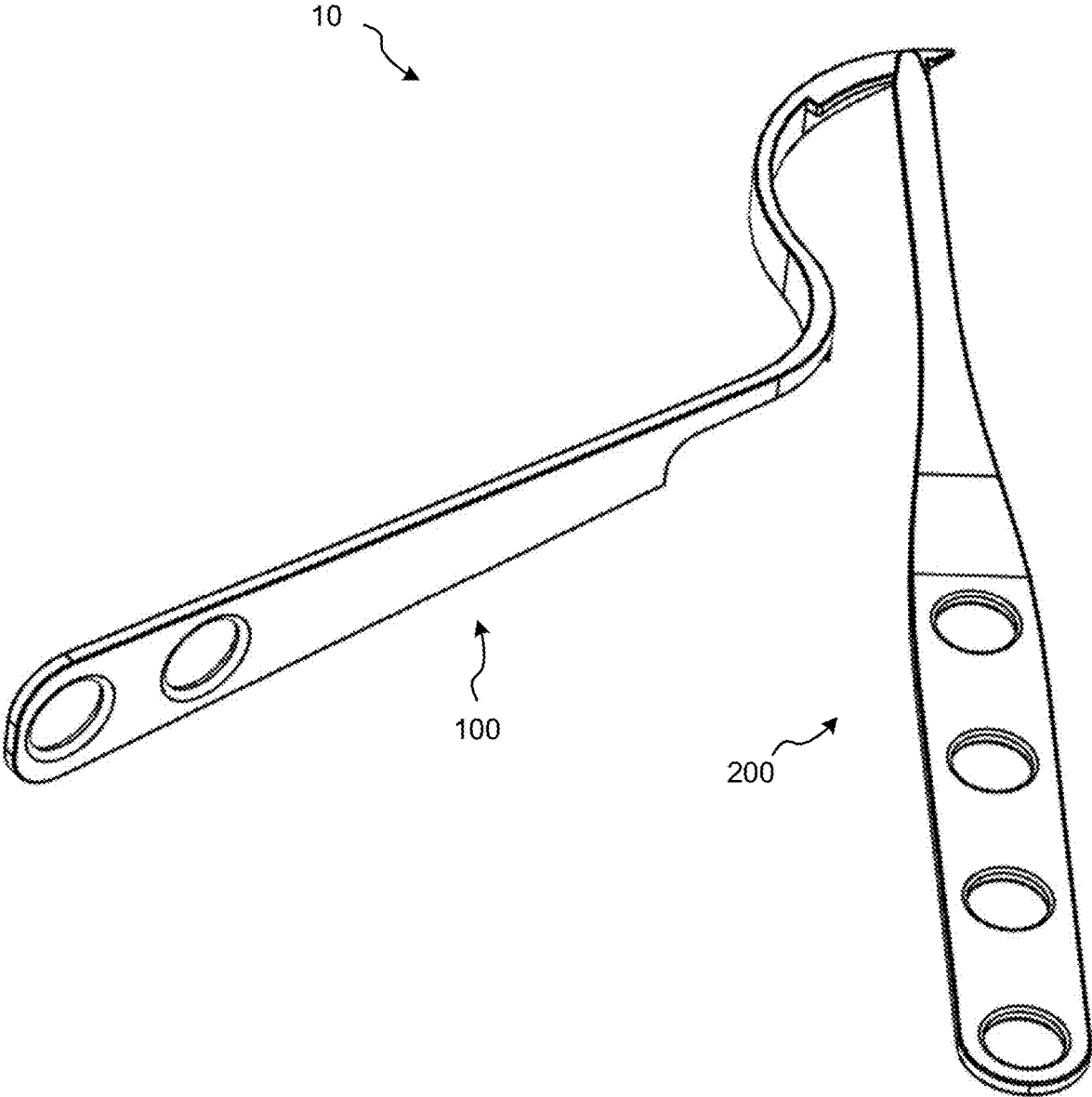

FIG. 6

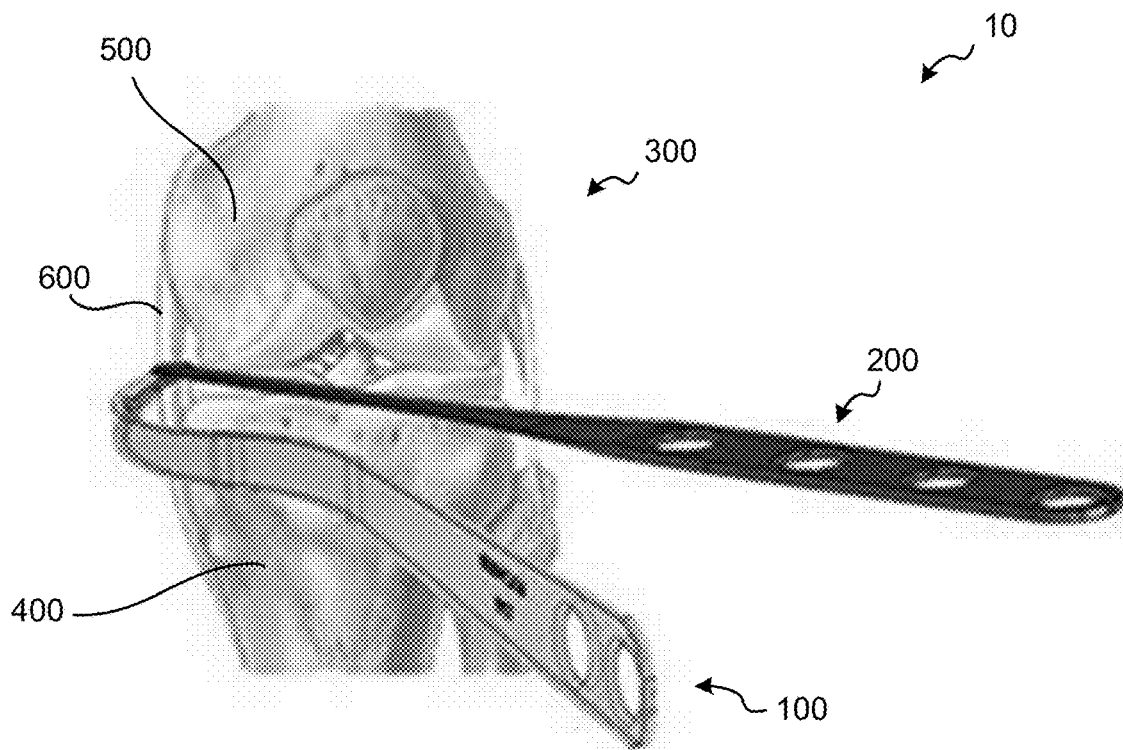

FIG. 7

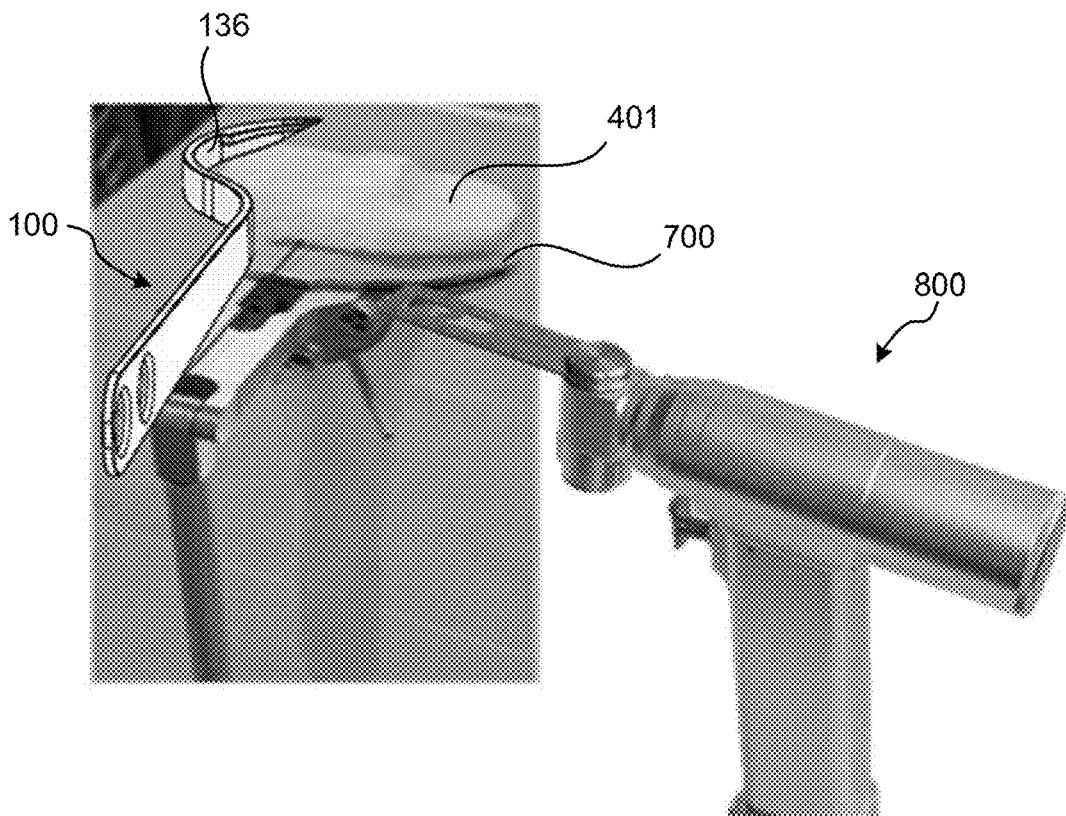

FIG. 8

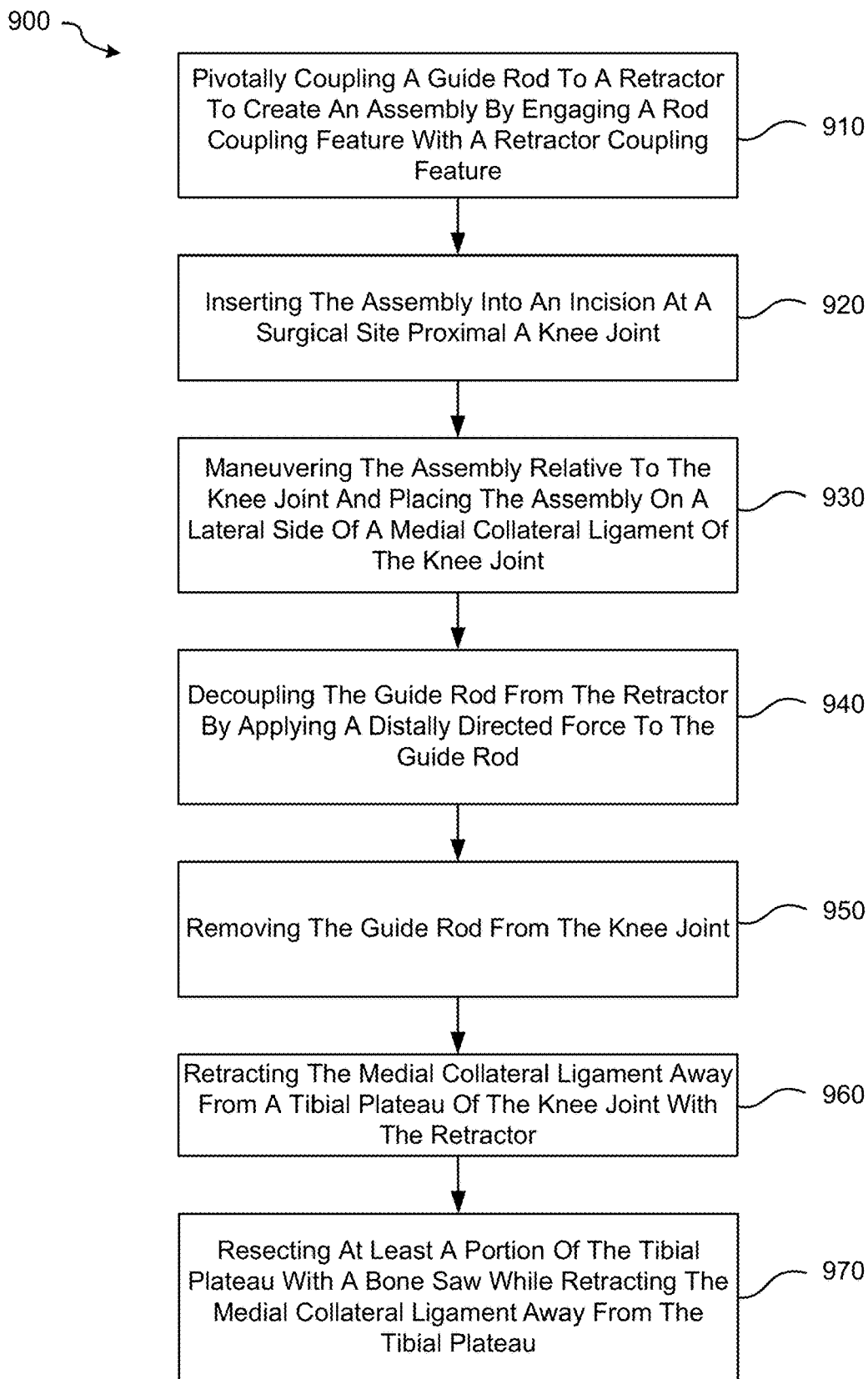

FIG. 9

1000

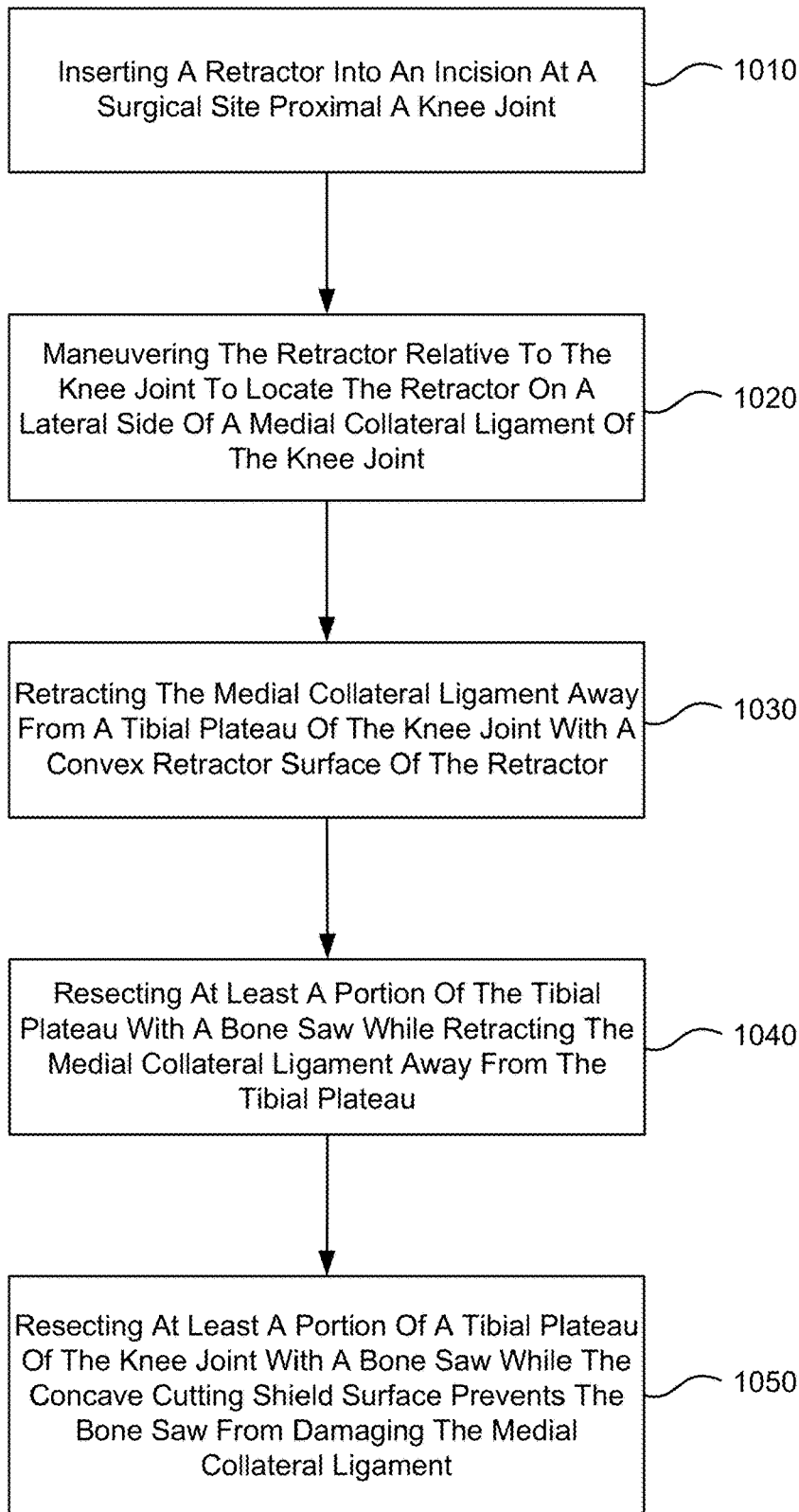

FIG. 10

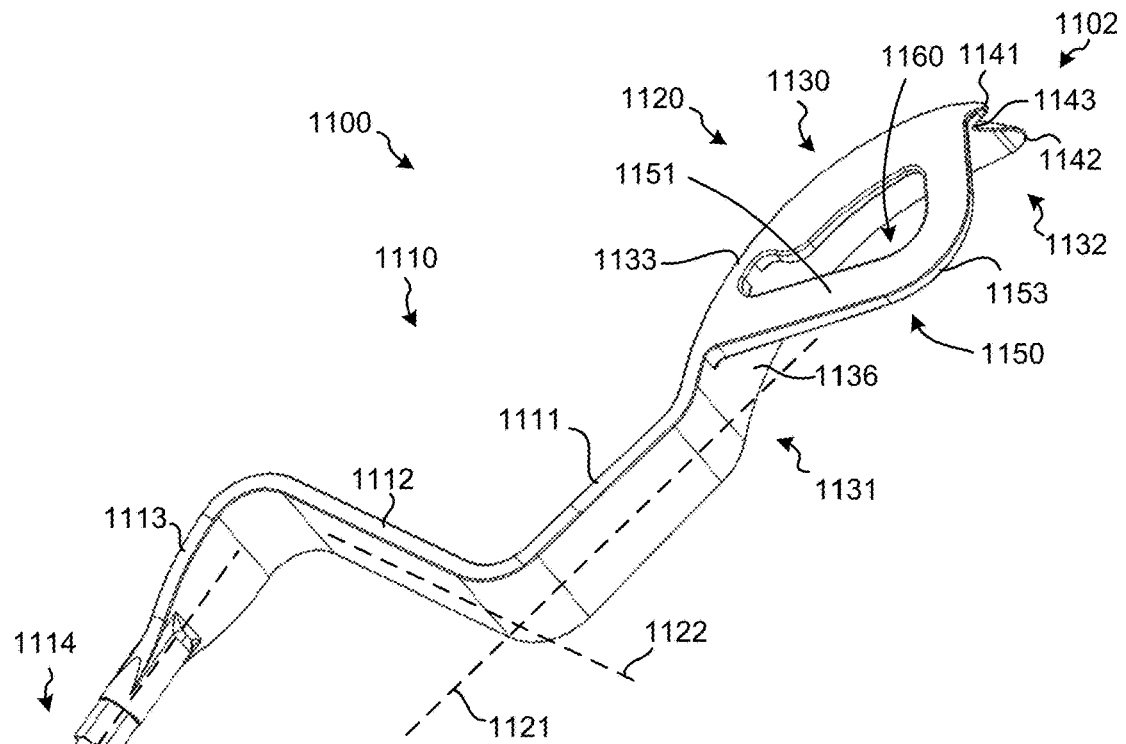

FIG. 11A

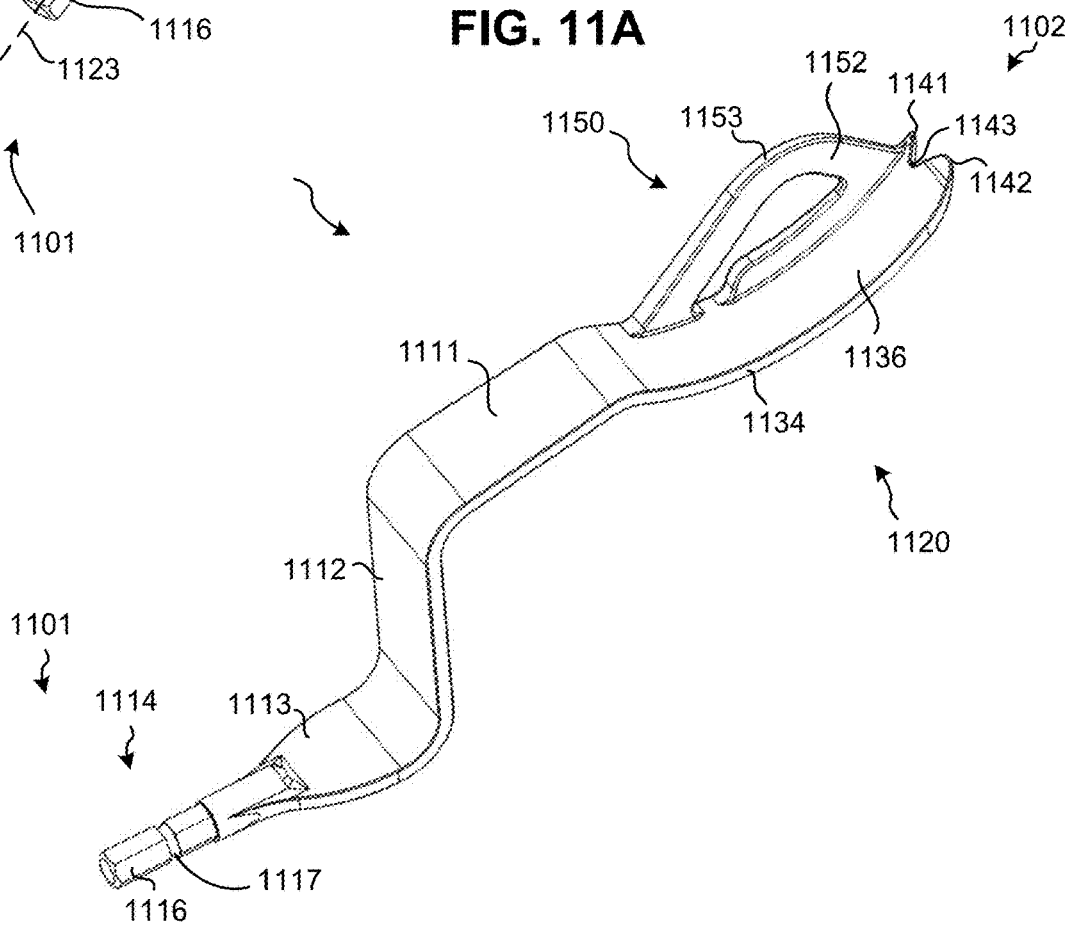

FIG. 11B

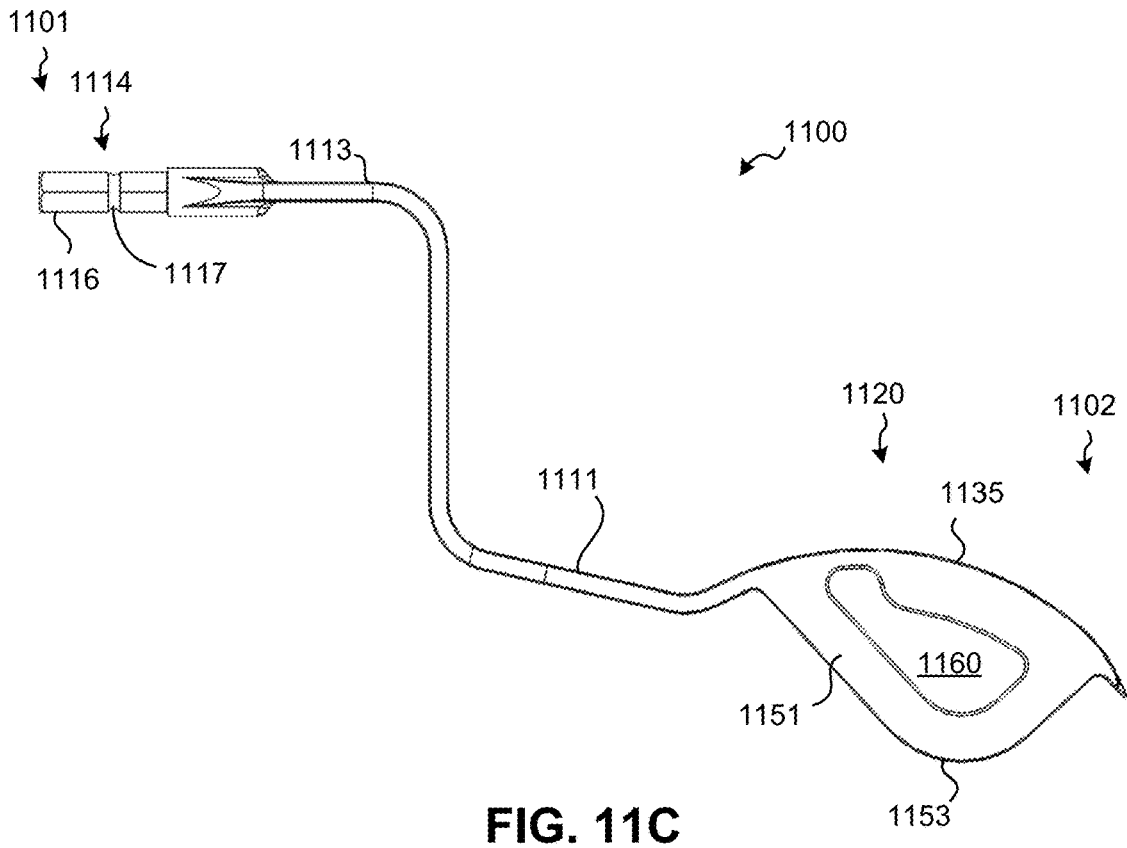

FIG. 11C

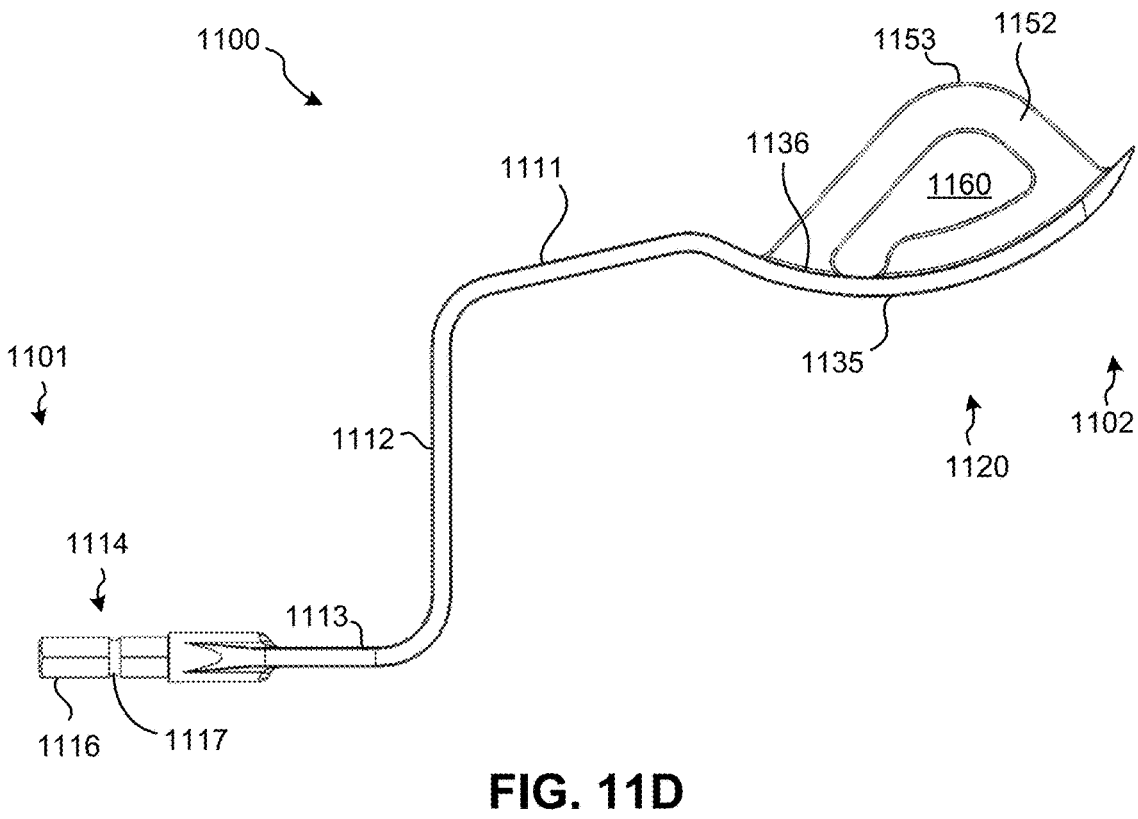

FIG. 11D

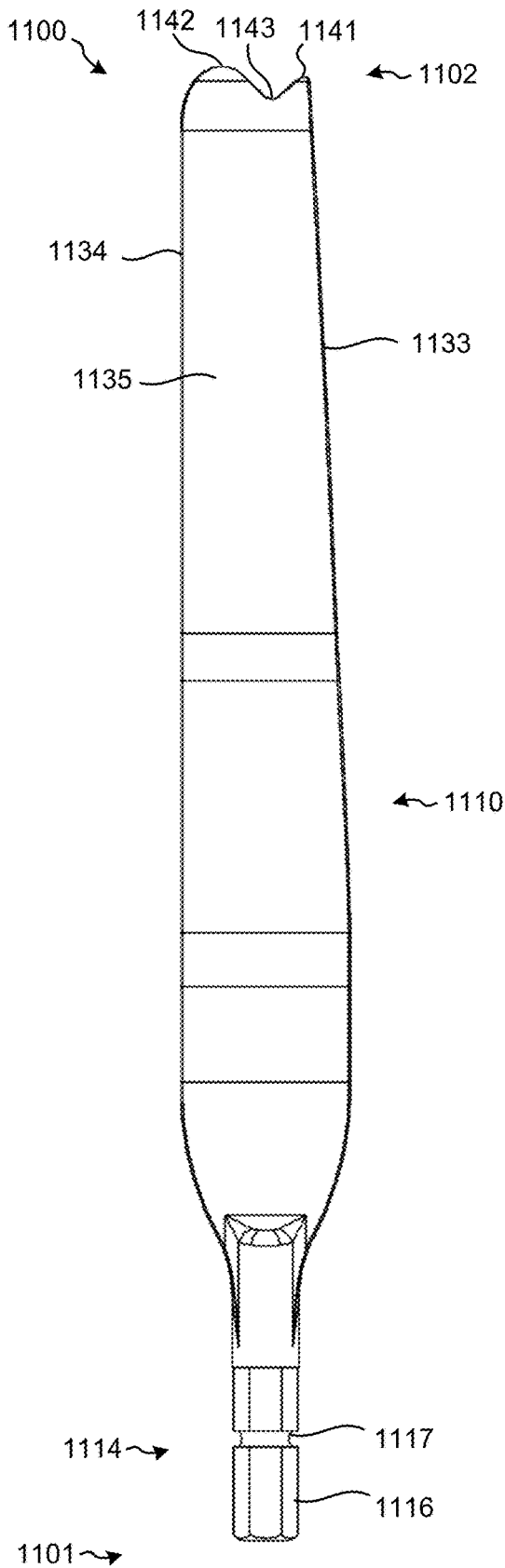

FIG. 11E

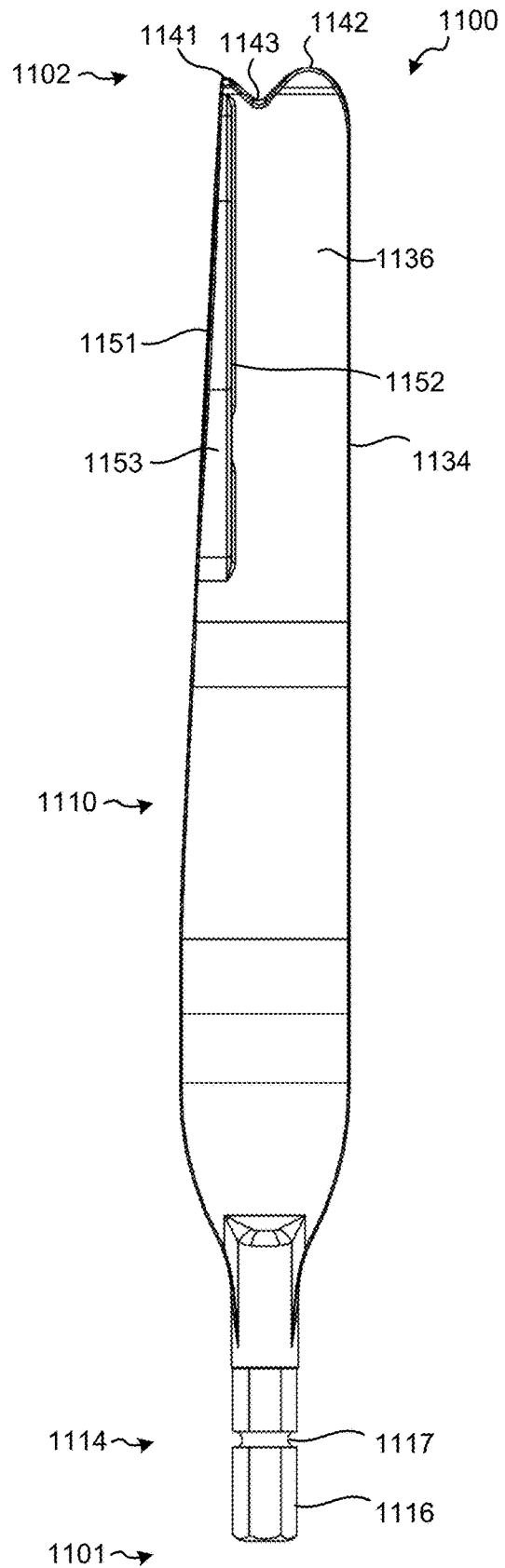

FIG. 11F

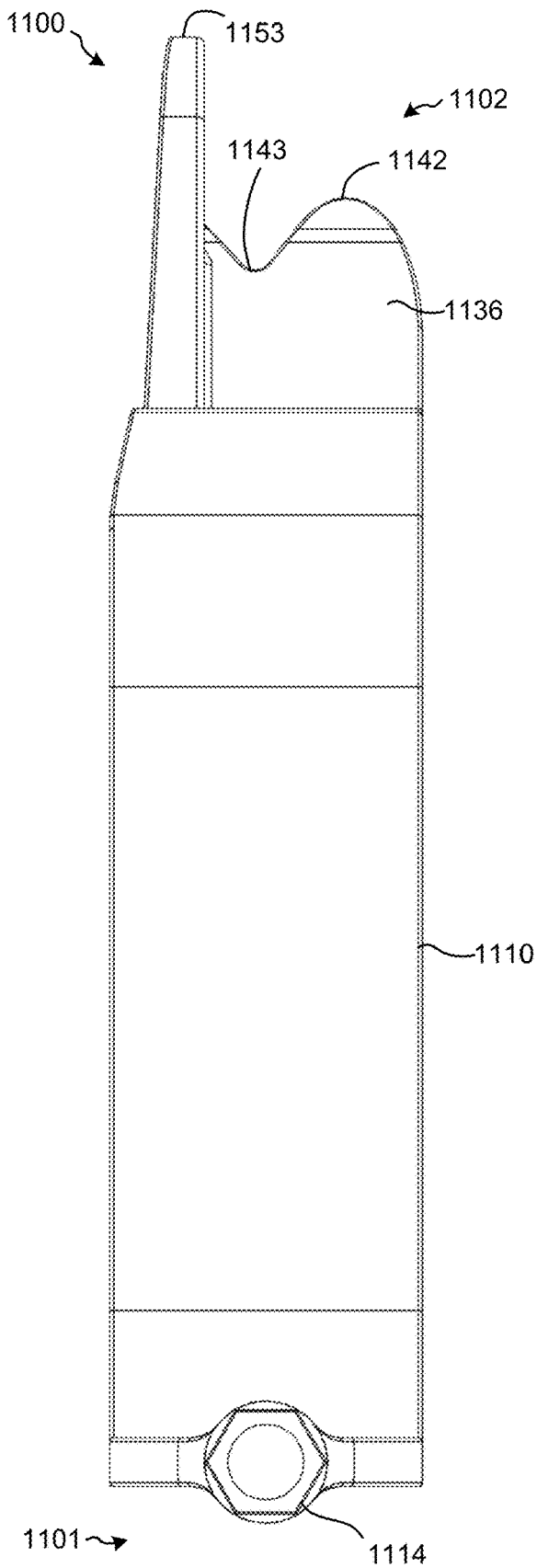

FIG. 11G

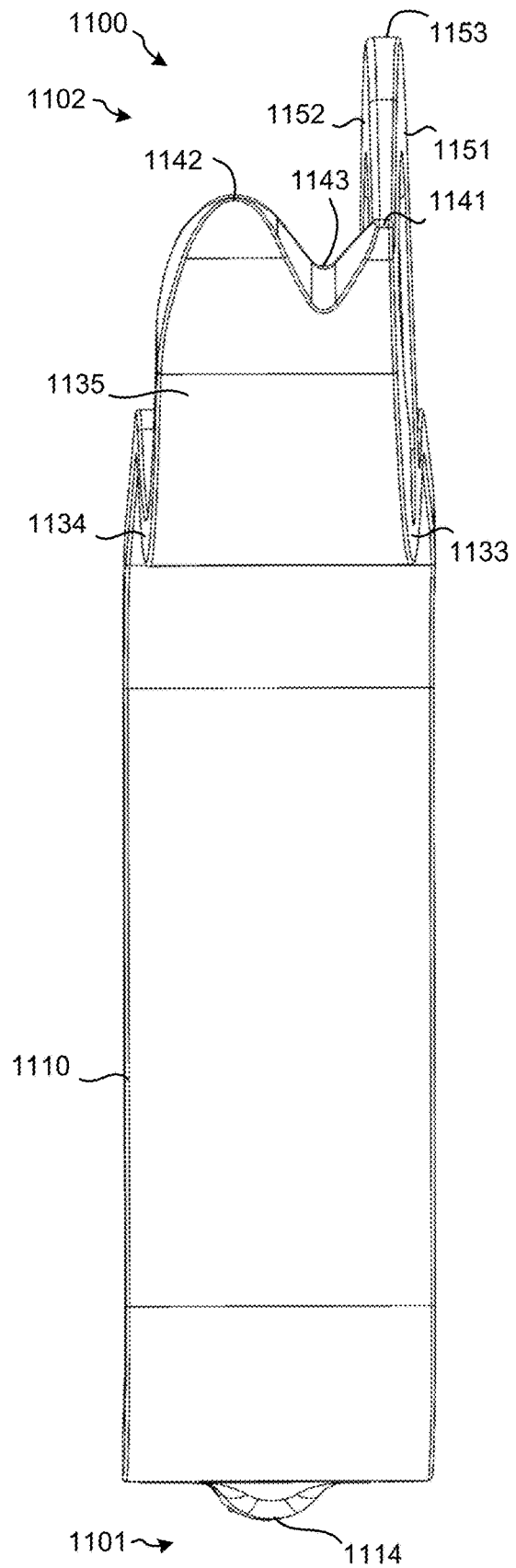

FIG. 11H

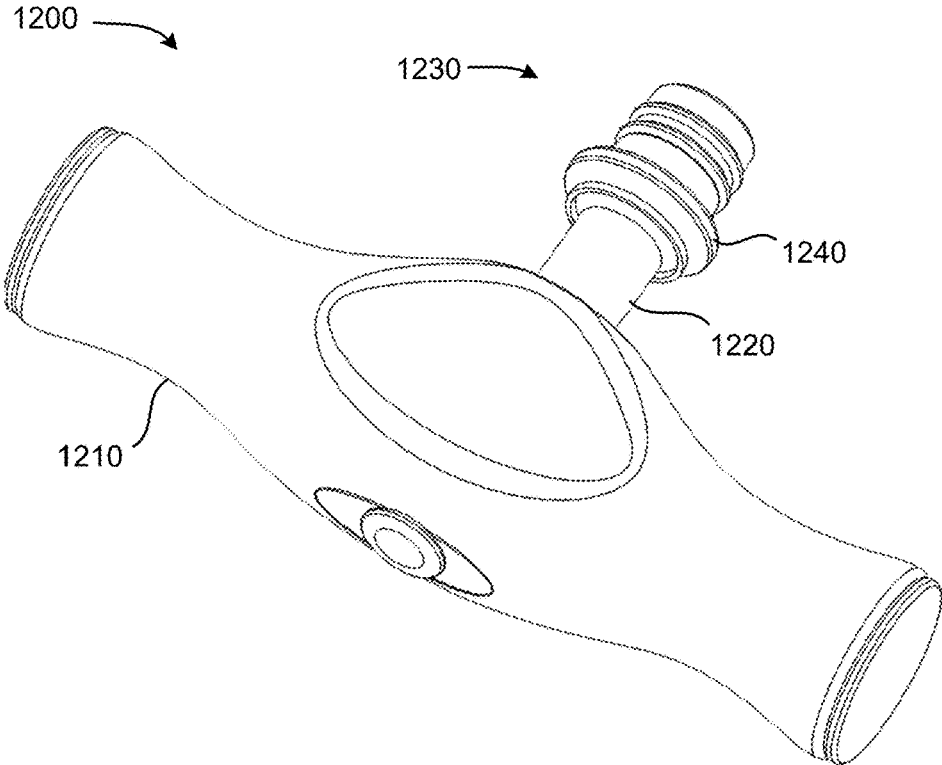

FIG. 12A

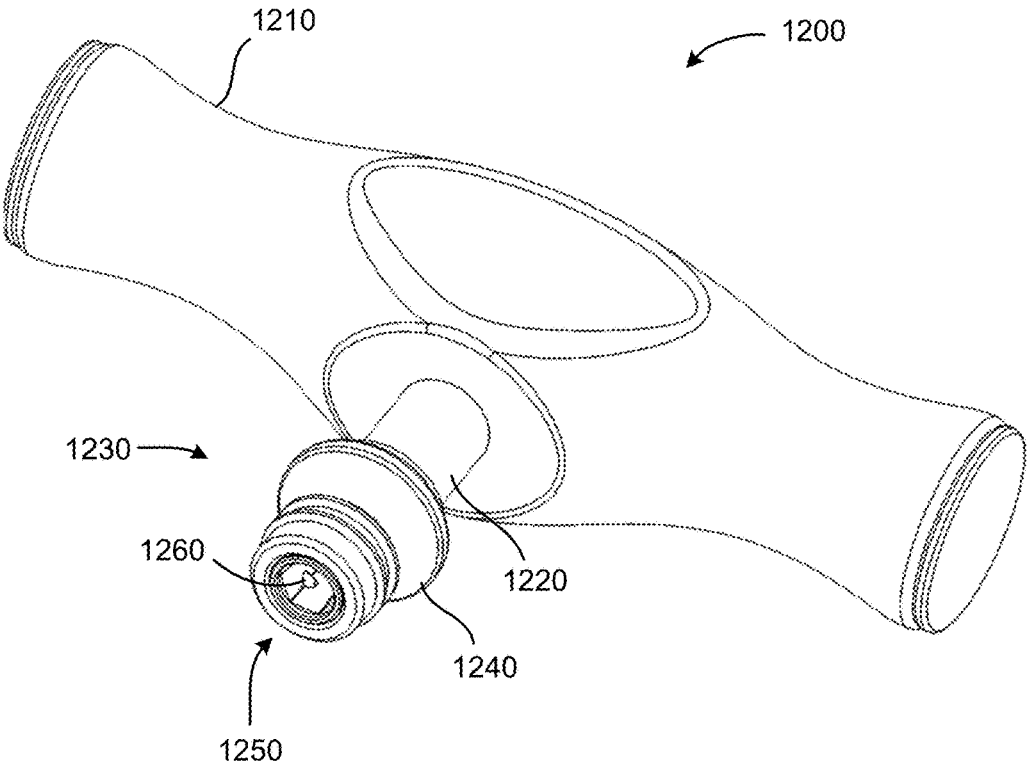

FIG. 12B

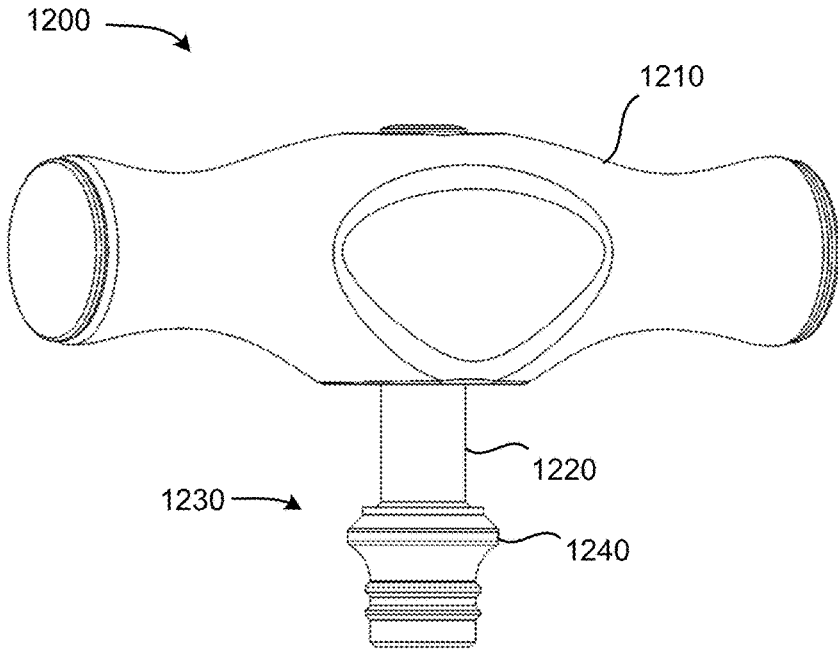

FIG. 12C

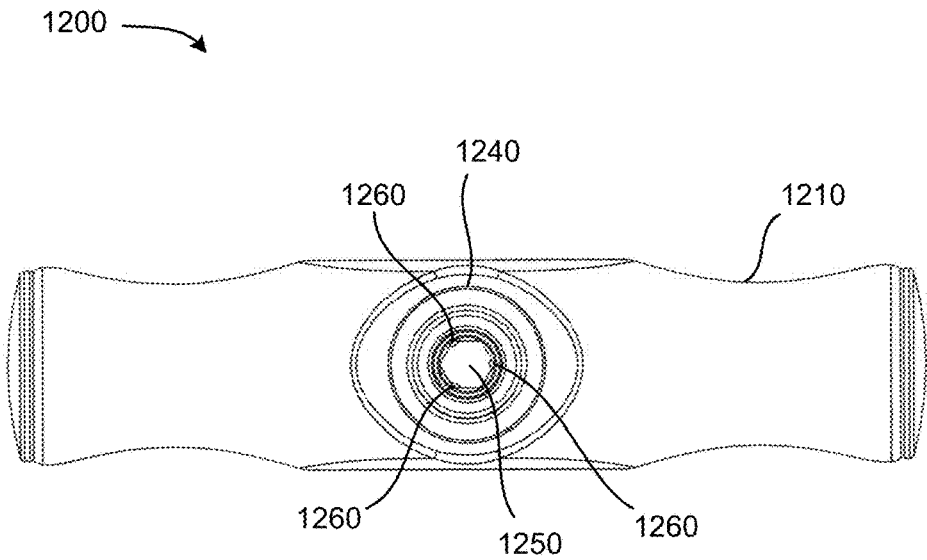

FIG. 12D

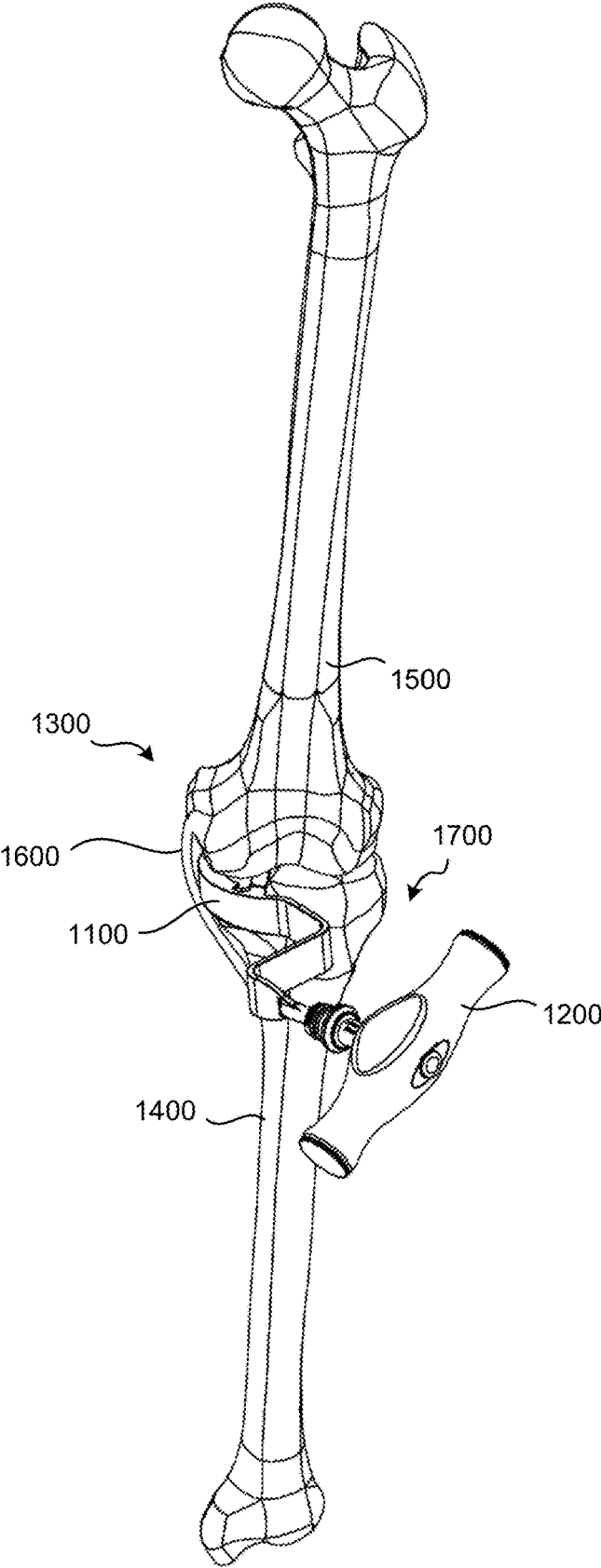

FIG. 13

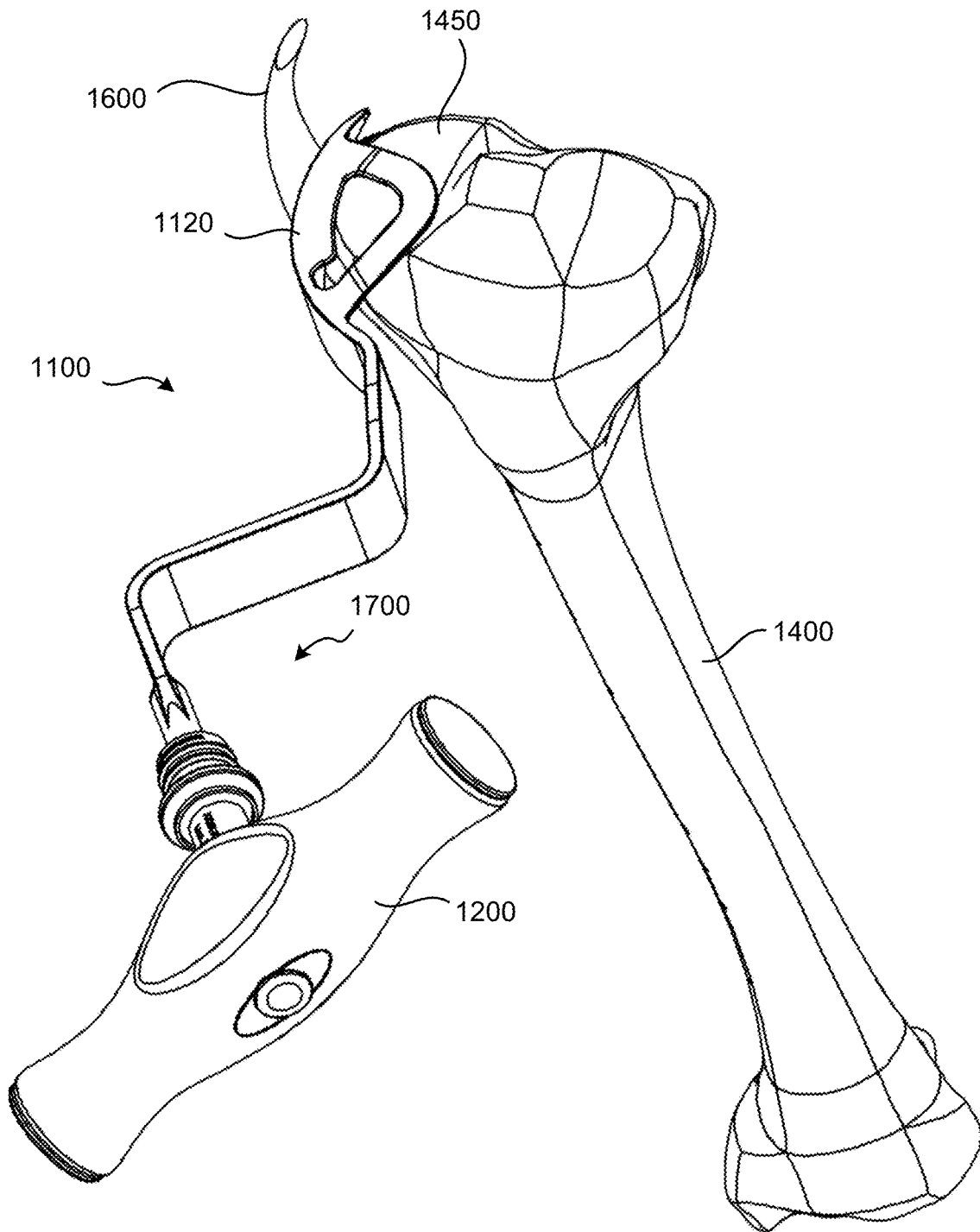

FIG. 14

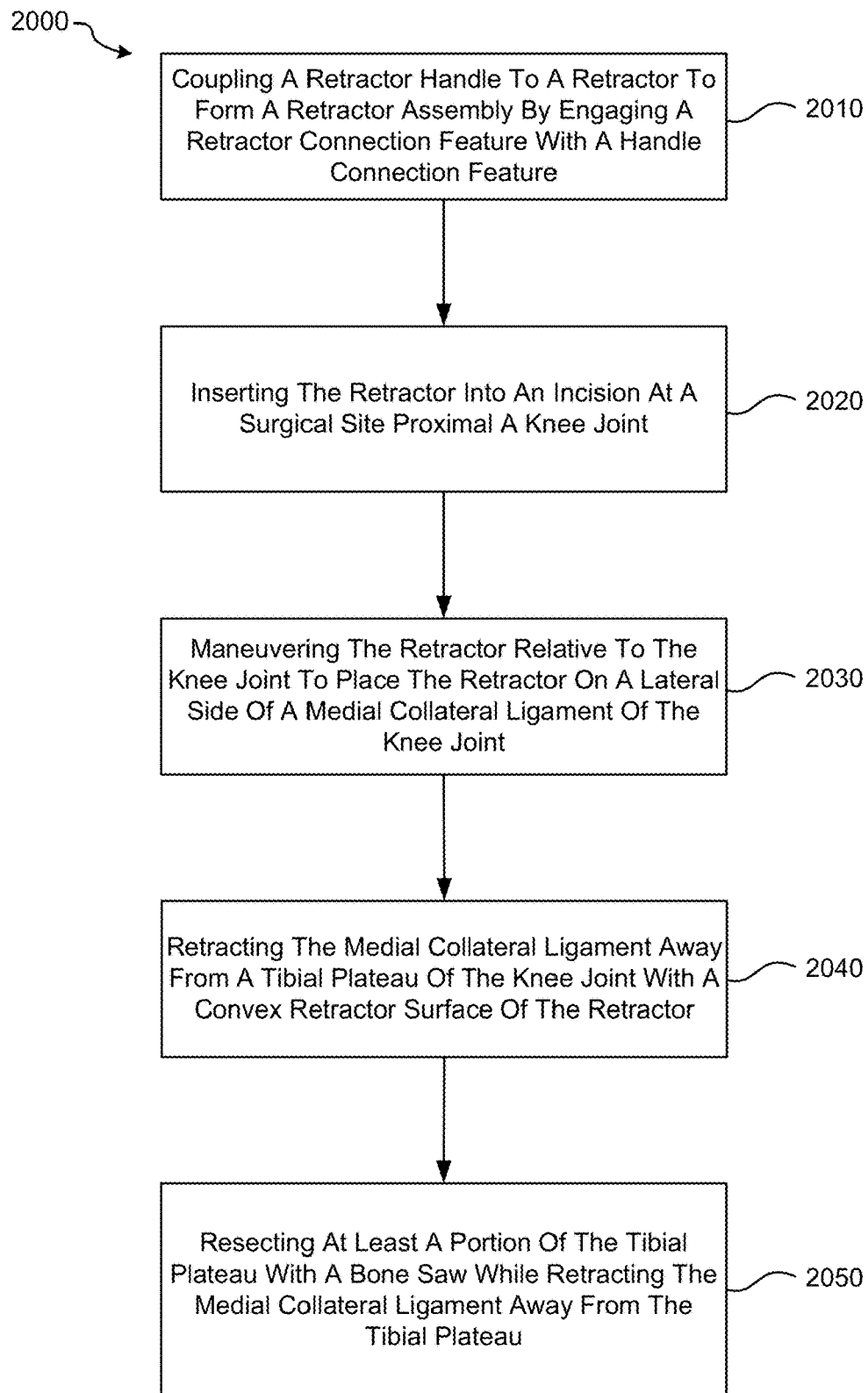

FIG. 15

LIGAMENT RETRACTOR

CROSS-REFERENCE TO RELATED APPLICATIONS

[0001] This application is a continuation-in-part of U.S. patent application Ser. No. 16/803,501 filed on Feb. 27, 2020, entitled “LIGAMENT RETRACTOR” which claims the benefit of U.S. Provisional Patent Application No. 62/812,245 filed on Feb. 28, 2019, entitled “LIGAMENT RETRACTOR”. The above-referenced documents are hereby incorporated by reference in their entirety.

TECHNICAL FIELD

[0002] The present disclosure relates to surgical instruments, systems, and methods. More specifically, the present disclosure relates to improved surgical instruments, systems, and methods for retracting ligaments in order to facilitate surgical procedures, such as a knee joint arthroplasty.

BACKGROUND

[0003] Joint arthroplasty procedures are surgical procedures in which one or more articulating surfaces of a joint are replaced with prosthetic articulating surfaces. Such procedures are becoming increasingly commonplace, particularly for knee joints. An arthroplasty procedure for a knee joint can include implanting a tibial prosthesis to replace the articulating surfaces of the tibia. This may or may not be performed along with replacement of the articulating surfaces of the femur and/or the patella.

[0004] For a successful knee joint arthroplasty, it is important to protect certain ligaments of the knee joint from accidental damage during bone resection operations performed during a knee joint arthroplasty procedure. For example, performing a tibial plateau resection operation can carry an increased risk of accidentally damaging or cutting the medial collateral ligament, especially when a surgeon blindly approaches the medial collateral ligament from the lateral side with a saw blade during a tibial plateau resection procedure.

[0005] Accordingly, surgical instruments, systems, and methods that can reduce or eliminate the risk of accidentally damaging or cutting ligaments during a surgical procedure would be desirable.

SUMMARY

[0006] The various surgical instruments, systems, and methods of the present disclosure have been developed in response to the present state of the art, and in particular, in response to the problems and needs in the art that have not yet been fully solved by currently available surgical instruments, systems, and methods. The surgical instruments, systems, and methods of the present disclosure may provide a reduced risk of accidentally damaging or cutting ligaments during a bone resection operation.

[0007] According to some embodiments, a retractor assembly may include a retractor and a retractor handle. The retractor may include a retractor shaft, a handle connection feature, and a retractor member. The retractor member may be disposed at the distal end of the retractor shaft and may include an arcuate projection having a proximal end coupled to the distal end of the retractor shaft, a distal end transversely projecting away from a first longitudinal axis, a superior surface, an inferior surface, a retractor surface

extending intermediate the superior surface and the inferior surface and including a convex curvature, and a cutting shield surface located opposite the retractor surface extending intermediate the superior surface and the inferior surface. The retractor handle may be configured to removably couple with the retractor and may include a handle portion, a handle shaft coupled to the handle portion, and a retractor connection feature coupled to the handle shaft. The retractor connection feature may be configured to removably couple with the handle connection feature to removably couple the retractor handle with the retractor.

[0008] In some embodiments of the retractor assembly, the retractor member may also include a guide projection coupled to the cutting shield surface and projecting toward the first longitudinal axis. The guide projection may include a superior surface, an inferior surface, and an aperture formed through the guide projection between the superior surface and the inferior surface. The aperture may be shaped to receive at least a portion of a femoral condyle therein to position the retractor member relative to a tibial plateau.

[0009] In some embodiments of the retractor assembly, the retractor shaft may also include a first shaft portion extending along the first longitudinal axis, a second shaft portion extending along a second longitudinal axis, and a third shaft portion extending along a third longitudinal axis. The second shaft portion may be intermediate the first shaft portion and the second shaft portion, and the third shaft portion may be offset from the first shaft portion.

[0010] In some embodiments of the retractor assembly, the handle connection feature may be coupled to the third shaft portion.

[0011] In some embodiments of the retractor assembly, the retractor connection feature may include a locking feature configured to secure the retractor handle to the retractor by engaging the handle connection feature.

[0012] In some embodiments of the retractor assembly, the handle connection feature may include a hex key and a retention slot formed in the hex key.

[0013] In some embodiments of the retractor assembly, the locking feature may include a locking sleeve, a hex socket disposed within the locking sleeve, and one or more ball detents at least partially disposed within an interior space of the hex socket. The hex socket may be configured to receive the hex key, and the one or more ball detents may be configured to engage the retention slot that is formed in the hex key to secure the retractor handle to the retractor.

[0014] According to some embodiments, a retractor may include a retractor shaft, a retractor member, and a guide projection. The retractor member may be disposed at the distal end of the retractor shaft and may include an arcuate projection having a proximal end coupled to the distal end of the retractor shaft, a distal end transversely projecting away from a first longitudinal axis, a superior surface, an inferior surface, a retractor surface extending intermediate the superior and inferior surfaces and having a convex curvature, and a cutting shield surface located opposite the retractor surface and extending intermediate the superior and inferior surfaces. The guide projection may be coupled to the cutting shield surface and may project toward the first longitudinal axis. The guide projection may include a superior surface, an inferior surface, and an aperture formed through the guide projection between the superior surface and the inferior surface. The aperture may be shaped to

receive at least a portion of a femoral condyle therein to position the retractor member relative to a tibial plateau.

[0015] In some embodiments of the retractor, the superior surface and the inferior surface of the guide projection may be configured to taper toward each other moving from the proximal end of the arcuate projection toward the distal end of the arcuate projection.

[0016] In some embodiments of the retractor, the guide projection may also include an outer edge intermediate the superior surface and the inferior surface.

[0017] In some embodiments of the retractor, the outer edge may include a convex surface.

[0018] In some embodiments of the retractor, the distal end of the arcuate projection may include a first tip, a second tip, and a recess intermediate the first tip and the second tip. At least one of the first tip, the second tip, and the recess may be shaped to guide a medial collateral ligament toward the retractor surface as the retractor member is inserted into a knee joint.

[0019] In some embodiments, the retractor may also include a handle connection feature disposed at the proximal end of the retractor shaft.

[0020] In some embodiments, the retractor shaft may also include a first shaft portion extending along the first longitudinal axis, a second shaft portion extending along a second longitudinal axis, and a third shaft portion extending along a third longitudinal axis. The second shaft portion may be located intermediate the first shaft portion and the second shaft portion, and the third shaft portion may be offset from the first shaft portion.

[0021] According to some embodiments, a method for retracting a medial collateral ligament with an assembly including a retractor and a retractor handle is provided. In some embodiments, the retractor may include a handle connection feature and an arcuate projection having a convex retractor surface and a cutting shield surface. In some embodiments, the retractor handle may include a retractor connection feature configured to engage the handle connection feature to removably couple the retractor handle with the retractor. The method may include coupling the retractor handle to the retractor by engaging the retractor connection feature with the handle connection feature, inserting the retractor into an incision at a surgical site proximal a knee joint, maneuvering the retractor relative to the knee joint, and placing the retractor on a lateral side of a medial collateral ligament of the knee joint.

[0022] In some embodiments, the method may also include retracting the medial collateral ligament away from a tibial plateau of the knee joint with the convex retractor surface.

[0023] In some embodiments, the method may also include resecting at least a portion of the tibial plateau with a bone saw while retracting the medial collateral ligament away from the tibial plateau in order to prevent damaging the medial collateral ligament with the bone saw.

[0024] In some embodiments, the method may also include resecting at least a portion of a tibial plateau of the knee joint with a bone saw while the cutting shield surface prevents the bone saw from damaging the medial collateral ligament.

[0025] In some embodiments, the method may also include translating the retractor connection feature between a locked position and an unlocked position to removably couple the retractor handle with the retractor.

[0026] In some embodiments of the method, in the locked position the retractor connection feature may be engaged with the handle connection feature to lock the retractor handle to the retractor, and in an unlocked position the retractor connection feature may be disengaged with the handle connection feature to unlock the retractor handle from the retractor.

[0027] These and other features and advantages of the present disclosure will become more fully apparent from the following description and appended claims, or may be learned by the practice of the instruments, systems, and methods set forth hereinafter.

BRIEF DESCRIPTION OF THE DRAWINGS

[0028] Exemplary embodiments of the disclosure will become more fully apparent from the following description and appended claims, taken in conjunction with the accompanying drawings. Understanding that these drawings depict only exemplary embodiments and are, therefore, not to be considered limiting of the scope of the appended claims, the exemplary embodiments of the present disclosure will be described with additional specificity and detail through use of the accompanying drawings in which:

[0029] FIG. 1A is a perspective view of a retractor, according to an embodiment of the present disclosure;

[0030] FIG. 1B is another perspective view of the retractor of FIG. 1A;

[0031] FIG. 1C is a top view of the retractor of FIG. 1A;

[0032] FIG. 1D is a bottom view of the retractor of FIG. 1A;

[0033] FIG. 1E is a left side view of the retractor of FIG. 1A;

[0034] FIG. 1F is a right side view of the retractor of FIG. 1A;

[0035] FIG. 1G is a perspective top view of the distal end of the retractor of FIG. 1A;

[0036] FIG. 1H is a perspective bottom view of the distal end of the retractor of FIG. 1A;

[0037] FIG. 1I is a left side view of the distal end of the retractor of FIG. 1A;

[0038] FIG. 2A is a perspective view of a guide rod, according to an embodiment of the present disclosure;

[0039] FIG. 2B is another perspective view of the guide rod of FIG. 2A;

[0040] FIG. 2C is a perspective bottom view of the distal end of the guide rod of FIG. 2A;

[0041] FIG. 2D is another perspective bottom view of the distal end of the guide rod of FIG. 2A;

[0042] FIG. 2E is a perspective bottom view of the distal end of the guide rod of FIG. 2A with an alternative hook member shape;

[0043] FIG. 2F is another perspective bottom view of the distal end of the guide rod of FIG. 2E;

[0044] FIG. 2G is a perspective bottom view of the distal end of the guide rod of FIG. 2A with an alternative shape and hook member design;

[0045] FIG. 2H is another perspective bottom view of the distal end of the guide rod of FIG. 2H;

[0046] FIG. 3 is a perspective view of the distal end of the retractor of FIG. 1A and the distal end of the guide rod of FIG. 2A, prior to assembly;

[0047] FIG. 4 is a perspective top view of the distal ends of the retractor and guide rod shown in of FIG. 3, after assembly;

[0048] FIG. 5 is a perspective bottom view of the distal ends of the retractor and guide rod shown in of FIG. 3, after assembly;

[0049] FIG. 6 is a perspective view of the entire assembly of FIGS. 4 and 5;

[0050] FIG. 7 is a perspective view of the assembly of FIG. 6 inserted into a knee joint during a surgical procedure;

[0051] FIG. 8 is a perspective view of the retractor of FIG. 1A relative to a tibia, cutting guide, and bone saw during a tibial plateau resection procedure;

[0052] FIG. 9 is a flowchart of a method for retracting a medial collateral ligament with an assembly during a knee joint arthroplasty procedure;

[0053] FIG. 10 is a flowchart of a method for retracting a medial collateral ligament with a retractor during a knee joint arthroplasty procedure;

[0054] FIG. 11A is a top perspective view of a retractor, according to another embodiment of the present disclosure;

[0055] FIG. 11B is a bottom perspective view of the retractor of FIG. 11A;

[0056] FIG. 11C is a top view of the retractor of FIG. 11A;

[0057] FIG. 11D is a bottom view of the retractor of FIG. 11A;

[0058] FIG. 11 is a left side view of the retractor of FIG. 11A;

[0059] FIG. 11F is a right side view of the retractor of FIG. 11A;

[0060] FIG. 11G is a proximal end view of the retractor of FIG. 11A;

[0061] FIG. 11H is a distal end view of the retractor of FIG. 11A;

[0062] FIG. 12A is a perspective view of a handle, according to an embodiment of the present disclosure;

[0063] FIG. 12B is another perspective view of the handle of FIG. 12A;

[0064] FIG. 12C is a side view of the handle of FIG. 12A;

[0065] FIG. 12D is a distal end view of the handle of FIG. 12A;

[0066] FIG. 13 is a perspective view of the retractor of FIG. 11A inserted into a knee joint during a surgical procedure;

[0067] FIG. 14 is another perspective view of FIG. 13 with the femur bone removed; and

[0068] FIG. 15 is a flowchart of a method for retracting a medial collateral ligament with a retractor assembly during a knee joint arthroplasty procedure.

[0069] It is to be understood that the drawings are for purposes of illustrating the concepts of the disclosure and may not be drawn to scale. Furthermore, the drawings illustrate exemplary embodiments and do not represent limitations to the scope of the present disclosure.

DETAILED DESCRIPTION

[0070] Exemplary embodiments of the present disclosure will be best understood by reference to the drawings, wherein like parts are designated by like numerals throughout. It will be readily understood that the components of the present disclosure, as generally described and illustrated in the Figures herein, could be arranged and designed in a wide variety of different configurations. Thus, the following more detailed description of the embodiments of the apparatus, systems, and method, as represented in the Figures, is not intended to limit the scope of the present disclosure, as claimed in this or any other application claiming priority to

this application, but is merely representative of exemplary embodiments of the present disclosure.

[0071] Standard medical directions, planes of reference, and descriptive terminology are employed in this specification. For example, anterior means toward the front of the body. Posterior means toward the back of the body. Superior, or caudal, means toward the head. Inferior, or cephalad, means toward the feet. Medial means toward the midline of the body. Lateral means away from the midline of the body. Axial means toward a central axis of the body. Abaxial means away from a central axis of the body. Ipsilateral means on the same side of the body. Contralateral means on the opposite side of the body. A sagittal plane divides a body into right and left portions. A midsagittal plane divides the body into bilaterally symmetric right and left halves. A coronal plane divides a body into anterior and posterior portions. A transverse plane divides a body into superior and inferior portions. These descriptive terms may be applied to an animate or inanimate body.

[0072] FIGS. 1A-I illustrate various views of a retractor 100, according to an embodiment of the present disclosure. The retractor 100 may include a proximal end 101, a distal end 102, a retractor handle 110 at the proximal end 101, and a retractor member 120 at the distal end 102 which may be coupled to the retractor handle 110.

[0073] The retractor handle 110 may extend or generally extend along a first longitudinal axis 112, as shown in FIG. 1A. However, it will be understood that the retractor handle 110 or portions of the retractor handle 110 may or may not extend along the first longitudinal axis 112 in a straight line. For example, the phrase “generally extend along an axis” may include straight or curved members that may or may not maintain a close proximity to an axis.

[0074] The retractor member 120 may include a generally arcuate projection, or arcuate projection 130, and a retractor coupling feature (e.g., such as a guide projection 150 having an attachment aperture 160, as one non-limiting example, which will be discussed in more detail below).

[0075] As defined herein, the term “generally arcuate” means having a curved shape, an arc shape, a “bow-like” shape, etc. The term “generally arcuate” can include curved shapes that are mathematically defined by a single radius along a given curved shape, as well as curved shapes that are mathematically defined by a plurality of radii along a given curved shape. However, it will also be understood that the term “generally arcuate” may or may not include curved shapes that are defined by one or more precise mathematical formulas. Moreover, “generally arcuate” may not only include curved shapes that extend along a curvilinear pathway, but also shapes consisting of a series of rectilinear segments that combine to define larger scale curvatures or curved shapes. Thus, for example, a geodesic dome may be said to have a spherical curvature even though the spherical shape is defined by planar segments.

[0076] The arcuate projection 130 may transversely project away from the first longitudinal axis 112. The arcuate projection 130 may include a proximal end 131 (which may be coupled to the retractor handle 110 and/or coupled to a notch 140 formed intermediate the retractor handle 110 and the retractor member 120), a distal end 132, a superior surface 133, and an inferior surface 134. The arcuate projection 130 may also include a retractor surface 135 that extends intermediate the superior surface 133 and the inferior surface 134. In some embodiments, the retractor surface

135 may have a convex curvature. The arcuate projection **130** may further include a cutting shield surface **136**, opposite the retractor surface **135**, which may extend intermediate the superior surface **133** and the inferior surface **134**. In some embodiments, the cutting shield surface **136** may have a concave curvature.

[0077] The distal end **132** of the arcuate projection **130** may include a pointed tip **137**. The distal end **132** of the arcuate projection **130** near the pointed tip **137** may also include a lower concave curvature **138** and a lower convex curvature **139** that may be formed in the inferior surface **134** of the arcuate projection **130**, as shown in FIGS. 1E, 1F, and 1I. Each of the pointed tip **137**, the concave curvature **138**, and/or the convex curvature **139**, may help facilitate maneuvering of the distal end **102** of the retractor **100** within a tight knee joint during a surgical procedure. Moreover, in some embodiments the retractor surface **135** and the cutting shield surface **136** of the arcuate projection **130** may both decrease in height moving from the proximal end **131** of the arcuate projection **130** toward the distal end **132** of the arcuate projection **130** to further aid maneuvering of the distal end **102** of the retractor **100** within a tight knee joint, as can be seen in FIG. 1I.

[0078] In some embodiments, the retractor coupling feature may comprise a guide projection **150**. The guide projection **150** may be coupled to the cutting shield surface **136** of the arcuate projection **130** and may project toward the first longitudinal axis **112**. The guide projection **150** may be configured to rest on top of a tibial plateau during a knee joint arthroplasty procedure in order to help properly place the retractor **100** during a tibial plateau resection, as will be discussed in more detail below. The guide projection **150** may also include an attachment aperture **160** formed in, or through, the guide projection **150**. The attachment aperture **160** may also include a chamfered surface **162**, as will be discussed in more detail below.

[0079] FIGS. 2A-2H illustrate various views of a guide rod **200**, according to embodiments of the present disclosure. The guide rod **200** may include a guide rod handle **210** and an elongate member **220** that may be coupled to the guide rod handle **210** and/or integrally formed therewith. The elongate member **220** may include a proximal end, or rod proximal end **222**, and a rod coupling feature (e.g., such as a hook member **230**, as one non-limiting example, which will be discussed below in more detail) that may be coupled to a distal end, or rod distal end **221**, of the elongate member **220**. The guide rod handle **210** and/or the elongate member **220** may extend or generally extend a long a second longitudinal axis **212**, as shown in FIG. 2A.

[0080] In some embodiments, the rod coupling feature of the guide rod **200** may be configured to engage the retractor coupling feature of the retractor **100** in order to pivotably couple the guide rod **200** to the retractor **100** and form an assembly **10**, as will be discussed below in more detail with respect to FIGS. 3-6.

[0081] Although specific example structures for the retractor coupling feature and the rod coupling feature are presented herein, it will be understood that these are mere exemplary structures given for illustration purposes only. Accordingly, any suitable shape, form, structure, feature, etc., is contemplated herein that can form a retractor coupling feature and/or a corresponding rod coupling feature that may engage with each other to pivotably couple the

guide rod **200** to the retractor **100**, without departing from the spirit or scope of the present disclosure.

[0082] In some embodiments, the rod coupling feature may comprise a hook member **230**. The hook member **230** may transversely project away from the elongate member **220** and/or the second longitudinal axis **212**. The hook member **230** may be shaped to be received within the attachment aperture **160** formed in the guide projection **150** of the retractor **100** in order to pivotably couple the guide rod **200** to the retractor **100**. The hook member **230** may assume any suitable shape in order to pivotably couple the guide rod **200** to the retractor **100**. FIGS. 2C-2H illustrate three non-limiting examples of hook members **230** having different shapes that may be configured to pivotably couple the guide rod **200** to the retractor **100**. However, it will also be understood that any number of differently shaped hook members that can pivotably couple the guide rod **200** to the retractor **100** are envisioned herein. The hook member **230** may include a first side **231**, a second side **232**, a superior side **233**, a distal hook surface **234**, a proximal hook surface **235**, and a hook member tip **236**.

[0083] In some embodiments, the proximal hook surface **235** may extend about a proximal end **237** of the hook member **230** from the first side **231** to the second side **232**.

[0084] In some embodiments, at least a portion of the proximal hook surface **235** may extend toward the guide rod handle **210**, or rod proximal end **222**, at a first angle. The shape and/or angle of the proximal hook surface **235** may be selected to facilitate pivotable coupling of the guide rod **200** to the retractor **100**.

[0085] In some embodiments, the hook member tip **236** may extend or project toward the rod proximal end **222** above at least a portion of the proximal hook surface **235**.

[0086] In some embodiments, at least a portion of the proximal hook surface **235** may comprise a cam surface configured to interact with a surface associated with the attachment aperture **160**.

[0087] In some embodiments, at least a portion of the proximal hook surface **235** may be concave.

[0088] In some embodiments, at least a portion of the proximal hook surface **235** may be convex.

[0089] In some embodiments, at least a portion of the distal hook surface **234** may extend or generally extend toward the guide rod handle **210**, or rod proximal end **222**, at a second angle.

[0090] In some embodiments, the shape and/or second angle of the distal hook surface **234** on a distal end **238** of the hook member **230** may be selected to engage the chamfered surface **162** of the attachment aperture **160** in order to facilitate decoupling of the guide rod **200** from the retractor **100** when a distally directed force of sufficient magnitude is applied to the guide rod **200** relative to the retractor **100**.

[0091] In some embodiments, the first side **231** and the second side **232** may angle together towards the superior side **233** of the hook member **230**.

[0092] FIG. 3 is a perspective view of the distal ends of the retractor **100** and guide rod **200** before they are assembled together. A surgeon may assemble the retractor **100** and the guide rod **200** together by inserting the hook member **230** into the attachment aperture **160** in the direction of arrow **240** shown in FIG. 3.

[0093] FIGS. 4-6 illustrate various perspective views of the retractor **100** and guide rod **200** after they have been

assembled together to form an assembly 10. As previously discussed, the guide rod 200 may be decoupled from the retractor 100 by applying a distally directed force of sufficient magnitude to the guide rod 200. This will cause the distal hook surface 234 (which may be angled as discussed above) to engage the chamfered surface 162 that surrounds the attachment aperture 160 (which may also be angled in a complementary fashion to the distal hook surface 234) in order to decouple the guide rod 200 from the retractor 100.

[0094] FIG. 7 is a perspective view of the assembly 10 inserted into a knee joint 300 during a surgical procedure. The knee joint 300 may include a tibia 400, a femur 500, and a medial collateral ligament 600. The guide rod 200, pivotably coupled to the retractor 100, helps prevent the distal end of the retractor 100 from being accidentally placed on the medial side of the medial collateral ligament 600 during insertion of the by the surgeon. Rather, the guide rod 200 will help ensure that the distal end of the retractor 100 will be placed on the lateral side of the medial collateral ligament 600 by the surgeon during insertion. Once the distal end of the retractor 100 has been properly positioned on the lateral side of the medial collateral ligament 600, the guide rod 200 may be decoupled from the retractor 100 (as previously discussed) and removed from the knee joint 300.

[0095] FIG. 8 is a perspective view of the retractor 100, a tibia 401, a cutting guide 700 engaged with the tibia 401, and a bone saw 800, in preparation for a tibial plateau resection procedure. The retractor 100 may be utilized by a surgeon to retract a medial collateral ligament of the knee joint (not shown in FIG. 8) away from the tibial plateau during the resection procedure. The cutting shield surface 136 of the retractor 100 may also act as a mechanical stop to the blade of the bone saw 800 to further protect the medial collateral ligament from accidental damage or cutting during the tibial plateau resection procedure.

[0096] FIG. 9 is a flowchart of a method 900 for retracting a medial collateral ligament with an assembly 10 during a knee joint arthroplasty procedure. The assembly 10 may include a retractor 100 having a retractor coupling feature and a guide rod 200 having a rod coupling feature configured to engage the retractor coupling feature to pivotably couple the guide rod 200 to the retractor 100.

[0097] The method 900 may begin with a step 910 in which the guide rod 200 may be pivotally coupled to the retractor 100 to create the assembly 10 by engaging the rod coupling feature with the retractor coupling feature. In some embodiments, this may be accomplished by inserting a hook member 230 of the guide rod 200 into an attachment aperture 160 formed in the distal end of the retractor 100.

[0098] Once the guide rod 200 has been coupled to the retractor 100, the method 900 may proceed to a step 920 in which the assembly 10 may be inserted into an incision (not shown) at a surgical site proximal a knee joint.

[0099] Once the assembly 10 has been inserted into the incision, the method 900 may proceed to a step 930 in which the assembly 10 may be maneuvered relative to the knee joint in order to place the assembly 10 on a lateral side of a medial collateral ligament of the knee joint. The guide rod 200, coupled to the retractor 100, can ensure the retractor 100 does not end up on the medial side of the medial collateral ligament, as previously discussed.

[0100] Alternatively, or in addition thereto, once the assembly 10 has been placed on the lateral side of the medial collateral ligament, the method 900 may proceed to

a step 940 in which the guide rod 200 may be decoupled from the retractor 100 by applying a distal force to the guide rod 200 relative to the retractor 100, as previously discussed. The decoupled guide rod 200 may then be removed from the knee joint in a step 950.

[0101] Once the guide rod 200 has been decoupled from the retractor 100 and removed from the knee joint, the method 900 may proceed to a step 960 in which the surgeon may utilize the retractor 100 to retract the medial collateral ligament away from a tibial plateau of the knee joint.

[0102] Alternatively, or in addition thereto, the method 900 may proceed to a step 970 in which a portion of the tibial plateau may be resected with a bone saw while the medial collateral ligament is retracted away from the tibia, and the method 900 may end.

[0103] In this manner, the medial collateral ligament may be protected from damage by the bone saw during the resection procedure. The retractor 100 may protect the medial collateral ligament in at least two ways including: (1) via retraction, which increases a separation distance between the bone saw blade and the medial collateral ligament, thus decreasing the likelihood of damaging the medial collateral ligament; and (2) the cutting shield surface 136 of the retractor 100 may directly shield the medial collateral ligament from the bone saw blade to prevent the bone saw blade from damaging the medial collateral ligament. Thus, the cutting shield surface 136 can help in all instances where the separation distance achieved from retraction may or may not be sufficient to keep the medial collateral ligament away from the bone saw blade.

[0104] FIG. 10 is a flowchart of a method 1000 for retracting a medial collateral ligament of a knee joint with a retractor 100. In some embodiments, the retractor 100 may include an arcuate projection having a retractor surface 135 that may be convex and a cutting shield surface 136 that may be concave.

[0105] The method 1000 may begin with a step 1010 in which the retractor 100 may be inserted into an incision (not shown) at a surgical site proximal the knee joint.

[0106] Once the retractor 100 has been inserted into the incision, the method 1000 may proceed to a step 1020 in which the retractor 100 may be maneuvered relative to the knee joint in order to locate the retractor 100 on a lateral side of the medial collateral ligament.

[0107] Once the retractor 100 has been located on the lateral side of the medial collateral ligament, the method 1000 may proceed to a step 1030 in which the surgeon may utilize the retractor surface 135 of the retractor 100 to retract the medial collateral ligament away from a tibial plateau of the knee joint.

[0108] Alternatively, or in addition thereto, the method 1000 may proceed to a step 1040 in which a portion of the tibial plateau may be resected with a bone saw while the medial collateral ligament is retracted away from the tibia in order to prevent the bone saw from damaging the medial collateral ligament.

[0109] Alternatively, or in addition thereto, the method 1000 may proceed to a step 1050 in which a portion of the tibial plateau may be resected with a bone saw while the cutting shield surface 136 of the retractor 100 directly prevents the bone saw from damaging the medial collateral ligament, and the method 1000 may end.

[0110] Thus, as previously discussed, the medial collateral ligament may be protected from damage by the bone saw

during the resection procedure. The retractor **100** may protect the medial collateral ligament including: (1) via retraction, which increases a separation distance between the bone saw blade and the medial collateral ligament, thus decreasing the likelihood of damaging the medial collateral ligament; and (2) the cutting shield surface **136** of the retractor **100** may directly shield the medial collateral ligament from the bone saw blade to prevent the bone saw blade from damaging the medial collateral ligament.

[0111] FIGS. 11A-11H illustrate various views of a retractor **1100**, according to another embodiment of the present disclosure. The retractor **1100** may include a proximal end **1101**, a distal end **1102**, a retractor shaft or shaft **1110**, a handle connection feature **1114** at the proximal end **1101** of the retractor **1100**, and a retractor member **1120** at the distal end **1102** of the retractor **1100**.

[0112] In some embodiments, the shaft **1110** may include a first shaft portion **1111**, a second shaft portion **1112**, and a third shaft portion **1113**. In this manner, the third shaft portion **1113** may be offset from the first shaft portion **1111** to provide extra clearance and working space for the surgeon, as will be discussed in more detail below. The first shaft portion **1111** may extend or generally extend along a first longitudinal axis **1121**, the second shaft portion **1112** may extend or generally extend along a second longitudinal axis **1122**, and the third shaft portion **1113** may extend or generally extend along a third longitudinal axis **1123**. However, it will be understood that any portion of the shaft **1110** may or may not extend along a particular longitudinal axis in a straight line and may generally include straight or curved members that may or may not maintain a close proximity to a particular longitudinal axis.

[0113] In some embodiments, the handle connection feature **1114** may be coupled to and/or extend proximally from the third shaft portion **1113**.

[0114] In some embodiments, the handle connection feature **1114** may be configured to removably couple with a handle, as will be discussed in more detail below with respect to FIGS. 12A-D.

[0115] In some embodiments, the handle connection feature **1114** may comprise a hex key **1116**, with a retention slot **1117** formed therein. However, it will be understood that the handle connection feature **1114** may comprise any conceivable shape or configuration to couple a handle to the handle connection feature **1114**.

[0116] In some embodiments, the retractor **1100** may include an integrally formed handle (not shown) in lieu of the handle connection feature **1114**.

[0117] In some embodiments, the retractor member **1120** may include a generally arcuate projection, or arcuate projection **1130**, and a guide projection **1150**.

[0118] The arcuate projection **1130** may transversely project away from the first longitudinal axis **1121**. The arcuate projection **1130** may include a proximal end **1131** (which may be coupled to the first shaft portion **1111**), a distal end **1132**, a superior surface **1133**, and an inferior surface **1134**.

[0119] In some embodiments, the superior surface **1133** and the inferior surface **1134** may taper toward each other moving from the proximal end **1131** of the arcuate projection **1130** toward the distal end **1132** of the arcuate projection **1130**, as shown in FIG. 11H.

[0120] The arcuate projection **1130** may also include a retractor surface **1135** (see FIGS. 11E and 11H) that extends intermediate the superior surface **1133** and the inferior

surface **1134**. The retractor surface **1135** may have a convex curvature. The arcuate projection **1130** may further include a cutting shield surface **1136**, opposite the retractor surface **1135**, which may extend intermediate the superior surface **1133** and the inferior surface **1134**. In some embodiments, the cutting shield surface **1136** may have a concave curvature.

[0121] In some embodiments, the distal end **1132** of the arcuate projection **1130** may include a first tip **1141** and a second tip **1142** separated by a recess **1143**. At least one of the first tip **1141**, the second tip **1142**, and/or the recess **1143** may be tapered and/or otherwise shaped to guide a medial collateral ligament toward the retractor surface **1135** as the retractor member **1120** is inserted into a knee joint. Moreover, at least one of the first tip **1141**, the second tip **1142**, and/or the recess **1143** may be tapered and/or otherwise shaped to help separate tissue during insertion and/or facilitate maneuvering of the distal end **1102** of the retractor **1100** within a tight knee joint during a surgical procedure. In some embodiments, the retractor surface **1135** and the cutting shield surface **1136** of the arcuate projection **1130** may both decrease in height moving from the proximal end **1131** of the arcuate projection **1130** toward the distal end **1132** of the arcuate projection **1130** to further aid maneuvering of the distal end **1102** of the retractor **1100** within a tight knee joint, as can be seen in FIG. 11H.

[0122] The guide projection **1150** may include a superior surface **1151**, an inferior surface **1152**, and an outer edge **1153** intermediate the superior surface **1151** and the inferior surface **1152**. The guide projection **1150** may be configured to rest on top of a tibial plateau during a knee joint arthroplasty procedure in order to help properly place the retractor **1100** during a tibial plateau resection (see FIGS. 13 and 14).

[0123] In some embodiments, the guide projection **1150** may be coupled to the cutting shield surface **1136** and project toward the first longitudinal axis **1121**.

[0124] In some embodiments, the outer edge **1153** of the guide projection **1150** may include a convex surface.

[0125] In some embodiments, the superior surface **1151** and the inferior surface **1152** may taper toward each other moving from the proximal end **1131** of the arcuate projection **1130** toward the distal end **1132** of the arcuate projection **1130** (see FIG. 11F). This taper may help separate tissue and/or facilitate maneuvering of the distal end **1102** of the retractor **1100** within a tight knee joint during a surgical procedure.

[0126] In some embodiments, an aperture **1160** may be formed in or through the guide projection **1150**.

[0127] In some embodiments, the aperture **1160** may be shaped to receive at least a portion of a femoral condyle therein to help locate, position, hold, and/or retain the retractor member **1120** relative to at least one of the femoral condyle and a tibial plateau of a knee joint during a surgical procedure (e.g., see FIG. 13).

[0128] In some embodiments, the retractor **1100** may be inserted into, positioned within, and/or removed from a knee joint without the use of an additional guide rod (such as the guide rod **200** described herein). However, it will also be understood that in other embodiments the retractor **1100** may be inserted into, positioned within, and/or removed from a knee joint with the use of an additional guide rod that

may couple with the aperture **1160** via a suitable hook member (e.g., such as the guide rod **200** and hook member **230** described herein).

[0129] FIGS. 12A-D illustrate various views of a retractor handle, or handle **1200**, according to an embodiment of the present disclosure. The handle **1200** may include a handle portion **1210**, a handle shaft **1220**, and a retractor connection feature **1230**.

[0130] In some embodiments, the handle **1200** may be removably couplable with the retractor **1100**.

[0131] In some embodiments, the retractor connection feature **1230** may comprise a locking feature that may be configured to secure the handle **1200** to the retractor **1100**.

[0132] In some embodiments, the locking feature may comprise a locking sleeve **1240**, a hex socket **1250**, and one or more pins or one or more ball detents **1260** that may be configured to lock the handle **1200** to the handle connection feature **1114** of the retractor **1100**.

[0133] In some embodiments, the locking sleeve **1240** and/or the one or more ball detents **1260** may be spring biased. For example, the locking sleeve **1240** may be spring biased such that the locking sleeve **1240** is pushed distally along the handle shaft **1220**. Moreover, the one or more ball detents **1260** may be spring biased such that they are pushed inwardly into the interior space of the hexsocket **1250**.

[0134] In some embodiments, the handle **1200** may be coupled with the retractor **1100** by: (1) translating the locking sleeve **1240** proximally along the handle shaft **1220** to allow the one or more ball detents **1260** to withdraw from the interior space of the hex socket **1250**; (2) inserting the hex key **1116** of the handle connection feature **1114** into the hex socket **1250** of the retractor connection feature **1230**; and (3) releasing/translating the locking sleeve **1240** distally along the handle shaft **1220** to force the one or more ball detents **1260** to enter into the retention slot **1117** formed in the hex key **1116** to secure the handle **1200** to the retractor **1100**.

[0135] In some embodiments, the handle **1200** may be decoupled from the retractor **1100** by: (1) translating the locking sleeve **1240** proximally along the handle shaft **1220** to allow the one or more ball detents **1260** to withdraw from the retention slot **1117**; and (2) removing the hex key **1116** from the hex socket **1250** to decouple the handle **1200** from the retractor **1100**.

[0136] FIG. 13 is a perspective view of the retractor **1100** coupled to the handle **1200** to form a retractor assembly **1700**, with the retractor **1100** inserted into a knee joint **1300** during a surgical procedure. FIG. 14 illustrates another perspective view of FIG. 13 with the femur bone removed to show the retractor member **1120** engaged with the tibial plateau **1450**. The knee joint **1300** may include a tibia **1400**, a femur **1500**, and a medial collateral ligament **1600**. As previously described herein, the morphology of the retractor **1100** may help with insertion of the retractor **1100** and/or may help prevent the distal end **1102** of the retractor **1100** from being accidentally placed on the medial side of the medial collateral ligament **1600** during insertion of the retractor **1100** by the surgeon. Rather, the morphology of the retractor **1100** will help ensure that the distal end **1102** of the retractor **1100** will be placed on the lateral side of the medial collateral ligament **1600** by the surgeon during insertion. Once the distal end **1102** of the retractor **1100** has been properly positioned on the lateral side of the medial collateral ligament **1600**, the tibial plateau may be resected with

a bone saw in a similar manner to that shown and described in FIG. 8. Thus, the retractor **1100** may be utilized by a surgeon to retract a medial collateral ligament of the knee joint away from a tibial plateau during the resection procedure. The cutting shield surface **1136** of the retractor **1100** may also act as a mechanical stop to the blade of a bone saw to further protect the medial collateral ligament from accidental damage or cutting during the tibial plateau resection procedure.

[0137] FIG. 15 is a flowchart of a method **2000** for retracting a medial collateral ligament with a retractor assembly **1700** during a knee joint arthroplasty procedure. The retractor assembly **1700** may include a retractor **1100** and a handle **1200**. In some embodiments, the retractor **1100** may include a handle connection feature **1114**, a guide projection **1150**, and an arcuate projection **1130** having a retractor surface **1135** that may be convex and a cutting shield surface **1136** that may be concave. The handle **1200** may include a retractor connection feature **1230** configured to engage the handle connection feature **1114** to removably couple the handle **1200** with the retractor **1100**.

[0138] The method **2000** may begin with a step **2010** in which a handle **1200** may be coupled to a retractor **1100** to form a retractor assembly **1700** by engaging a retractor connection feature **1230** with a handle connection feature **1114**, as previously described herein.

[0139] Once the retractor handle **1200** has been coupled to the retractor **1100** to form the retractor assembly **1700**, the method **2000** may proceed to a step **2020** in which the retractor **1100** may be inserted into an incision (not shown) at a surgical site proximal the knee joint.

[0140] Once the retractor **1100** has been inserted into the incision, the method **2000** may proceed to a step **2030** in which the retractor **1100** may be maneuvered relative to the knee joint in order to place the retractor **1100** on a lateral side of the medial collateral ligament. In some embodiments, the guide projection **1150** and/or the arcuate projection **1130** of the retractor **1100** may traverse inferior to a medial meniscus (not shown) of the knee joint during placement of the retractor **1100** with respect to the knee joint. Moreover, in some embodiments positioning the guide projection **1150** of the retractor **1100** over a medial tibial plateau (not shown) of the knee joint may indicate that the arcuate projection **1130** of the retractor **1100** is interposed between the medial collateral ligament and the medial tibial plateau of the knee joint.

[0141] Once the retractor **1100** has been placed on the lateral side of the medial collateral ligament, the method **2000** may proceed to a step **2040** in which the surgeon may utilize the retractor surface **1135** of the retractor **1100** to retract the medial collateral ligament away from a tibial plateau of the knee joint.

[0142] Alternatively, or in addition thereto, the method **2000** may proceed to a step **2050** in which a portion of the tibial plateau may be resected with a bone saw while the medial collateral ligament is retracted away from the tibia in order to prevent the bone saw from damaging the medial collateral ligament with the cutting shield surface **1136** of the retractor **1100** further preventing the bone saw from damaging the medial collateral ligament, and the method **2000** may end.

[0143] In this manner, the medial collateral ligament may be protected from damage by the bone saw during the resection procedure. The retractor **1100** may protect the

medial collateral ligament in at least two ways including: (1) via retraction, which increases a separation distance between the bone saw blade and the medial collateral ligament, thus decreasing the likelihood of damaging the medial collateral ligament; and (2) the cutting shield surface **1136** of the retractor **1100** may directly shield the medial collateral ligament from the bone saw blade to prevent the bone saw blade from damaging the medial collateral ligament. Thus, the cutting shield surface **1136** can help in all instances where the separation distance achieved from retraction may or may not be sufficient to keep the medial collateral ligament away from the bone saw blade.

[0144] Any methods disclosed herein may comprise one or more steps or actions for performing the described method. One or more of the method steps or actions may be omitted from any of the methods disclosed herein. Moreover, any of the method steps or actions may be interchanged with one another. In other words, unless a specific order of steps or actions is required for proper operation of the embodiment, the order and/or use of specific steps or actions may be modified.

[0145] It will also be understood that any of the ligament retractor instruments, components, assemblies, systems, and/or methods that are described herein may be mixed and matched in any number of combinations without departing from the spirit or scope of the present disclosure. For example, the retractor **100** of FIGS. **1A-1I** and/or the retractor **1100** of FIGS. **11A-11H** may be utilized with the guide rod **200** including any of the hook member **230** embodiments shown in FIGS. **2C-2H**, etc. As another non-limiting example, the hook member **230** may be coupled with the guide projection **150** (instead of the guide rod **200**) and the attachment aperture **160** may be formed in the guide rod **200** (instead of the guide projection **150**), etc. As another non-limiting example, the handle **1200** may be utilized with the retractor **100** and/or the retractor handle **110** may be utilized with the retractor **1100**, etc. As another non-limiting example, the guide projections **150** and **1150** may be utilized with any of the retractors **100**, **1100** disclosed herein.

[0146] The word “exemplary” is used herein to mean “serving as an example, instance, or illustration.” Any embodiment described herein as “exemplary” is not necessarily to be construed as preferred or advantageous over other embodiments. While the various aspects of the embodiments are presented in drawings, the drawings are not necessarily drawn to scale unless specifically indicated.

[0147] Reference throughout this specification to “an embodiment” or “the embodiment” means that a particular feature, structure, or characteristic described in connection with that embodiment is included in at least one embodiment. Thus, the quoted phrases, or variations thereof, as recited throughout this specification are not necessarily all referring to the same embodiment.

[0148] Similarly, it should be appreciated that in the above description of embodiments, various features are sometimes grouped together in a single embodiment, Figure, or description thereof for the purpose of streamlining the disclosure. This method of disclosure, however, is not to be interpreted as reflecting an intention that any claim requires more features than those expressly recited in that claim. Rather, as the following claims reflect, inventive aspects lie in a combination of fewer than all features of any single foregoing disclosed embodiment. Thus, the claims following this Detailed Description are hereby expressly incorporated

into this Detailed Description, with each claim standing on its own as a separate embodiment. This disclosure includes all permutations of the independent claims with their dependent claims.

[0149] Recitation in the claims of the term “first” with respect to a feature or element does not necessarily imply the existence of a second or additional such feature or element. Elements recited in means-plus-function format are intended to be construed in accordance with 35 U.S.C. § 112 Para. 6. It will be apparent to those having skill in the art that changes may be made to the details of the above-described embodiments without departing from the underlying principles set forth herein.

[0150] The phrases “connected to,” “coupled to,” “engaged with,” and “in communication with” refer to any form of interaction between two or more entities, including mechanical, electrical, magnetic, electromagnetic, fluid, and thermal interaction. Two components may be functionally coupled to each other even though they are not in direct contact with each other. The term “abutting” refers to items that are in direct physical contact with each other, although the items may not necessarily be attached together. The phrase “fluid communication” refers to two features that are connected such that a fluid within one feature is able to pass into the other feature. The phrase “substantially equal” can mean within about a + or -10% relative variance from one another.

[0151] While specific embodiments and applications of the present disclosure have been illustrated and described, it is to be understood that the scope of the appended claims is not limited to the precise configuration and components disclosed herein. Various modifications, changes, and variations which will be apparent to those skilled in the art may be made in the arrangement, operation, and details of the devices, systems, and methods disclosed herein.

What is claimed is:

1. A retractor assembly comprising:
 - a retractor, the retractor comprising:
 - a retractor shaft, the retractor shaft comprising:
 - a proximal end; and
 - a distal end;
 - wherein at least a portion of the retractor shaft extends along a first longitudinal axis;
 - a handle connection feature disposed at the proximal end of the retractor shaft; and
 - a retractor member disposed at the distal end of the retractor shaft, the retractor member comprising:
 - an arcuate projection, the arcuate projection comprising:
 - a proximal end coupled to the distal end of the retractor shaft;
 - a distal end transversely projecting away from the first longitudinal axis;
 - a superior surface;
 - an inferior surface;
 - a retractor surface extending intermediate the superior surface and the inferior surface, the retractor surface comprising a convex curvature; and
 - a cutting shield surface located opposite the retractor surface and extending intermediate the superior surface and the inferior surface; and
 - a retractor handle configured to removably couple with the retractor, the retractor handle comprising:

- a handle portion;
 - a handle shaft coupled to the handle portion; and
 - a retractor connection feature coupled to the handle shaft;
 - wherein the retractor connection feature is configured to removably couple with the handle connection feature to removably couple the retractor handle with the retractor.
2. The retractor assembly of claim 1, wherein the retractor member further comprises:
- a guide projection coupled to the cutting shield surface and projecting toward the first longitudinal axis, the guide projection comprising:
 - a superior surface;
 - an inferior surface; and
 - an aperture formed through the guide projection between the superior surface and the inferior surface; wherein the aperture is shaped to receive at least a portion of a femoral condyle therein to position the retractor member relative to a tibial plateau.
3. The retractor assembly of claim 1, wherein the retractor shaft further comprises:
- a first shaft portion extending along the first longitudinal axis;
 - a second shaft portion extending along a second longitudinal axis; and
 - a third shaft portion extending along a third longitudinal axis;
 - wherein the second shaft portion is intermediate the first shaft portion and the second shaft portion, and the third shaft portion is offset from the first shaft portion.
4. The retractor assembly of claim 3, wherein the handle connection feature is coupled to the third shaft portion.
5. The retractor assembly of claim 1, wherein the retractor connection feature comprises a locking feature configured to secure the retractor handle to the retractor by engaging the handle connection feature.
6. The retractor assembly of claim 5, wherein the handle connection feature comprises:
- a hex key; and
 - a retention slot formed in the hex key.
7. The retractor assembly of claim 6, wherein the locking feature comprises:
- a locking sleeve;
 - a hex socket disposed within the locking sleeve; and
 - one or more ball detents at least partially disposed within an interior space of the hex socket;
 - wherein the hex socket is configured to receive the hex key, and the one or more ball detents are configured to engage the retention slot formed in the hex key to secure the retractor handle to the retractor.
8. A retractor comprising:
- a retractor shaft, the retractor shaft comprising:
 - a proximal end; and
 - a distal end;
 - wherein at least a portion of the retractor shaft extends along a first longitudinal axis; and
 - a retractor member disposed at the distal end of the retractor shaft, the retractor member comprising:
 - an arcuate projection, the arcuate projection comprising:
 - a proximal end coupled to the distal end of the retractor shaft;
 - a distal end transversely projecting away from the first longitudinal axis;
 - a superior surface;
 - an inferior surface;
 - a retractor surface extending intermediate the superior surface and the inferior surface, the retractor surface comprising a convex curvature; and
 - a cutting shield surface located opposite the retractor surface and extending intermediate the superior surface and the inferior surface; and
 - a guide projection coupled to the cutting shield surface and projecting toward the first longitudinal axis, the guide projection comprising:
 - a superior surface;
 - an inferior surface; and
 - an aperture formed through the guide projection between the superior surface and the inferior surface; wherein the aperture is shaped to receive at least a portion of a femoral condyle therein to position the retractor member relative to a tibial plateau.
9. The retractor of claim 8, wherein the superior surface and the inferior surface of the guide projection are configured to taper toward each other moving from the proximal end of the arcuate projection toward the distal end of the arcuate projection.
10. The retractor of claim 8, wherein the guide projection further comprises an outer edge intermediate the superior surface and the inferior surface.
11. The retractor of claim 10, wherein the outer edge comprises a convex surface.
12. The retractor of claim 8, wherein the distal end of the arcuate projection further comprises:
- a first tip;
 - a second tip; and
 - a recess intermediate the first tip and the second tip;
 - wherein at least one of the first tip, the second tip, and the recess is shaped to guide a medial collateral ligament toward the retractor surface as the retractor member is inserted into a knee joint.
13. The retractor of claim 8, further comprising a handle connection feature disposed at the proximal end of the retractor shaft.
14. The retractor of claim 8, wherein the retractor shaft comprises:
- a first shaft portion extending along the first longitudinal axis;
 - a second shaft portion extending along a second longitudinal axis; and
 - a third shaft portion extending along a third longitudinal axis;
 - wherein the second shaft portion is intermediate the first shaft portion and the second shaft portion, and the third shaft portion is offset from the first shaft portion.
15. A method for retracting a medial collateral ligament with an assembly comprising a retractor and a retractor handle, the retractor comprising a handle connection feature and an arcuate projection having a convex retractor surface and a cutting shield surface, the retractor handle comprising a retractor connection feature configured to engage the handle connection feature to removably couple the retractor handle with the retractor, the method comprising:
- coupling the retractor handle to the retractor by engaging the retractor connection feature with the handle connection feature;

inserting the retractor into an incision at a surgical site proximal a knee joint;

maneuvering the retractor relative to the knee joint; and placing the retractor on a lateral side of a medial collateral ligament of the knee joint.

16. The method of claim **15**, further comprising:

retracting the medial collateral ligament away from a tibial plateau of the knee joint with the convex retractor surface.

17. The method of claim **16**, further comprising:

resecting at least a portion of the tibial plateau with a bone saw while retracting the medial collateral ligament away from the tibial plateau in order to prevent damaging the medial collateral ligament with the bone saw.

18. The method of claim **15**, further comprising:

resecting at least a portion of a tibial plateau of the knee joint with a bone saw while the cutting shield surface prevents the bone saw from damaging the medial collateral ligament.

19. The method of claim **15**, further comprising:

translating the retractor connection feature between a locked position and an unlocked position to removably couple the retractor handle with the retractor.

20. The method of claim **19**, wherein:

in the locked position, the retractor connection feature is engaged with the handle connection feature to lock the retractor handle to the retractor; and

in an unlocked position, the retractor connection feature is disengaged with the handle connection feature to unlock the retractor handle from the retractor.

* * * * *