



US 20210161681A1

(19) **United States**

(12) **Patent Application Publication**  
NGUYEN et al.

(10) **Pub. No.: US 2021/0161681 A1**

(43) **Pub. Date: Jun. 3, 2021**

(54) **UNIVERSAL FEMORAL TRIAL SYSTEM AND METHODS**

on Jul. 26, 2017, provisional application No. 62/537, 106, filed on Jul. 26, 2017, provisional application No. 62/466,249, filed on Mar. 2, 2017.

(71) Applicant: **Optimotion Implants LLC**, Orlando, FL (US)

(72) Inventors: **Vuong Binh NGUYEN**, Windermere, FL (US); **Andrew RYNEARSON**, Winter Springs, FL (US); **Daniel F. JUSTIN**, Orlando, FL (US); **Dinesh V. KOKA**, Winter Springs, FL (US)

(73) Assignee: **Optimotion Implants LLC**, Orlando, FL (US)

(21) Appl. No.: **17/164,796**

(22) Filed: **Feb. 1, 2021**

**Related U.S. Application Data**

(63) Continuation-in-part of application No. 16/505,595, filed on Jul. 8, 2019, Continuation-in-part of application No. 16/046,583, filed on Jul. 26, 2018, now Pat. No. 10,940,024, Continuation-in-part of application No. 16/046,554, filed on Jul. 26, 2018, Continuation-in-part of application No. 15/622,688, filed on Jun. 14, 2017, now Pat. No. 10,905,436.

(60) Provisional application No. 62/694,834, filed on Jul. 6, 2018, provisional application No. 62/537,106, filed

**Publication Classification**

(51) **Int. Cl.**  
*A61F 2/46* (2006.01)  
*A61B 17/17* (2006.01)  
(52) **U.S. Cl.**  
CPC ..... *A61F 2/4684* (2013.01); *A61F 2/3859* (2013.01); *A61B 17/1764* (2013.01); *A61B 17/17* (2013.01)

(57) **ABSTRACT**

Implant assemblies, systems, kits, and methods for replacing a knee joint may include a universal femoral trial component for preparing and trialing a femoral bone of a patient to receive a plurality of different femoral implant types. The assembly may include a body and drill guide and an attachment mechanism including first and second compressible tabs and a rotatable handle operationally connected to the first and second tabs. The universal femoral trial component may be configured to receive any of a plurality of femoral bone preparation attachments and any of a plurality of femoral trial attachments in order to facilitate the preparation and trialing of the femoral bone to receive the plurality of different femoral implant types.

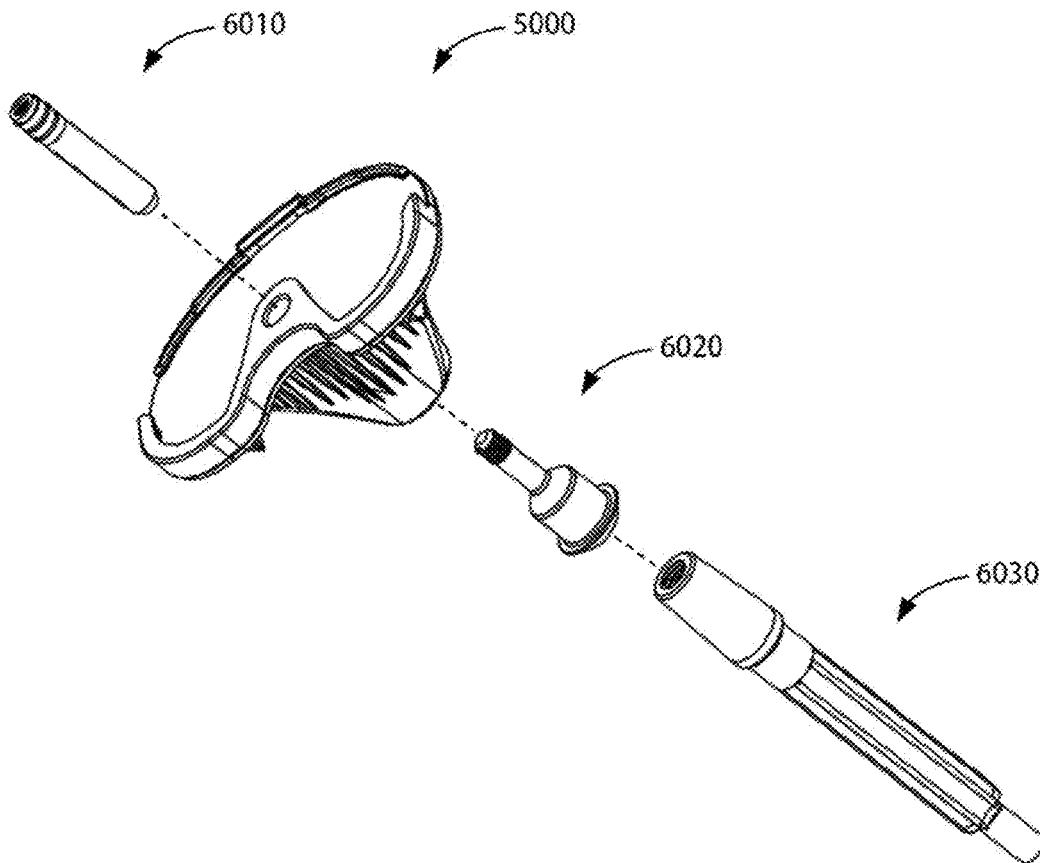

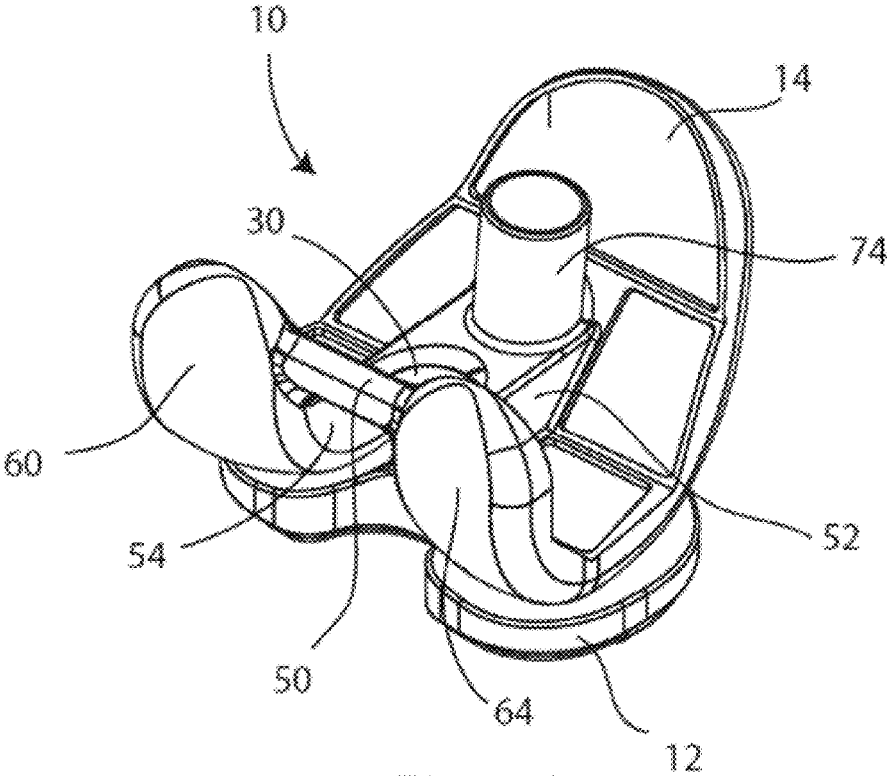

Fig. 1A

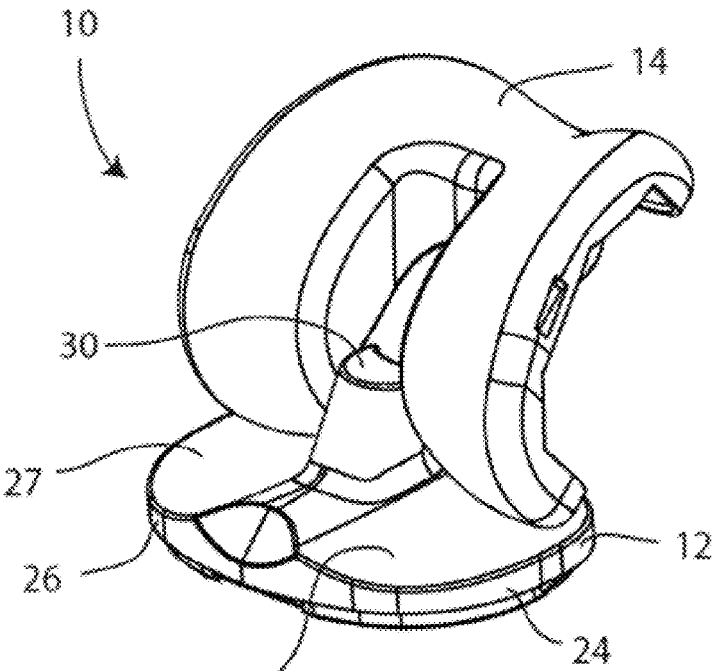

Fig. 1B

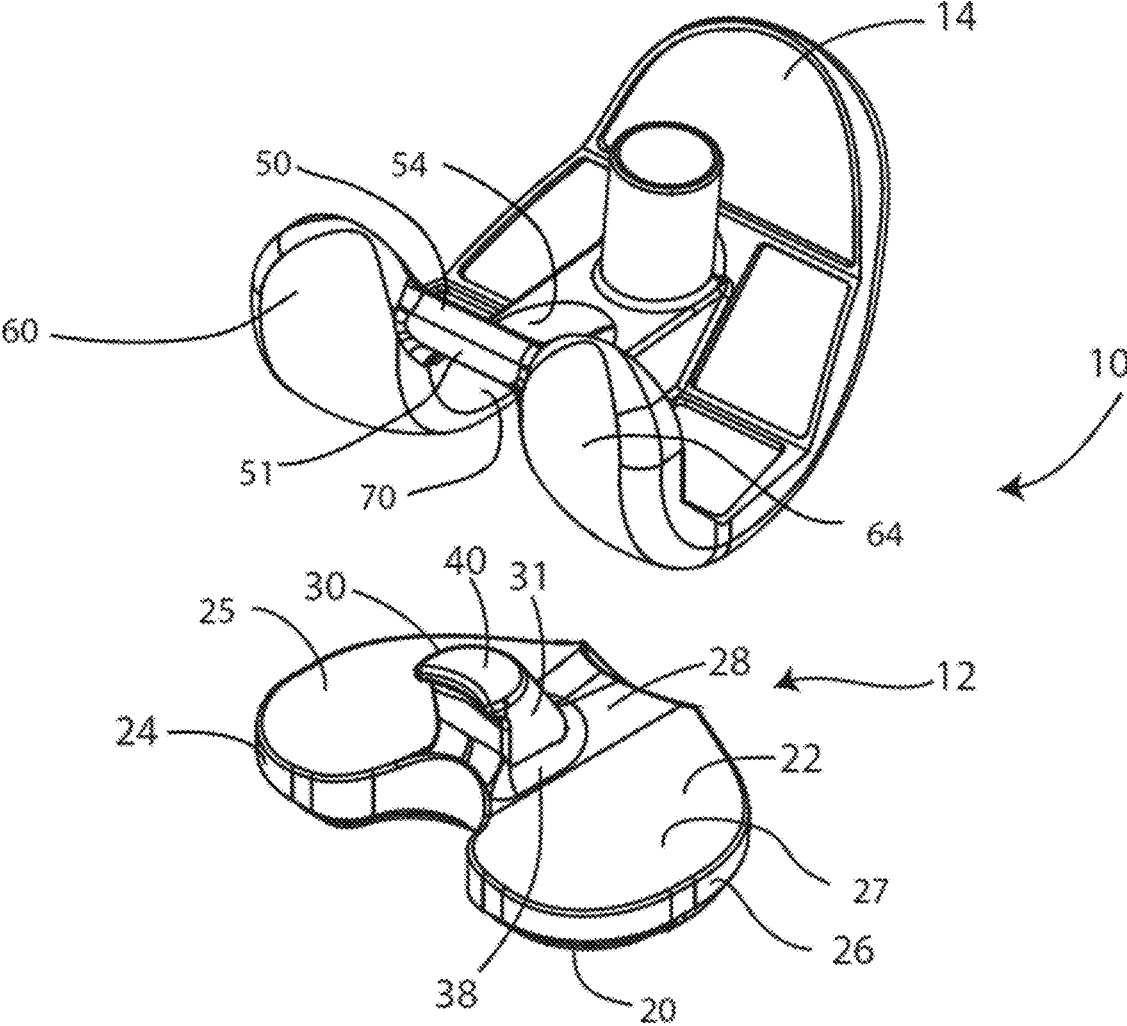

Fig. 2

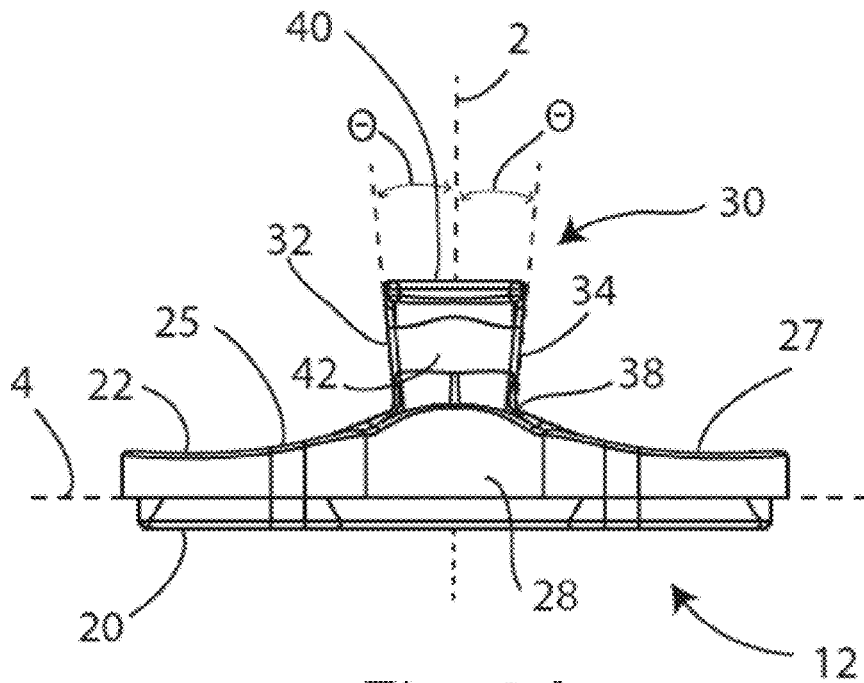

Fig. 3A

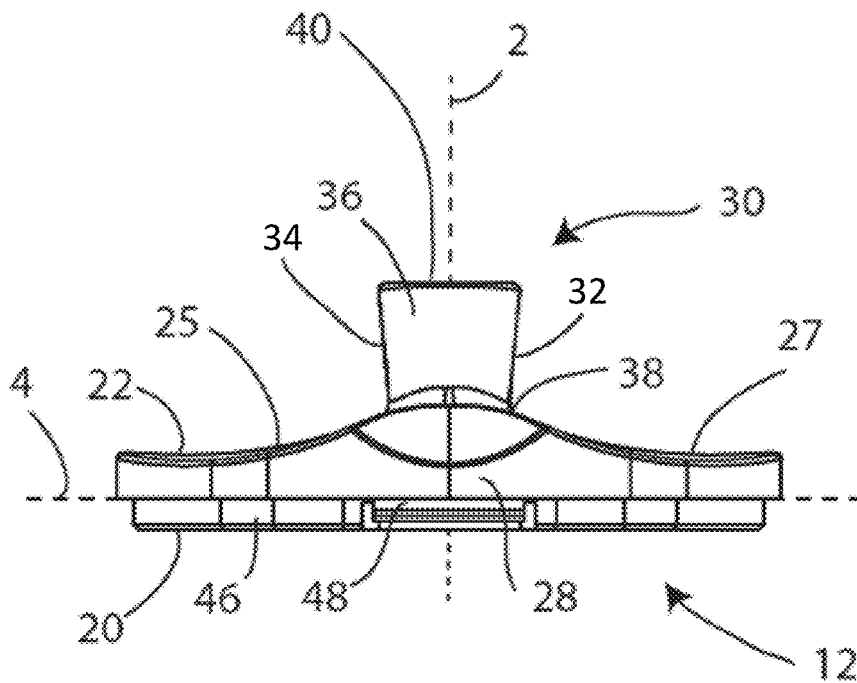

Fig. 3B

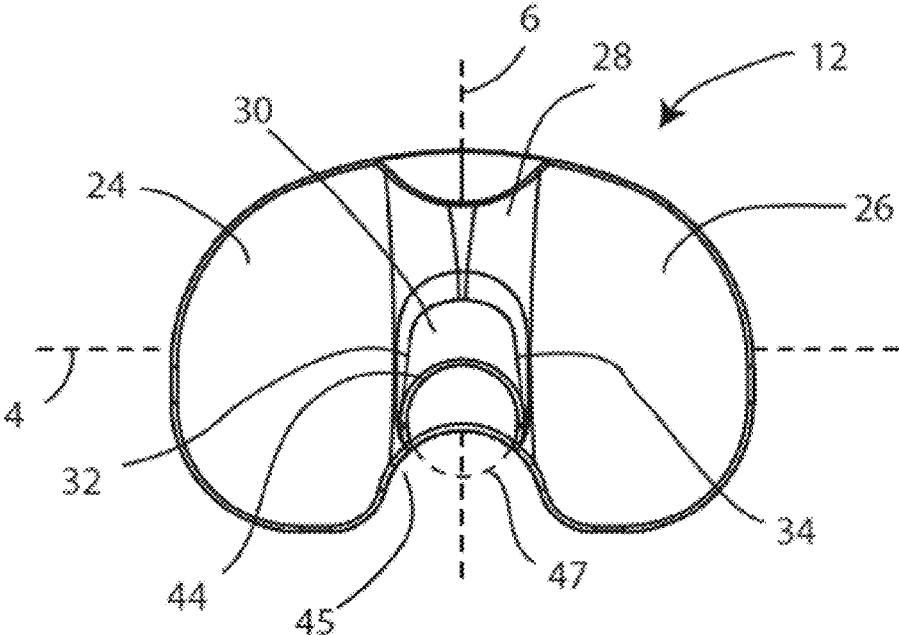

Fig. 3C

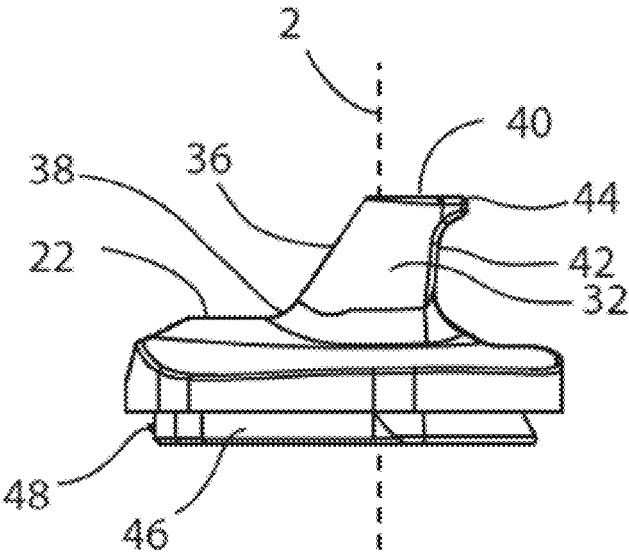

Fig. 3D

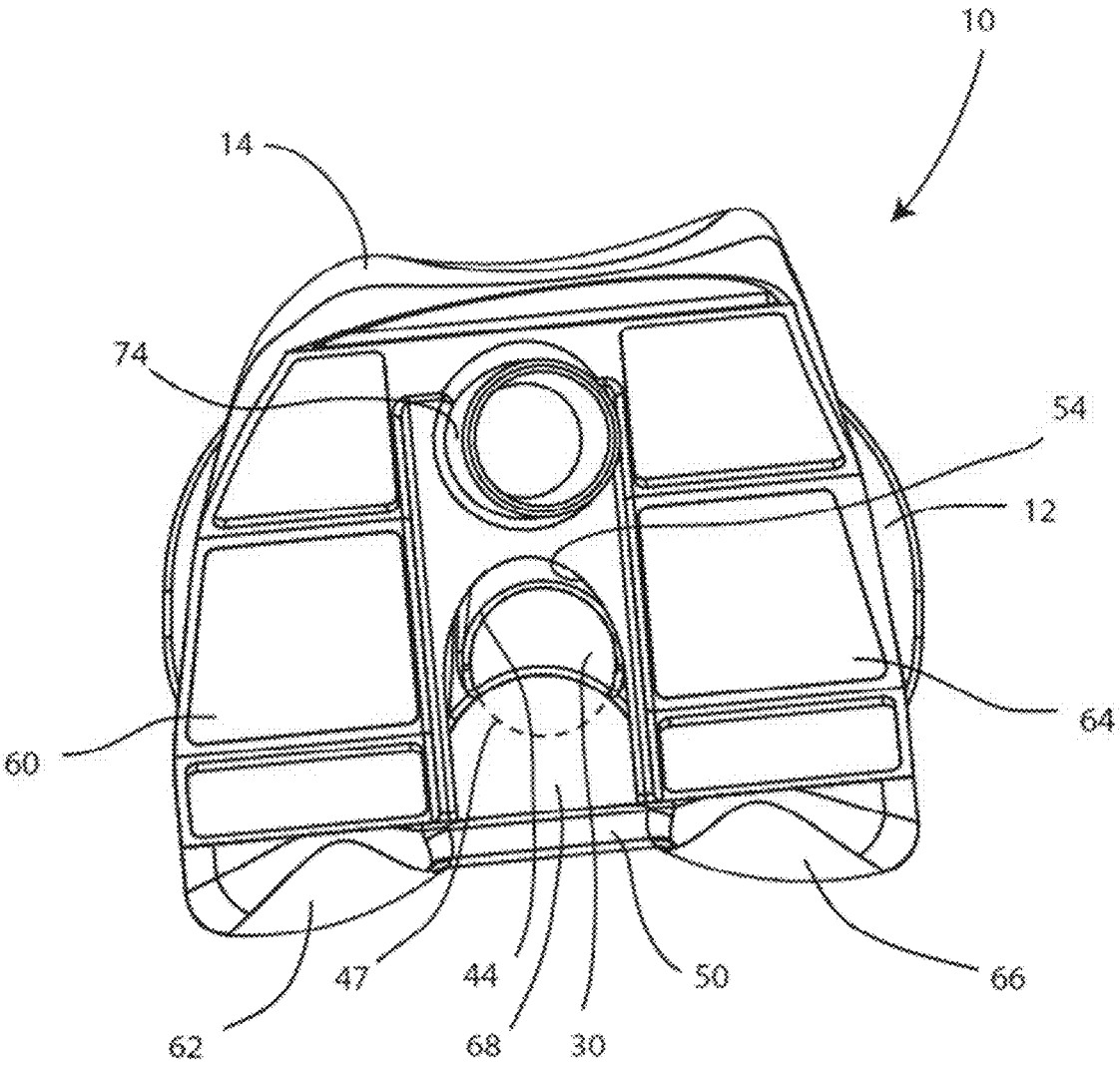

Fig. 4

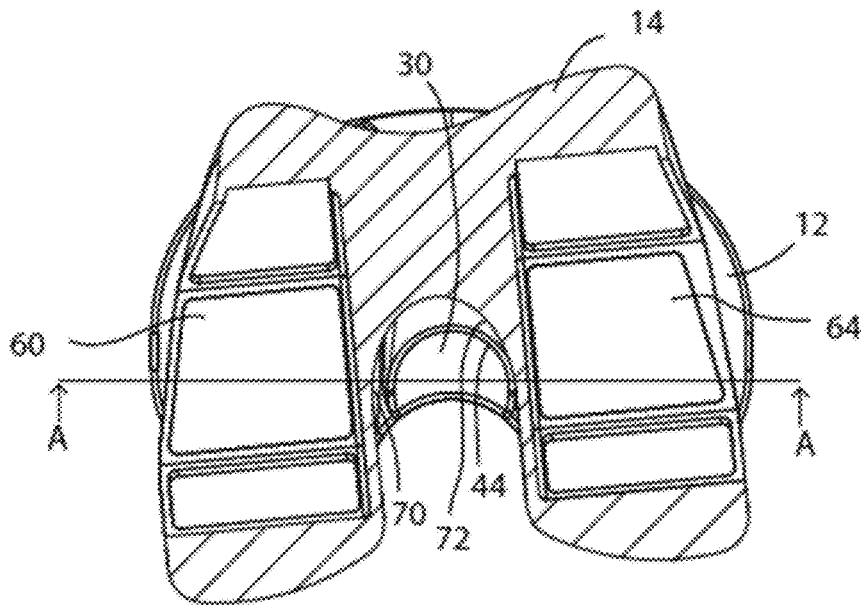

Fig. 5

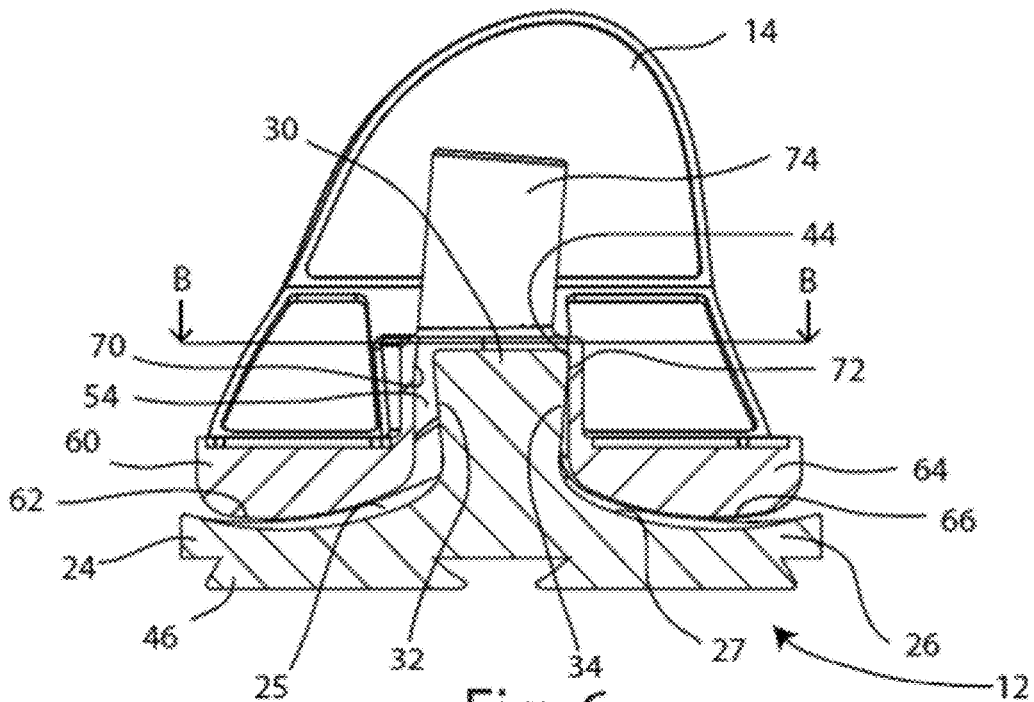

Fig. 6

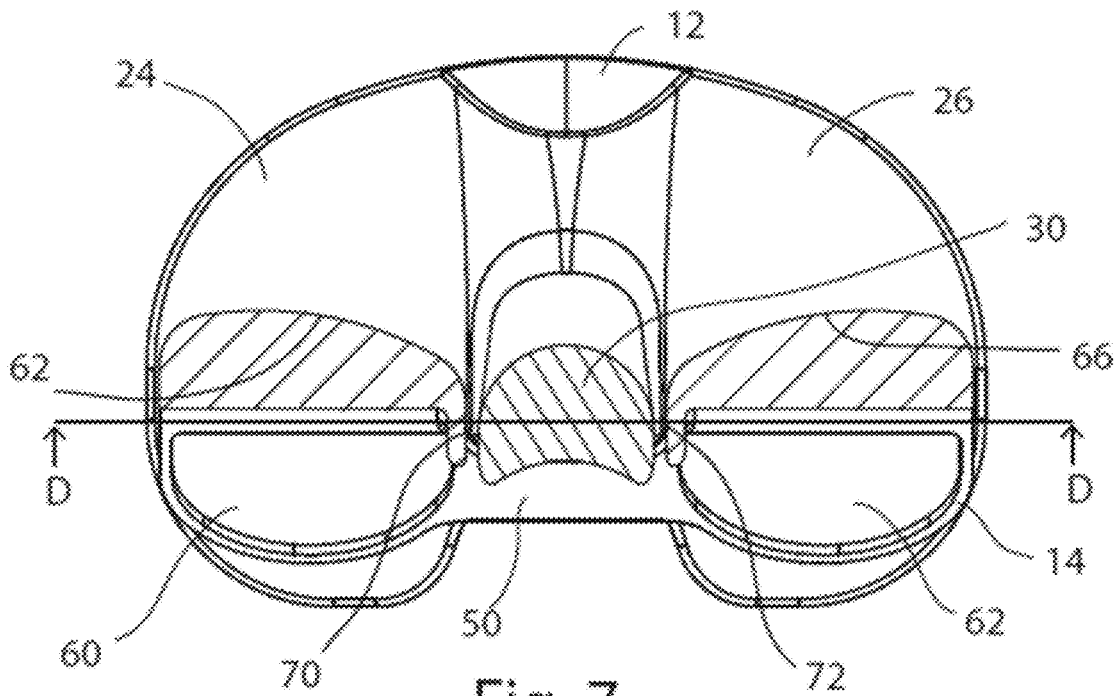

Fig. 7

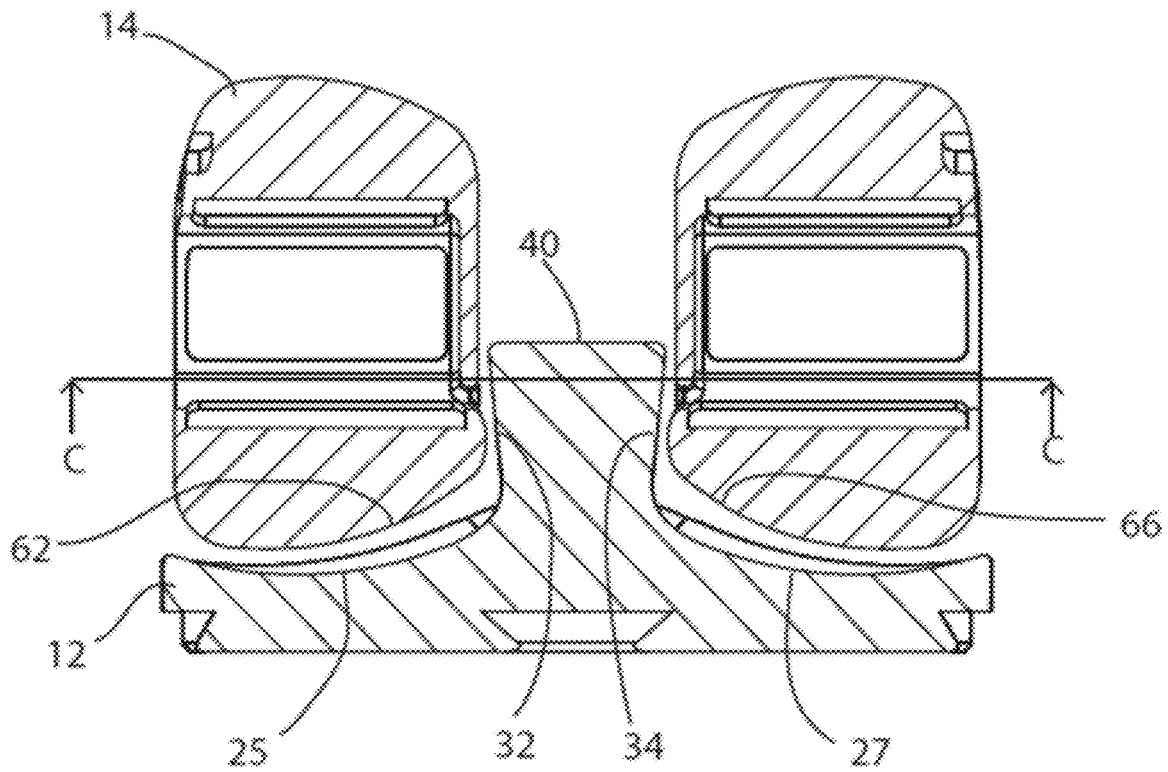

Fig. 8



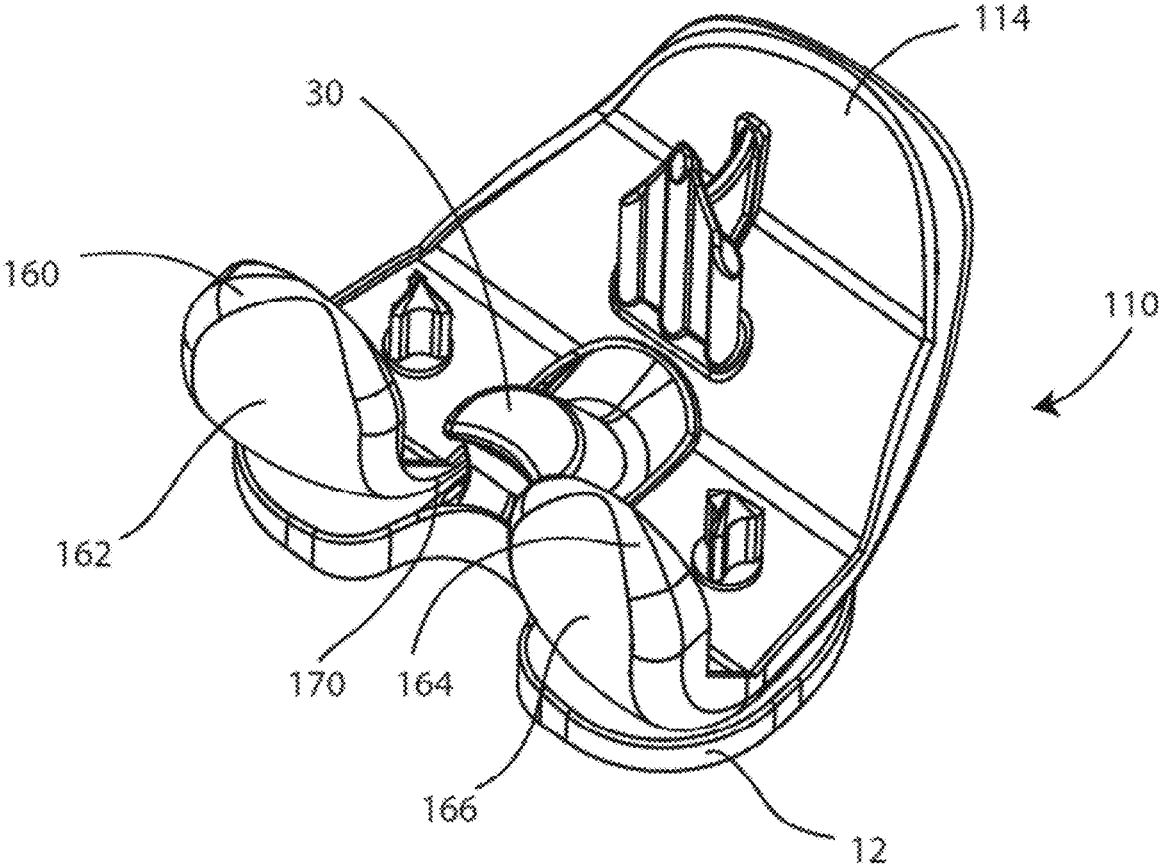

Fig. 9

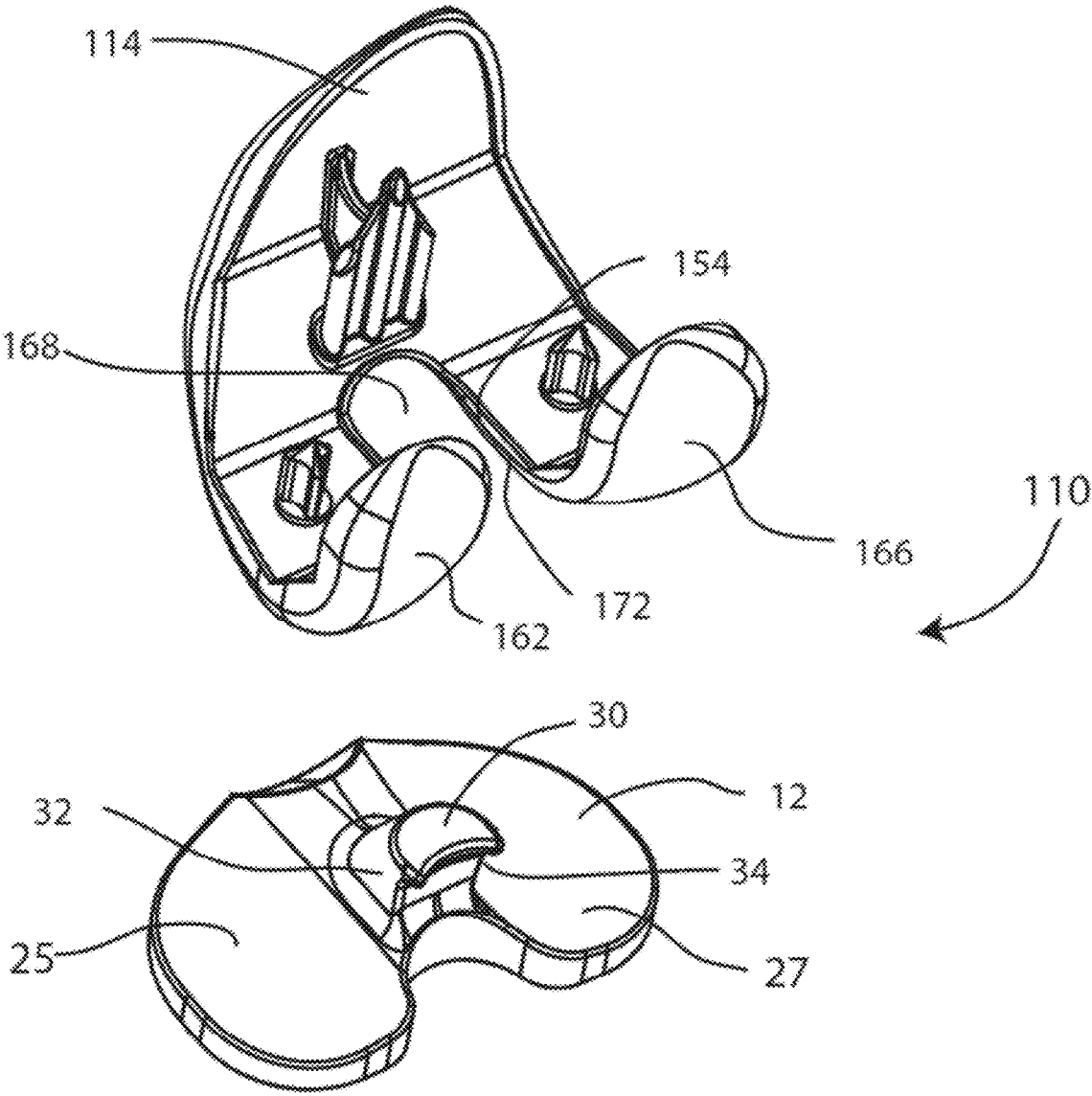
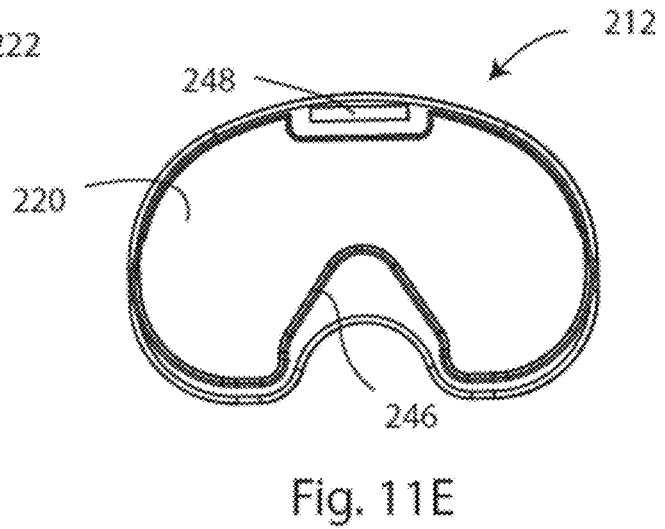
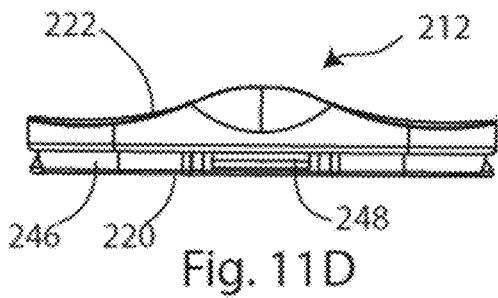
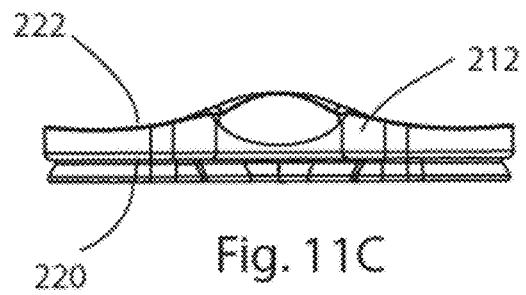
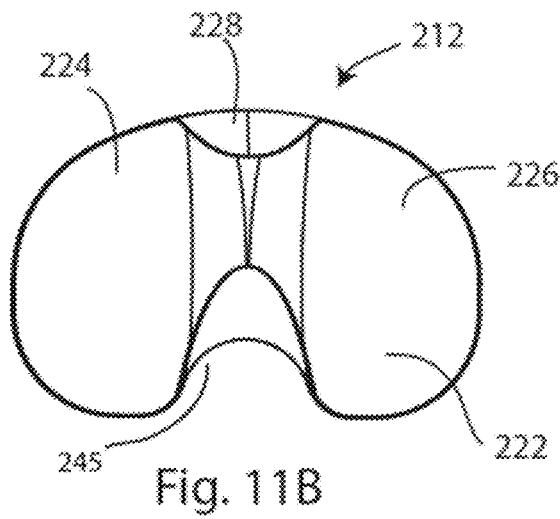
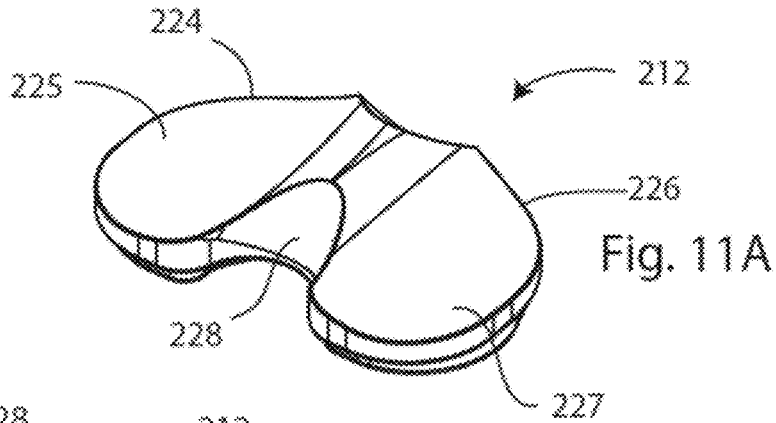
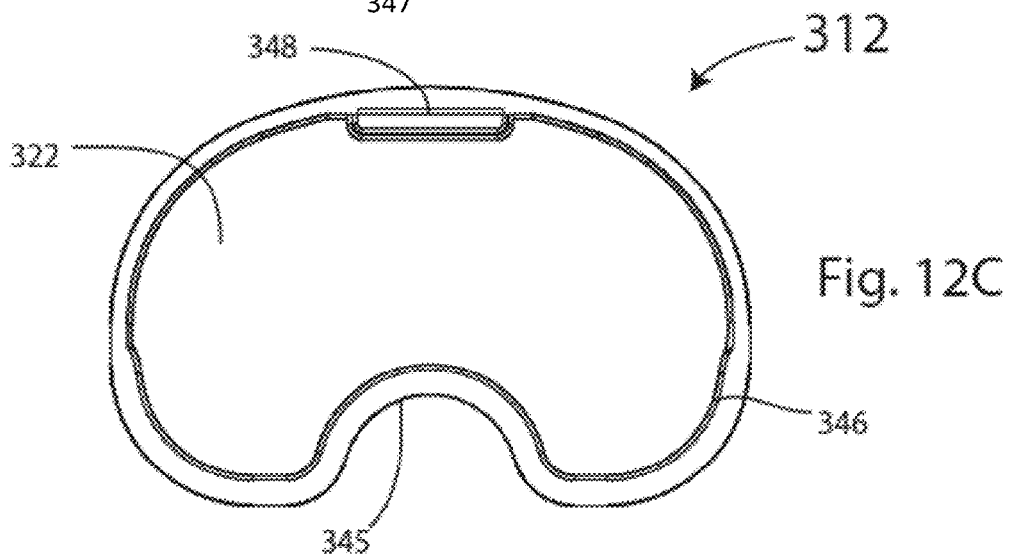
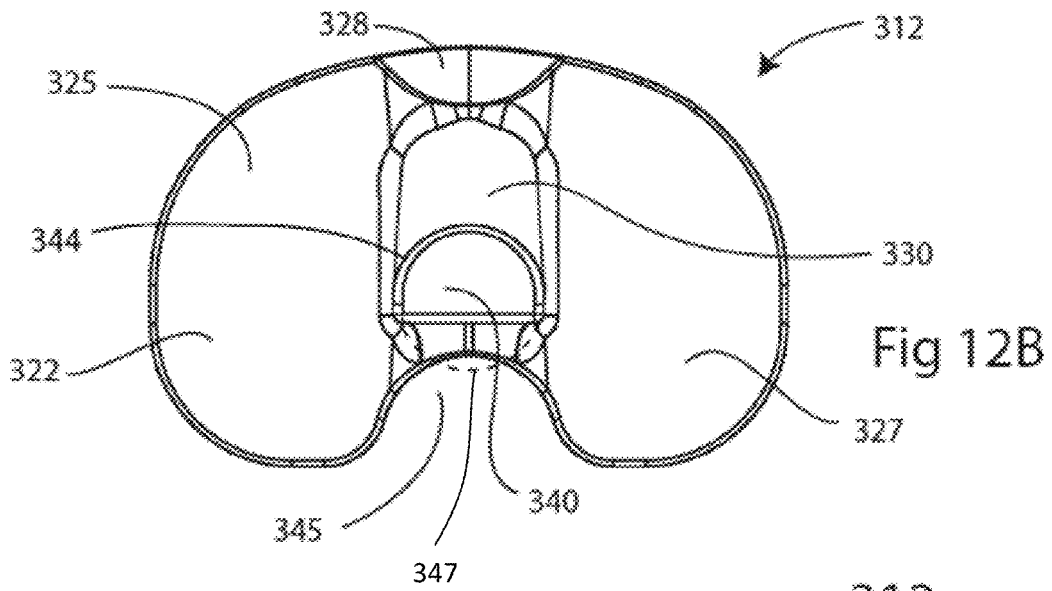
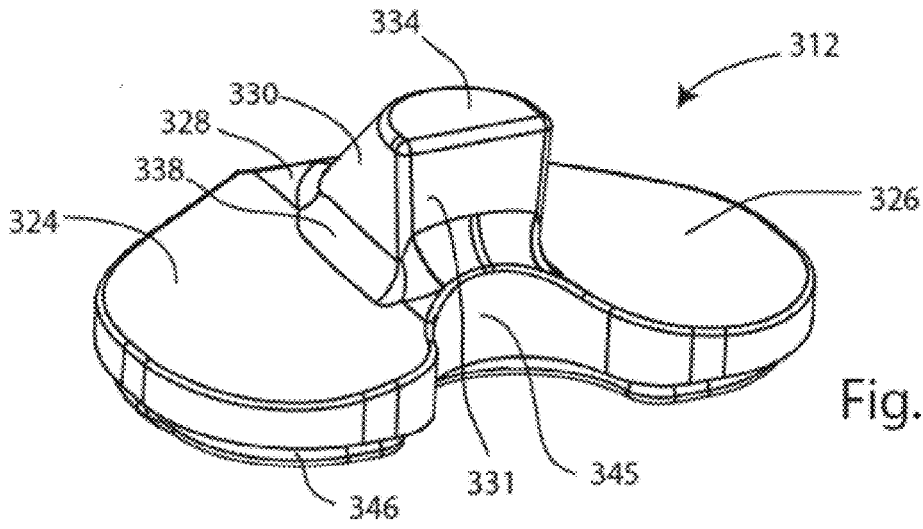

Fig. 10





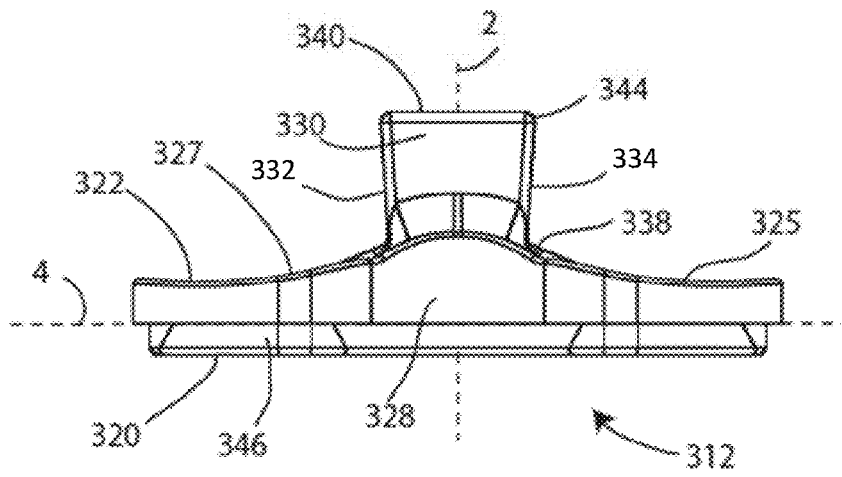

Fig. 12D

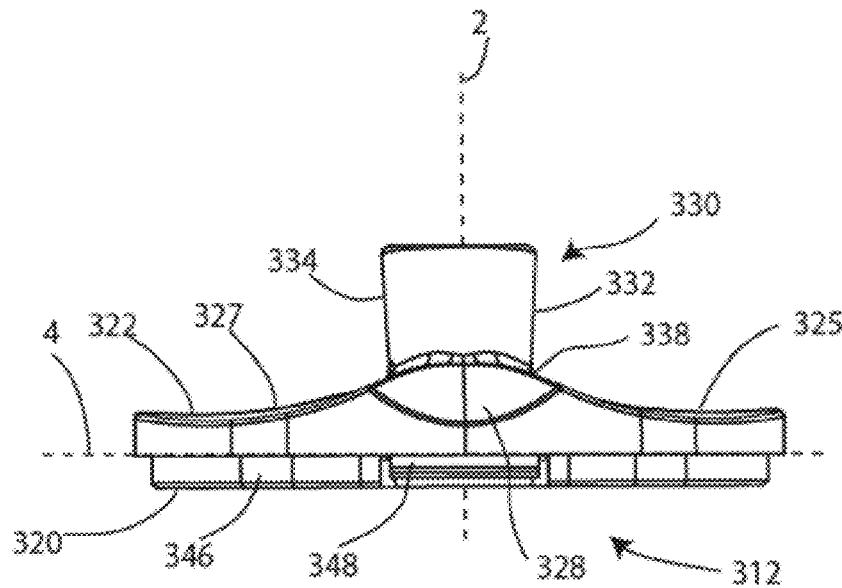

Fig. 12E

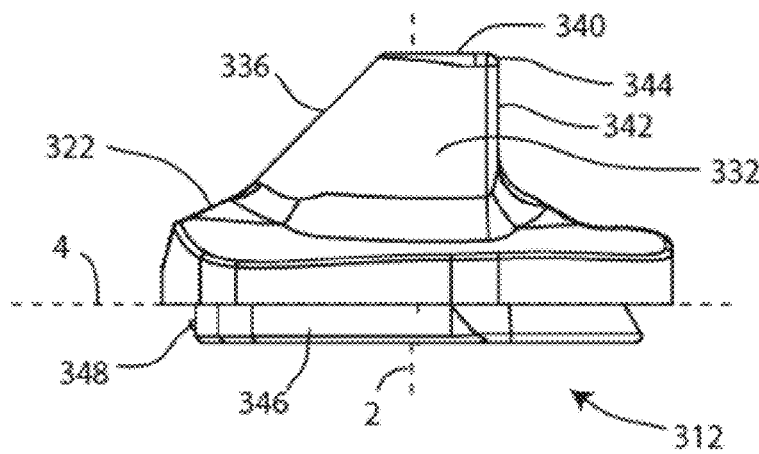

Fig. 12F

	Cruciate Retaining Insert	Posterior Stabilizing Insert	Constrained Condylar Knee Insert
Cruciate Retaining Femoral Component	X	X	X
Posterior Stabilizing Femoral Component	X	X	X

Fig. 13

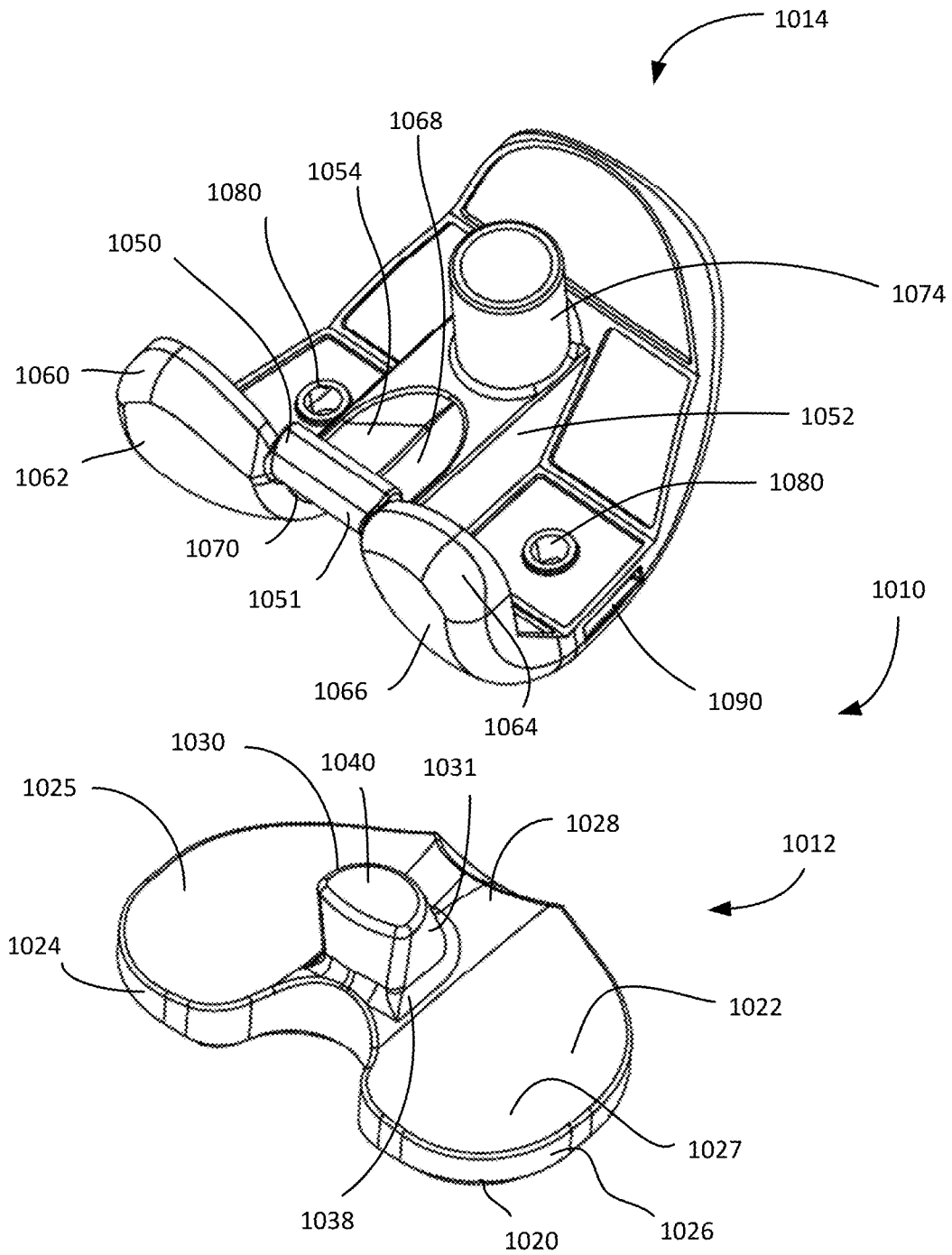

Fig. 14

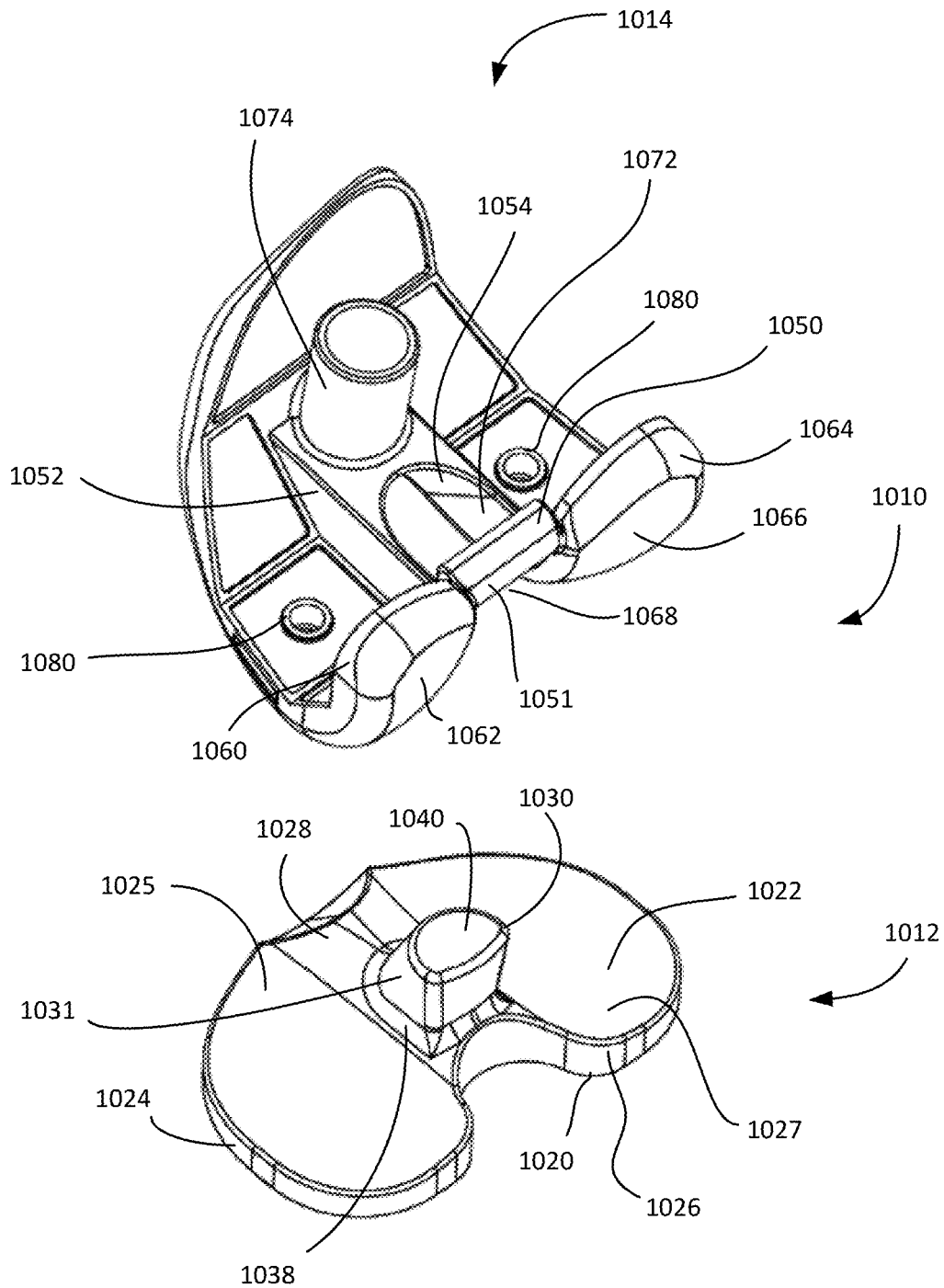

Fig. 15



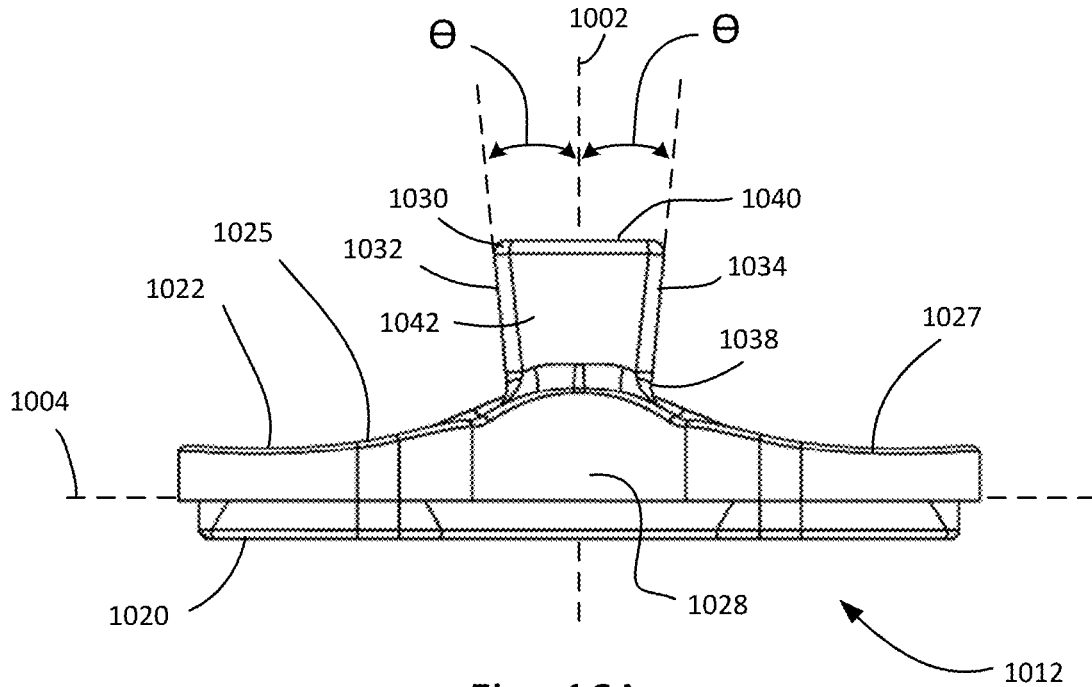

Fig. 16A

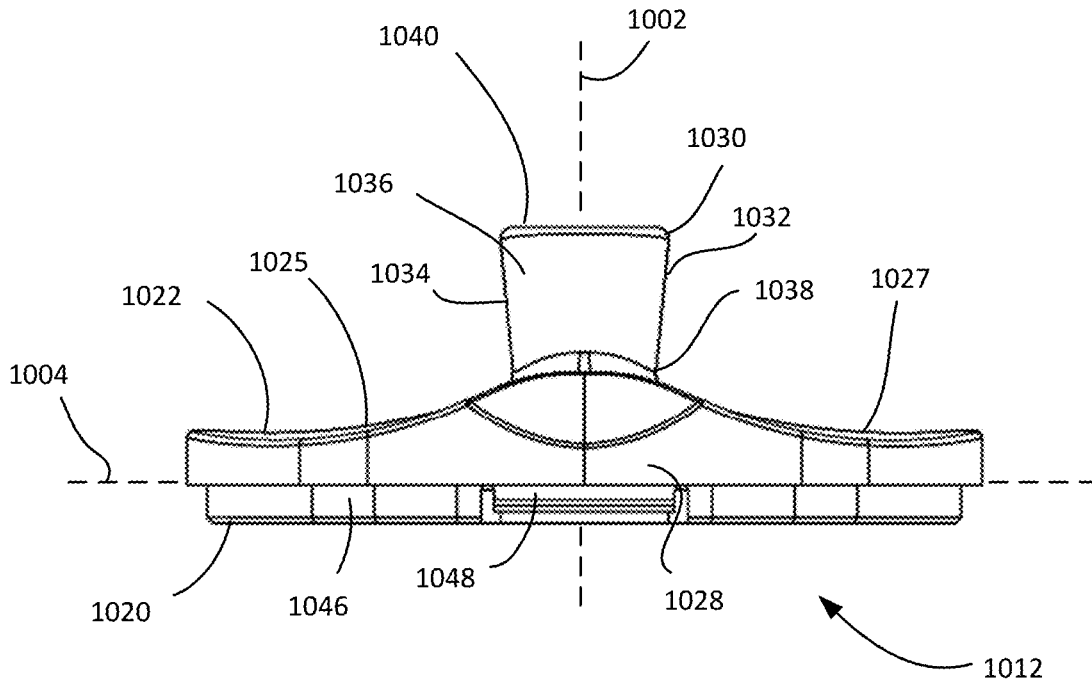
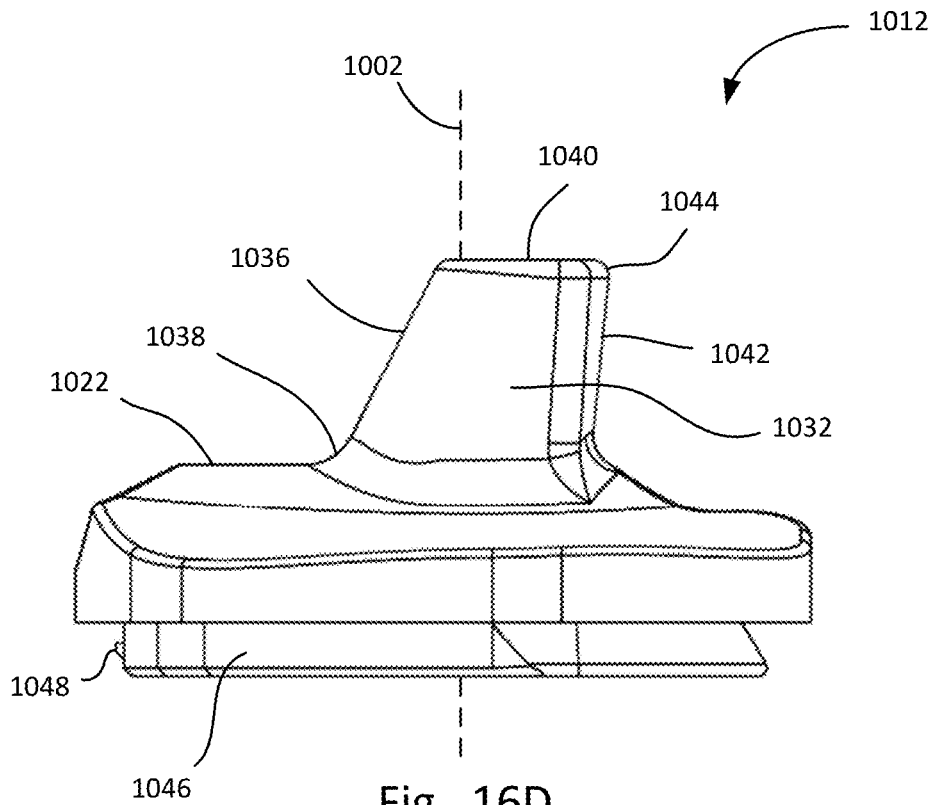
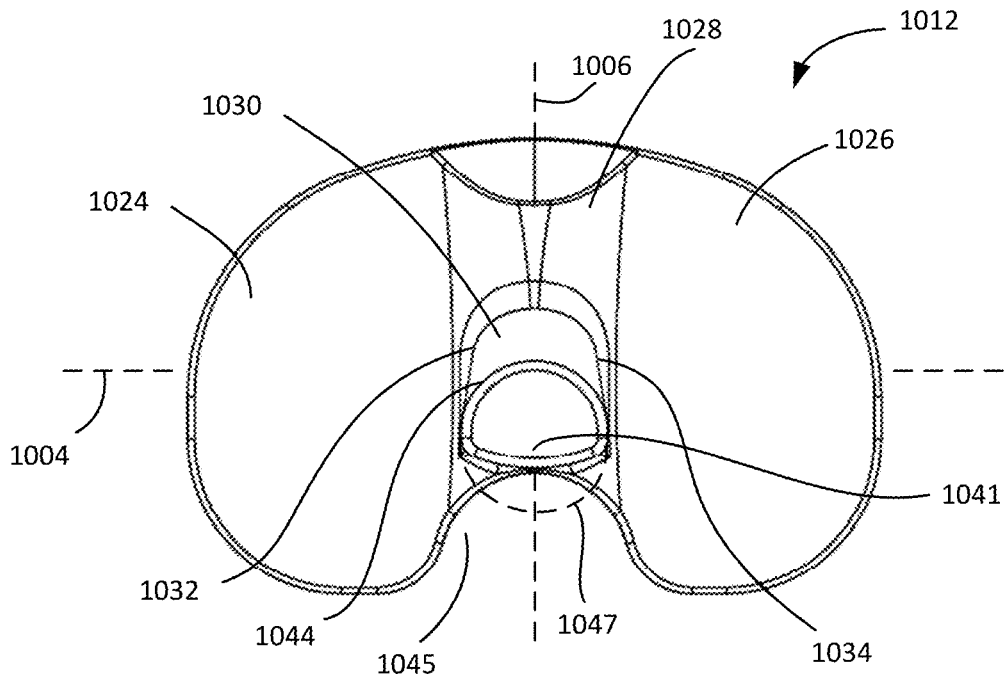

Fig. 16B



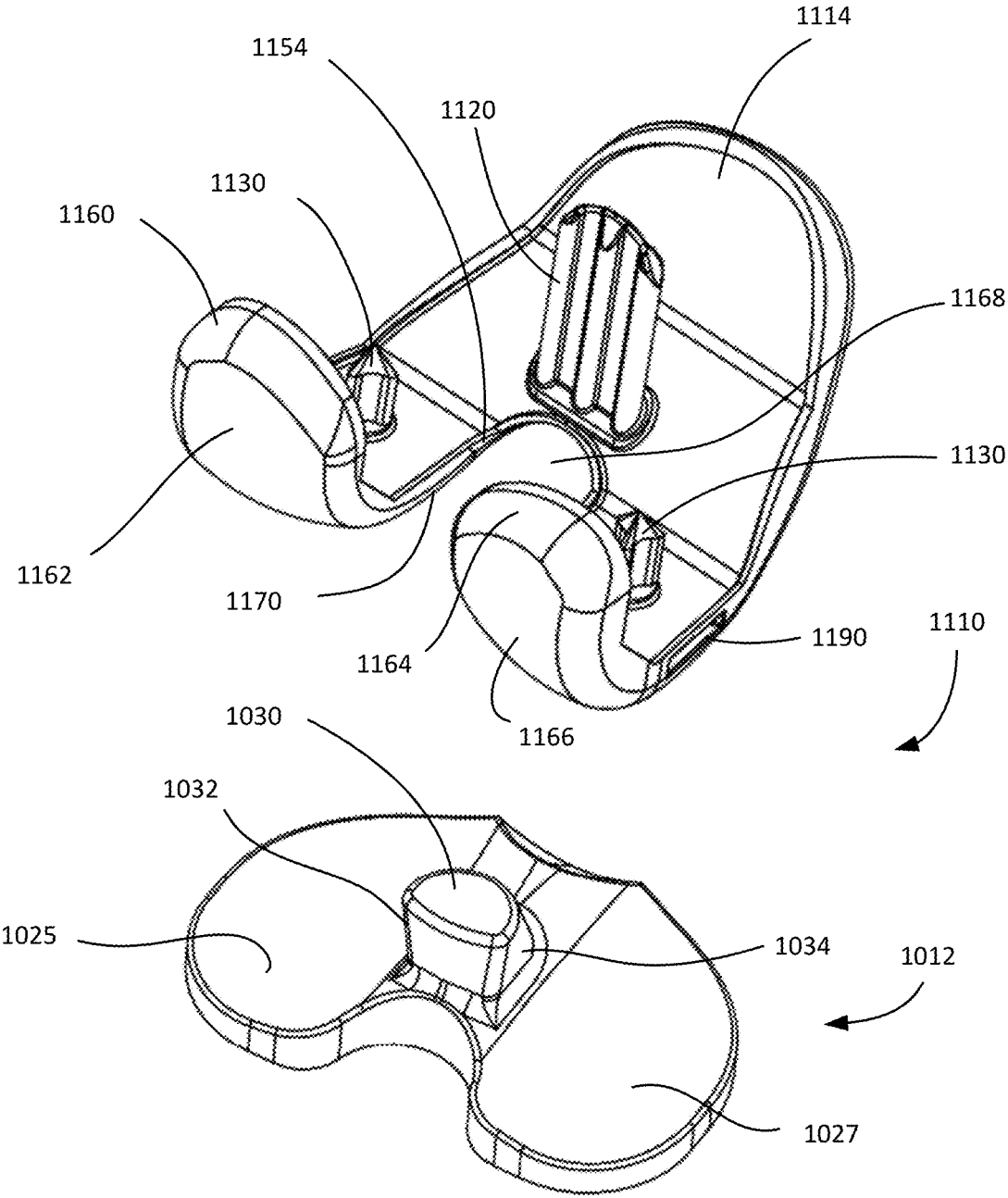

Fig. 17

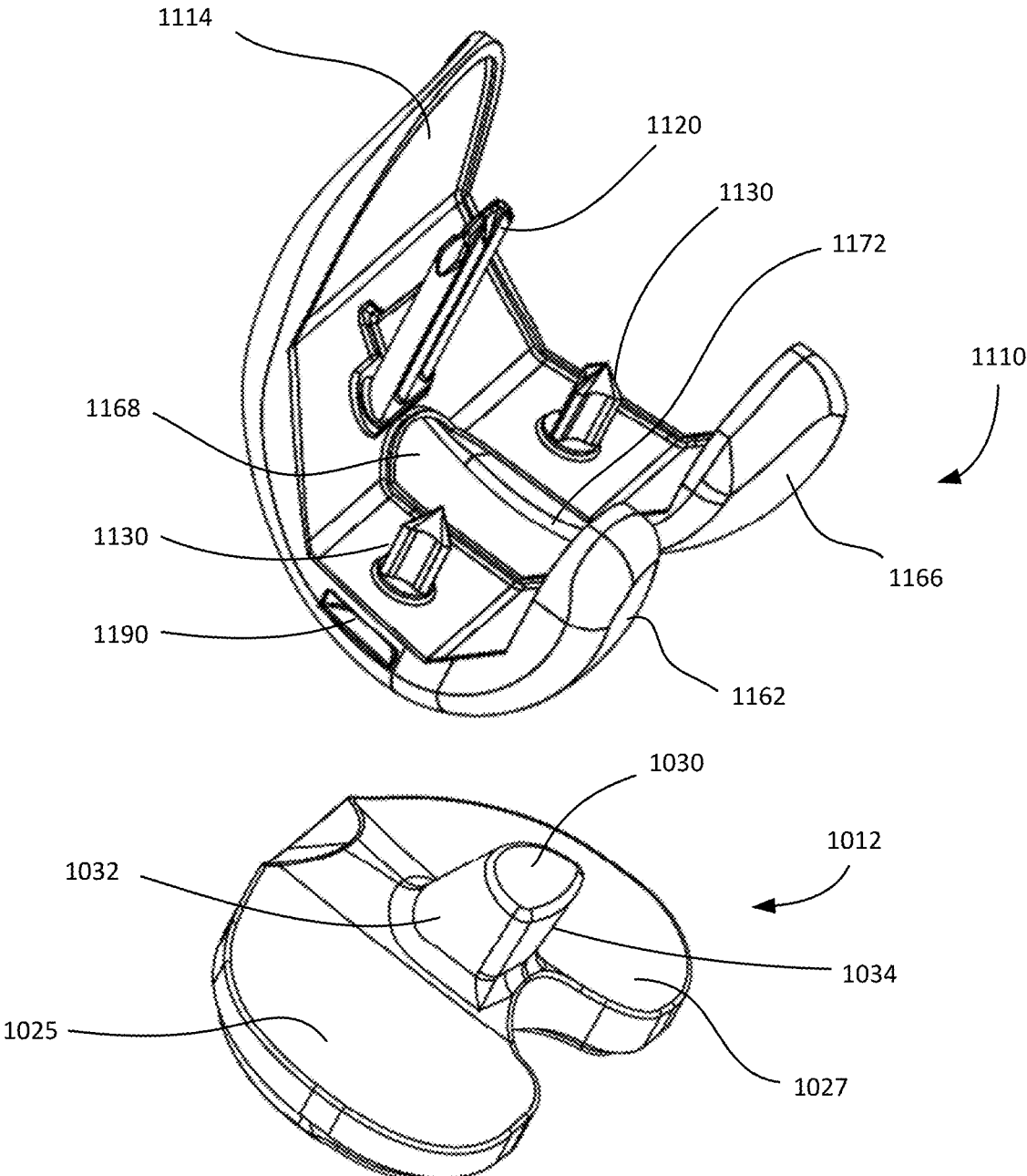

Fig. 18

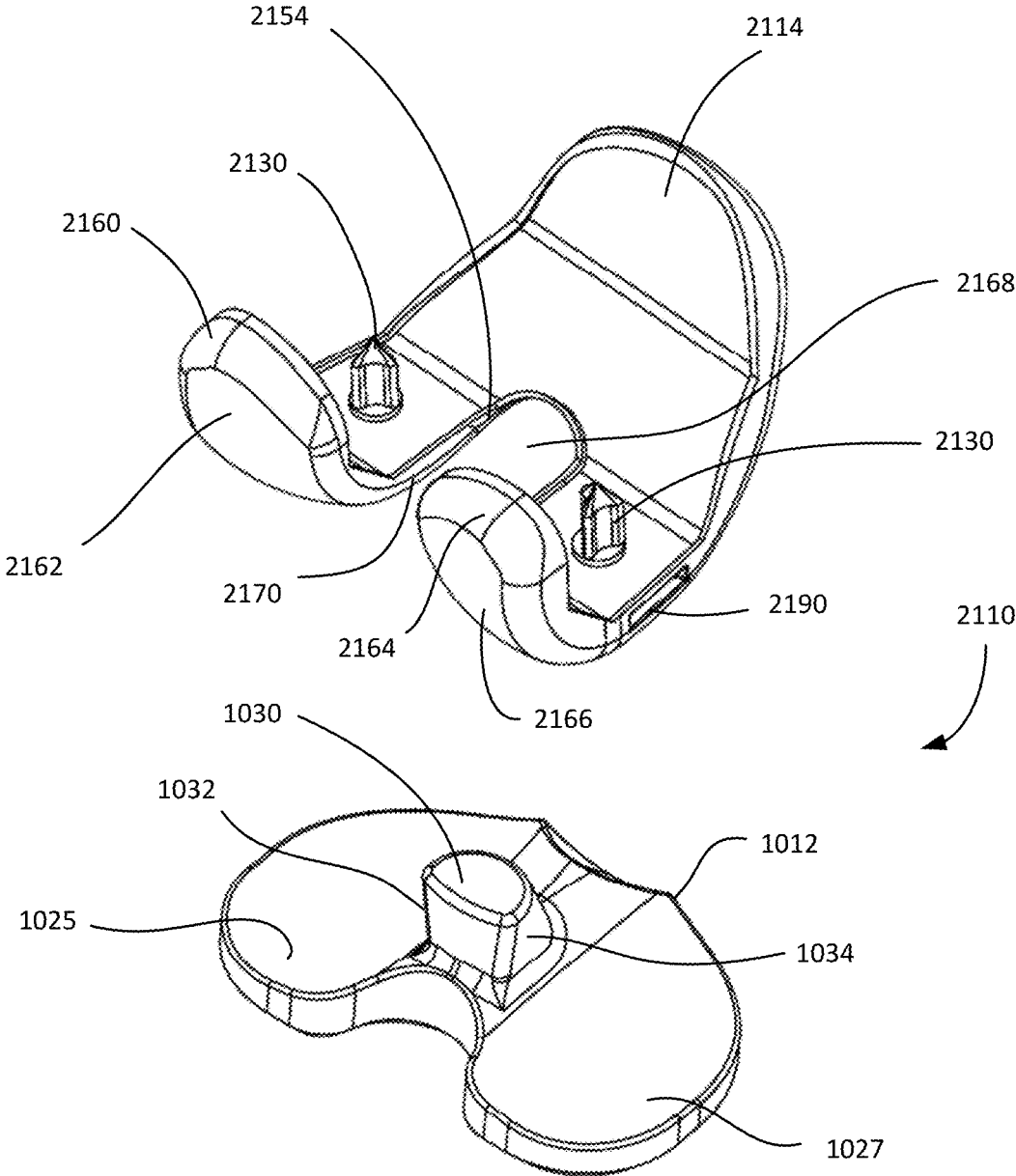

Fig. 19

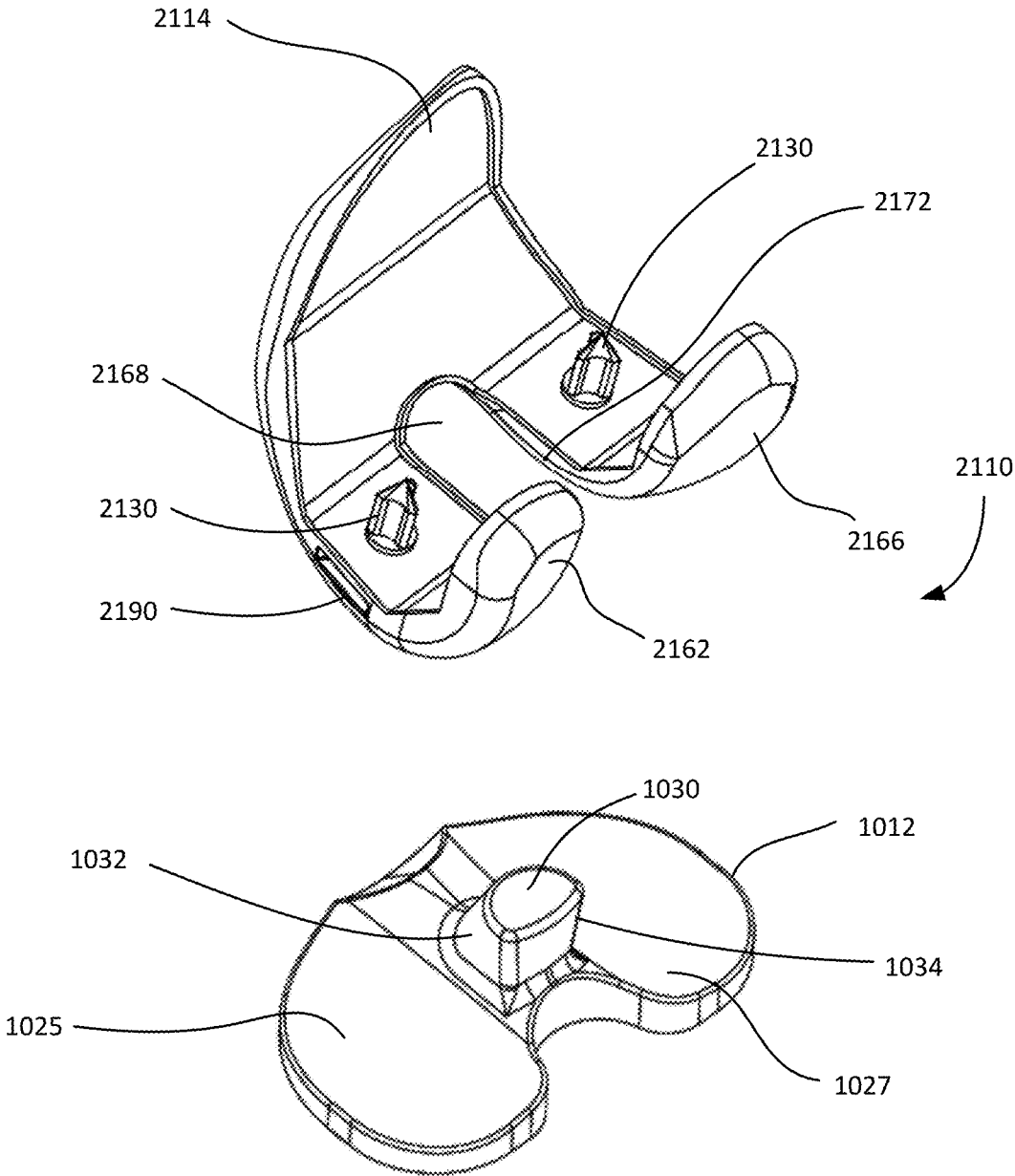

Fig. 20

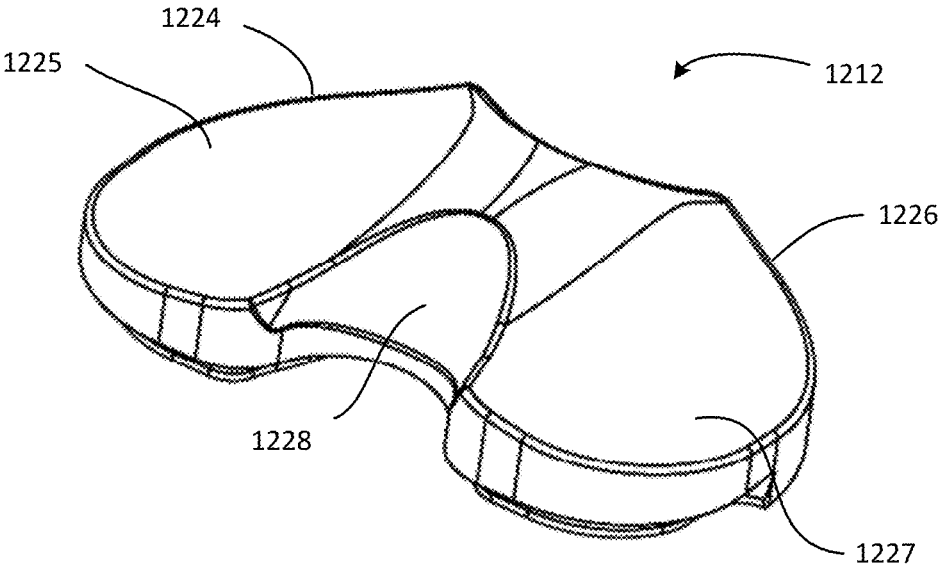

Fig. 21A

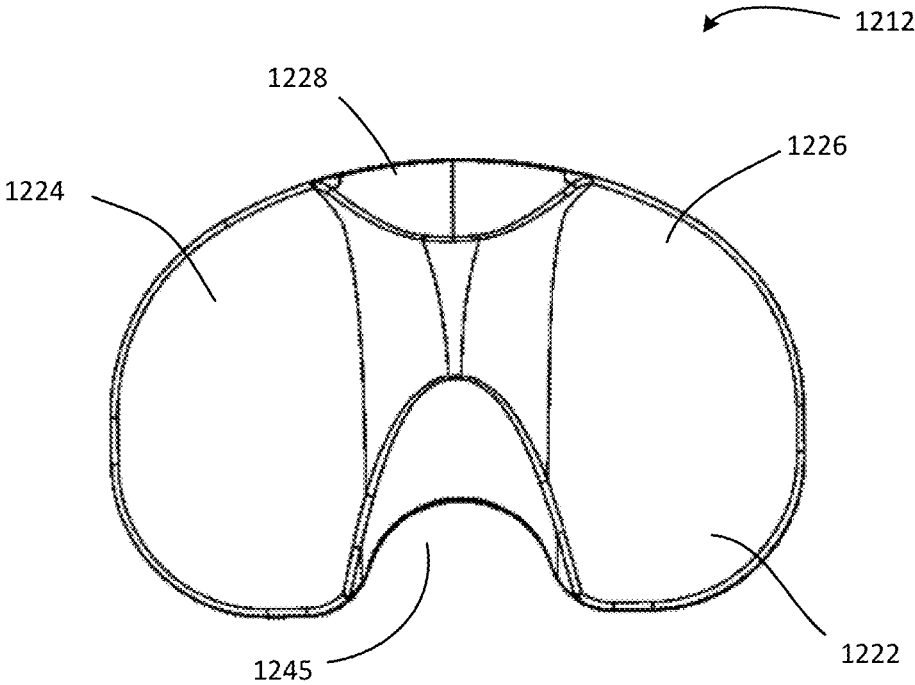

Fig. 21B

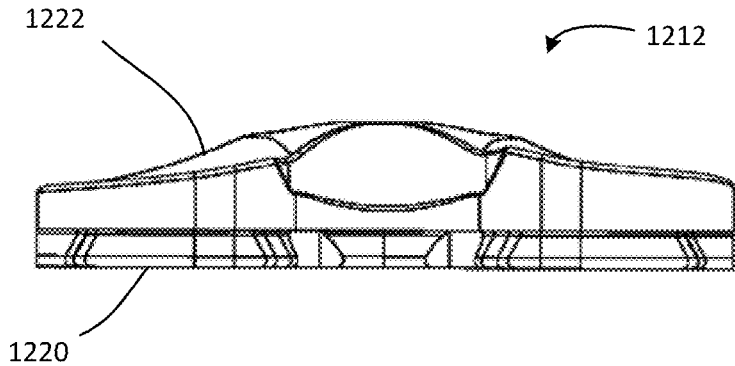

Fig. 21C

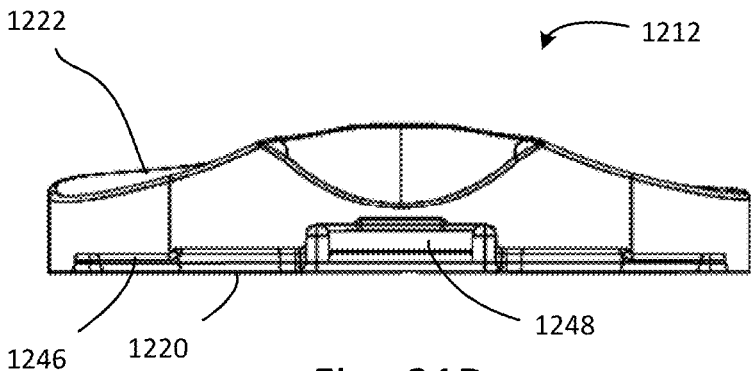

Fig. 21D

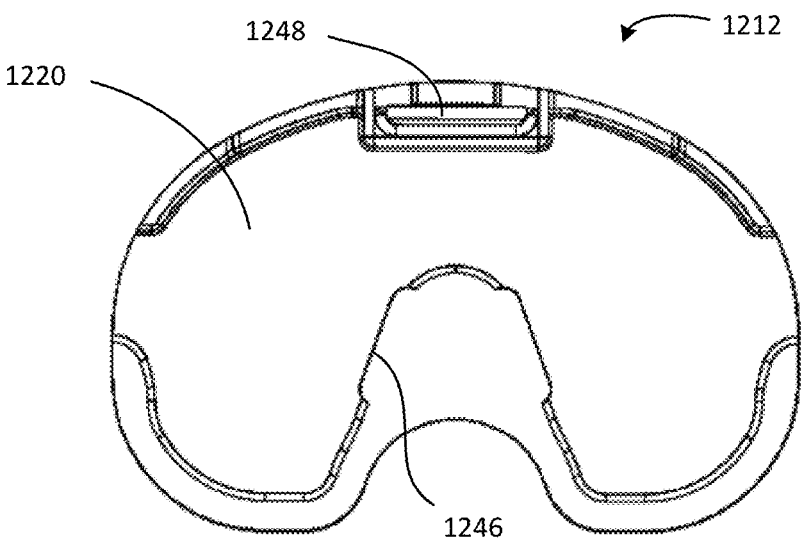

Fig. 21E



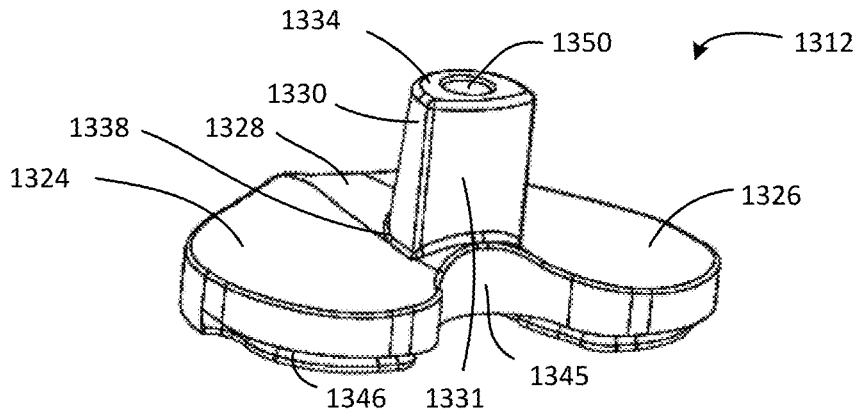

Fig. 22A

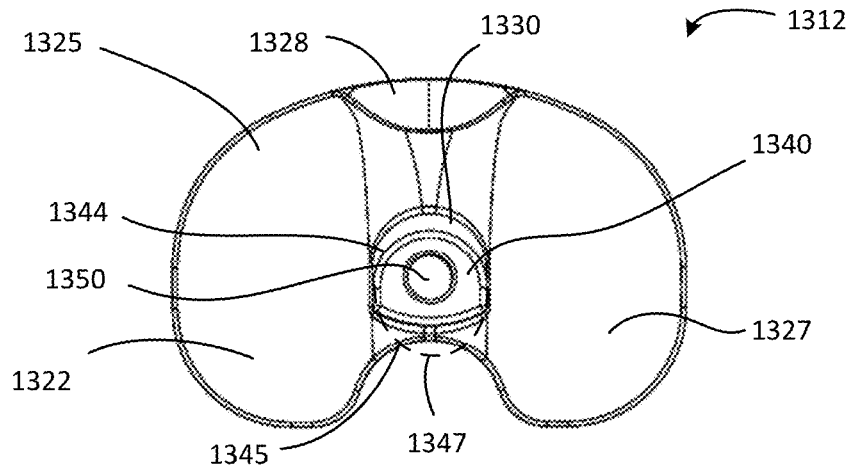

Fig. 22B

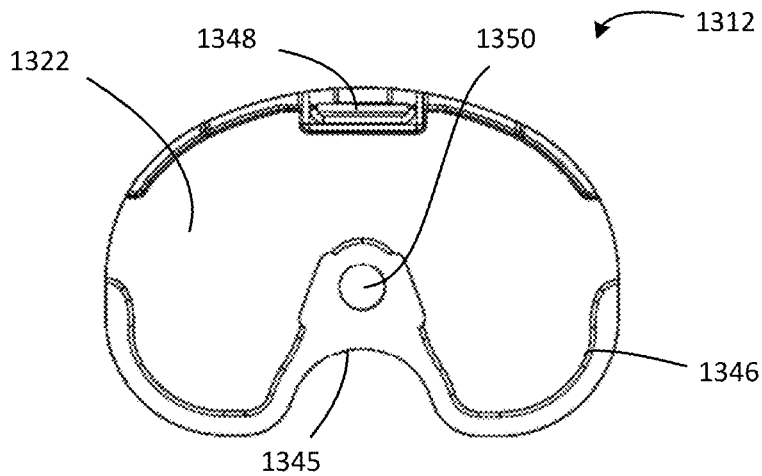

Fig. 22C

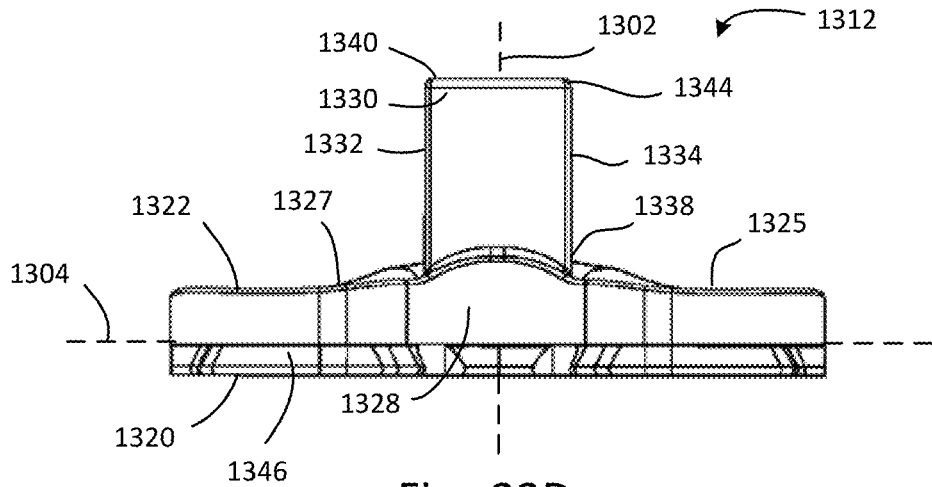

Fig. 22D

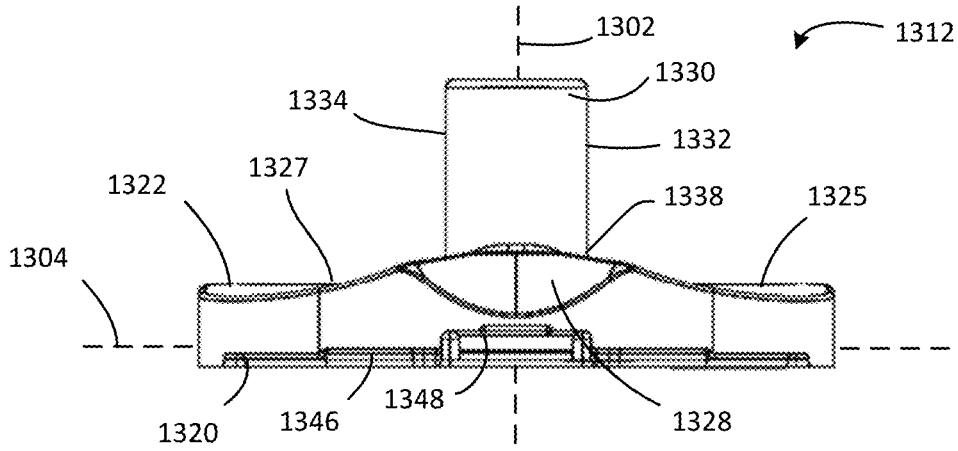

Fig. 22E

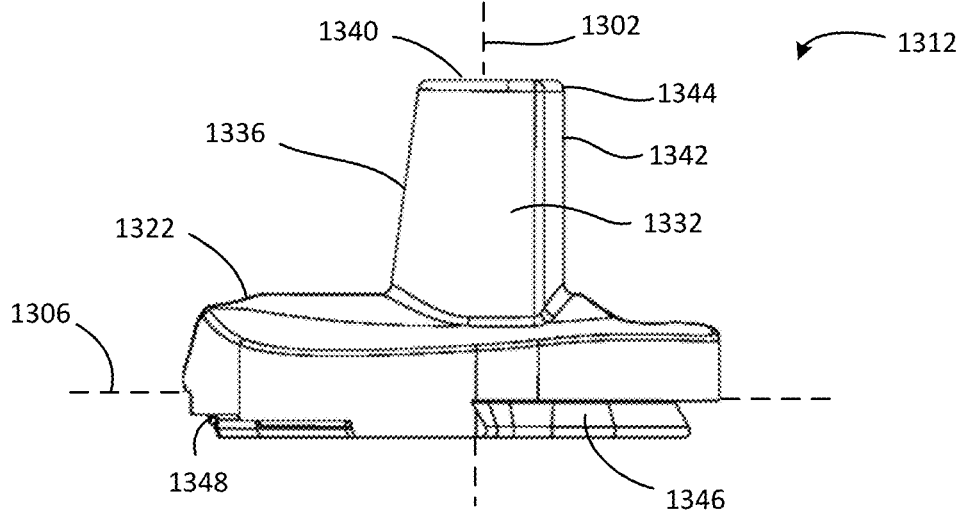

Fig. 22F

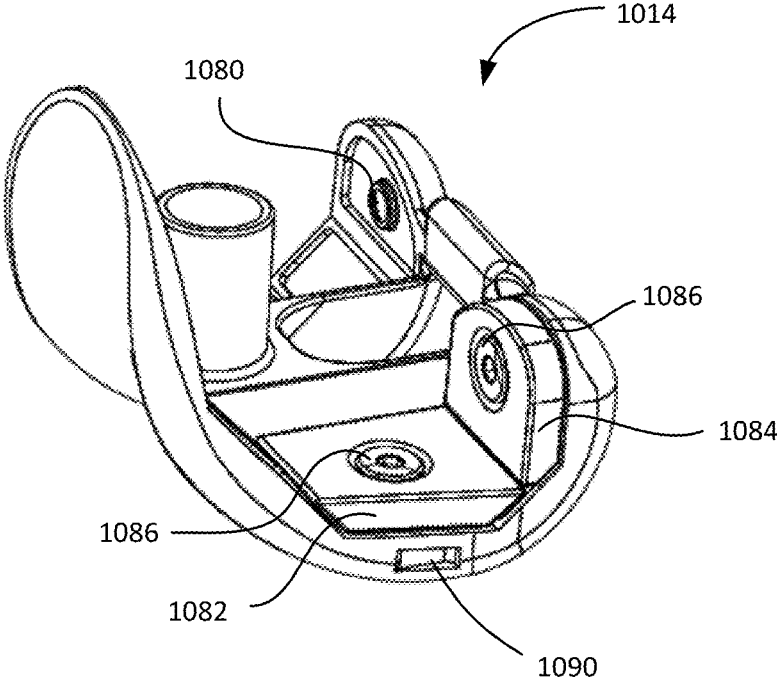

Fig. 23A

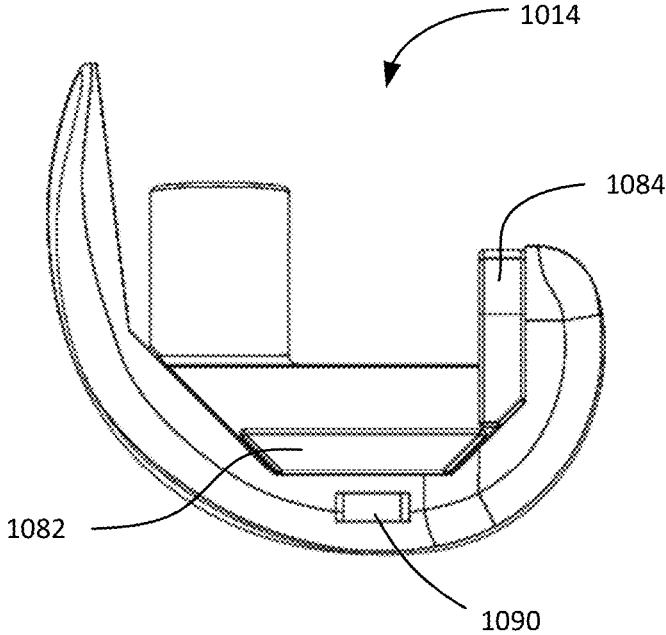

Fig. 23B

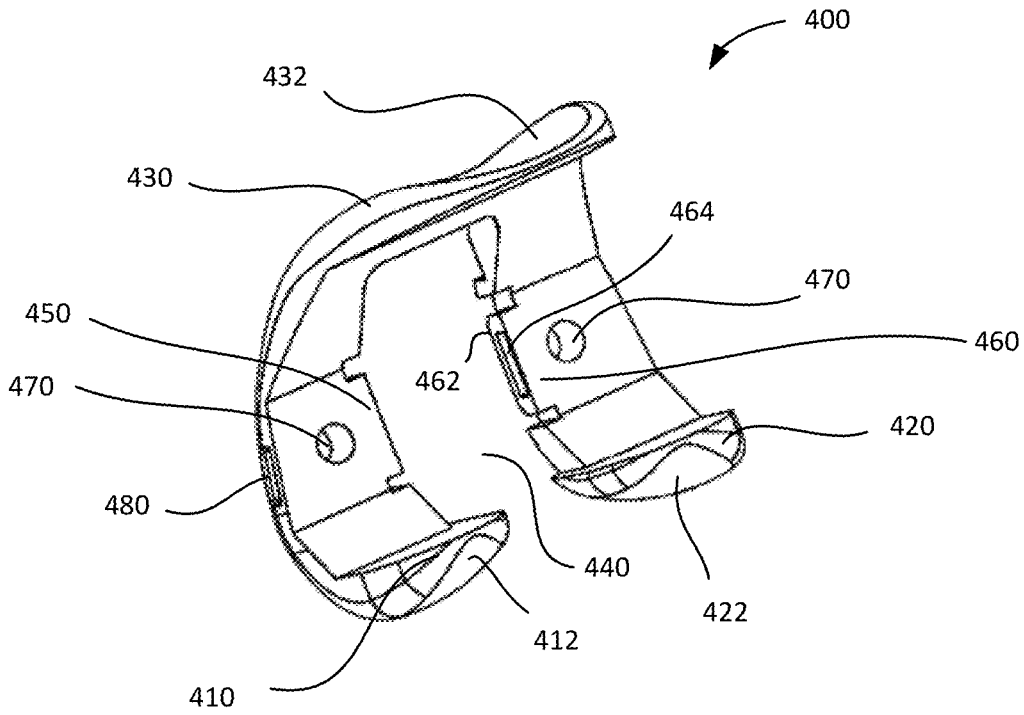

Fig. 24A

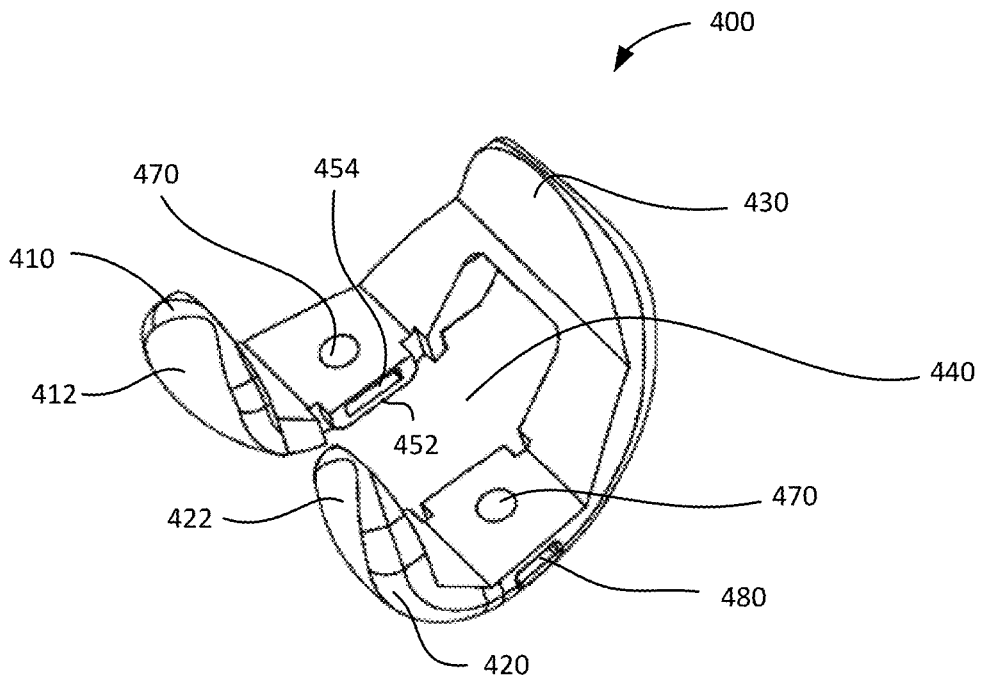

Fig. 24B

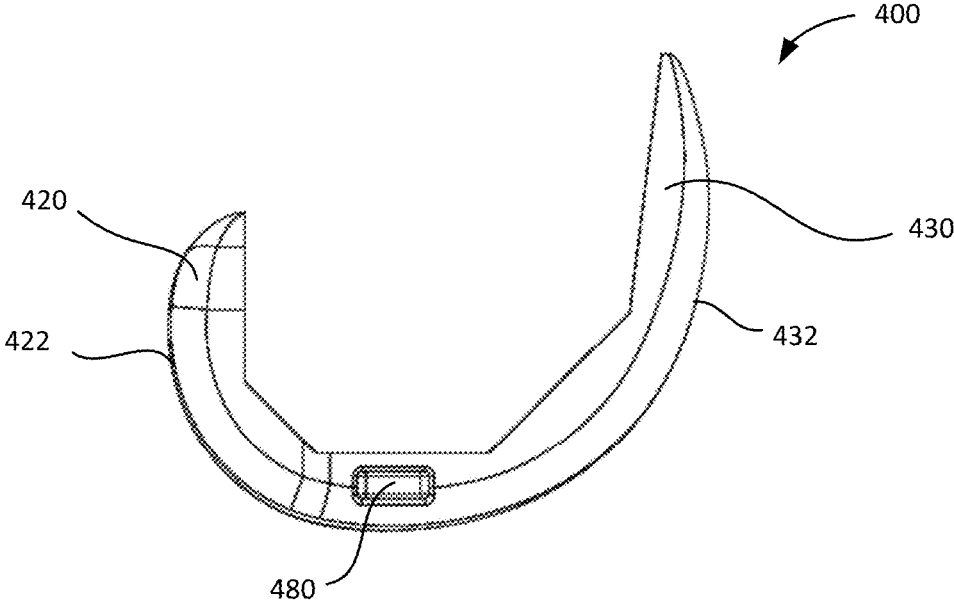

Fig. 24C

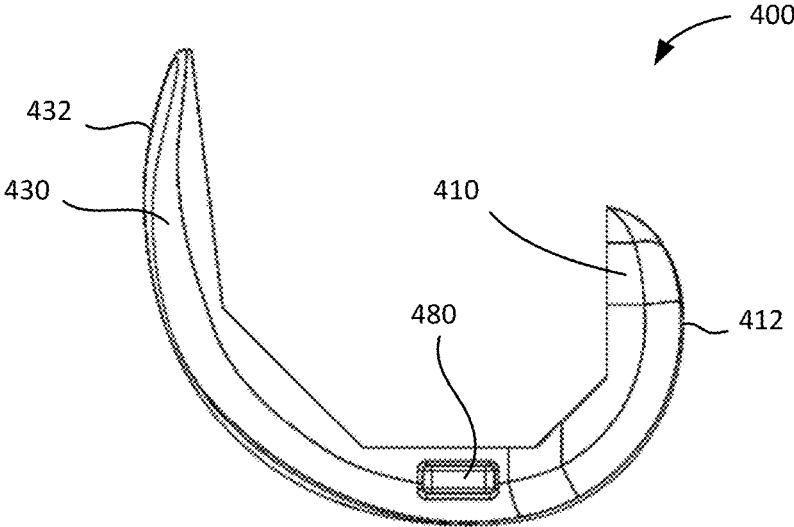

Fig. 24D

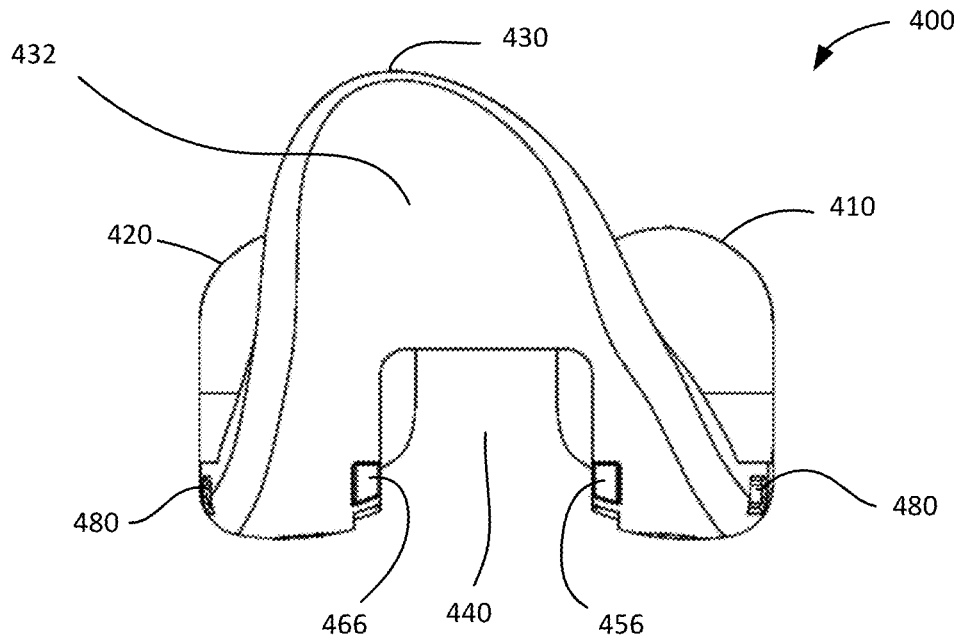

Fig. 24E

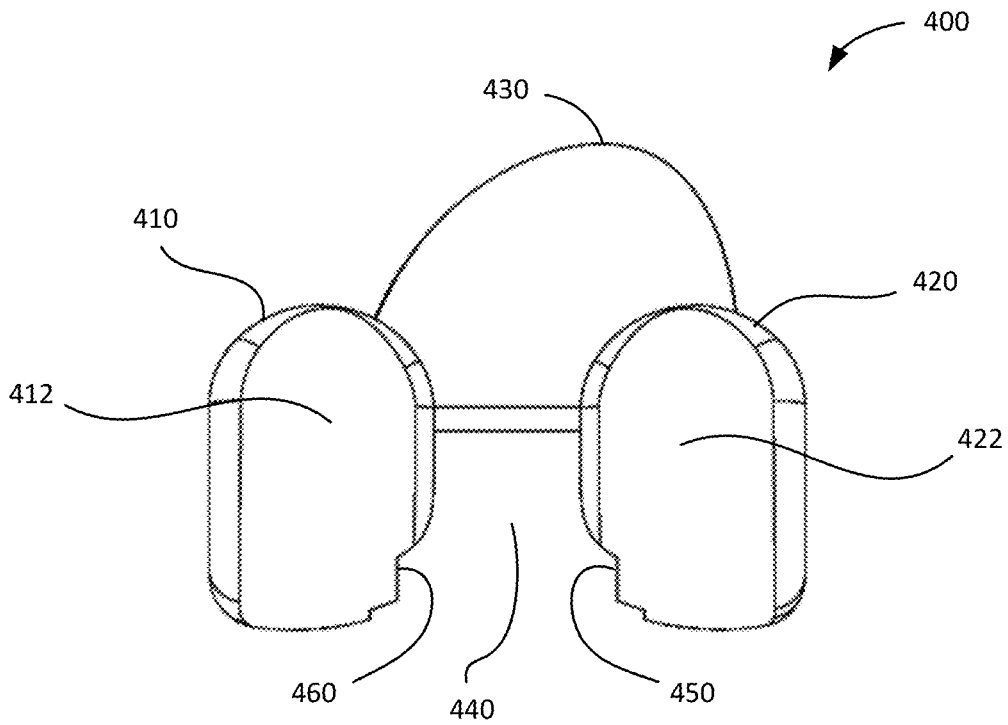

Fig. 24F

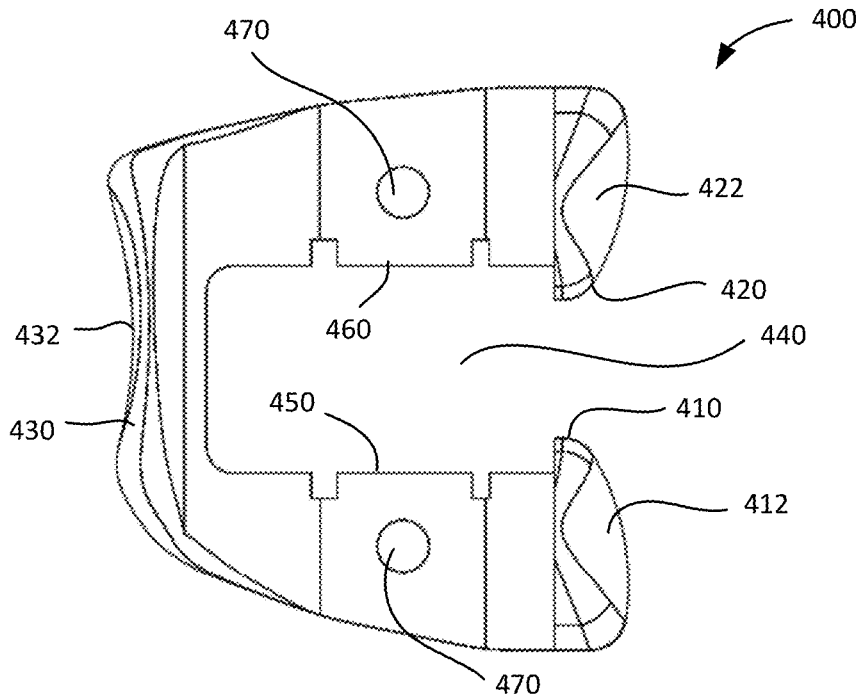

Fig. 24G

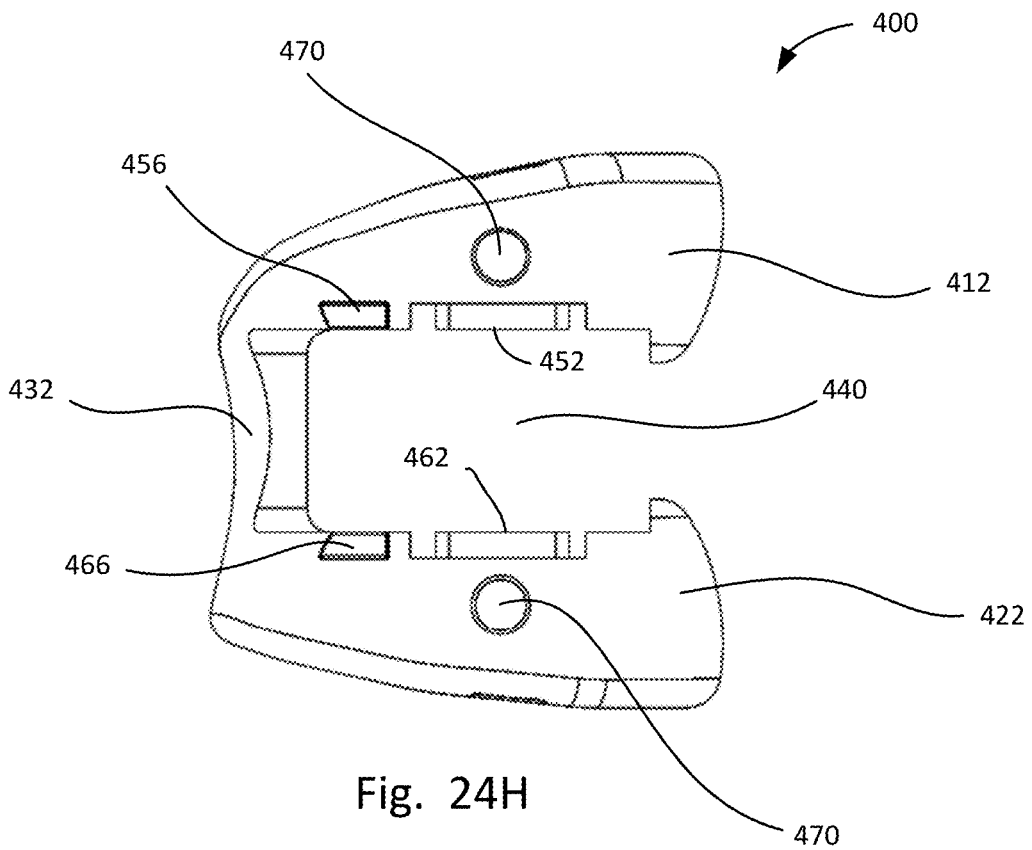

Fig. 24H

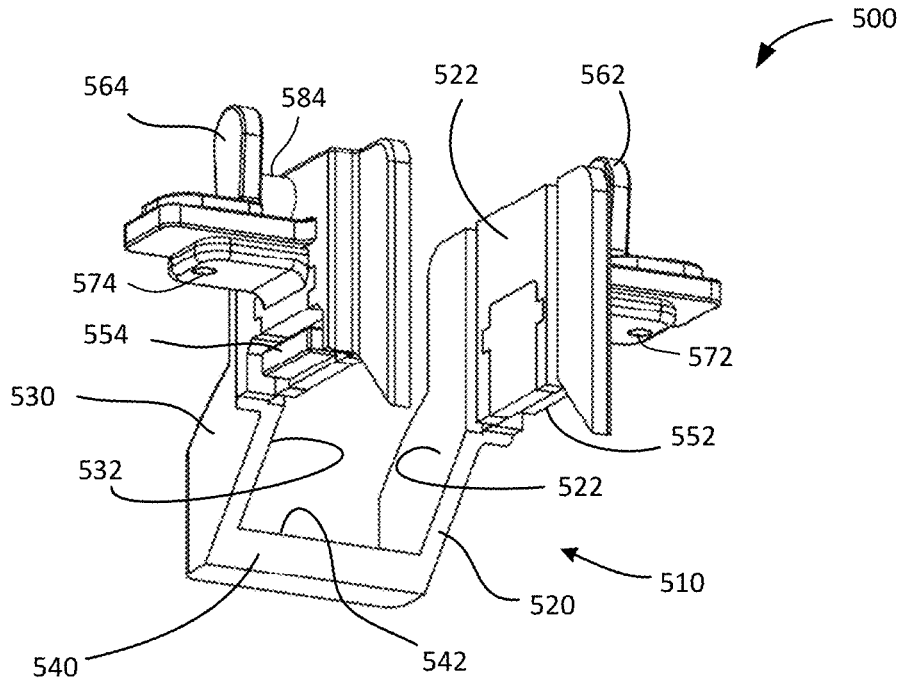

Fig. 25A

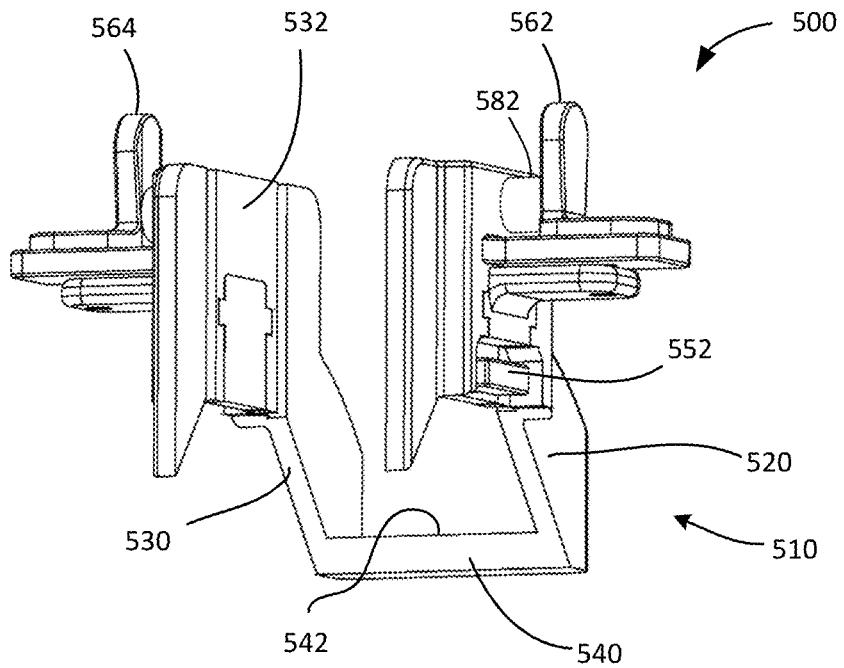

Fig. 25B



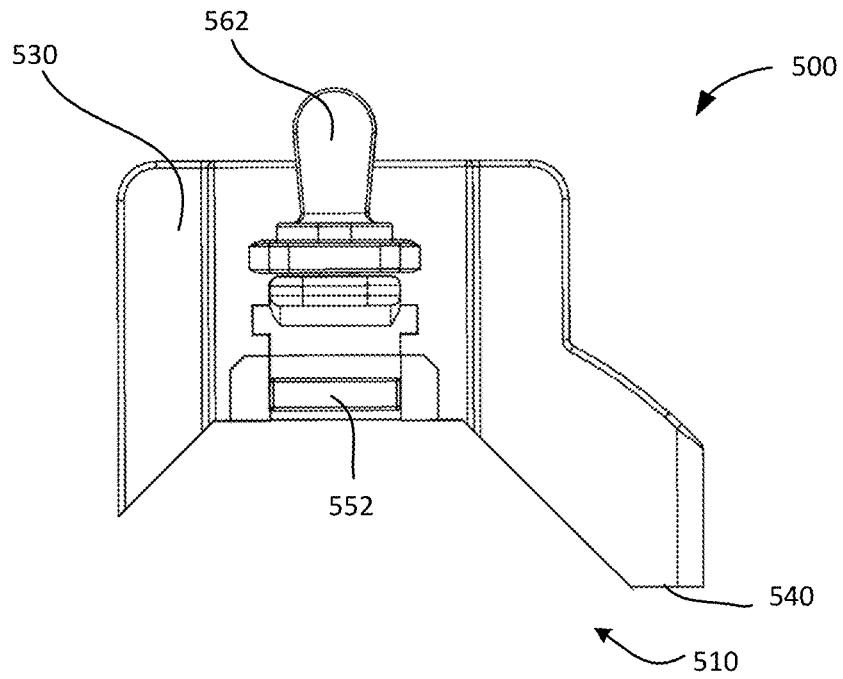

Fig. 25C

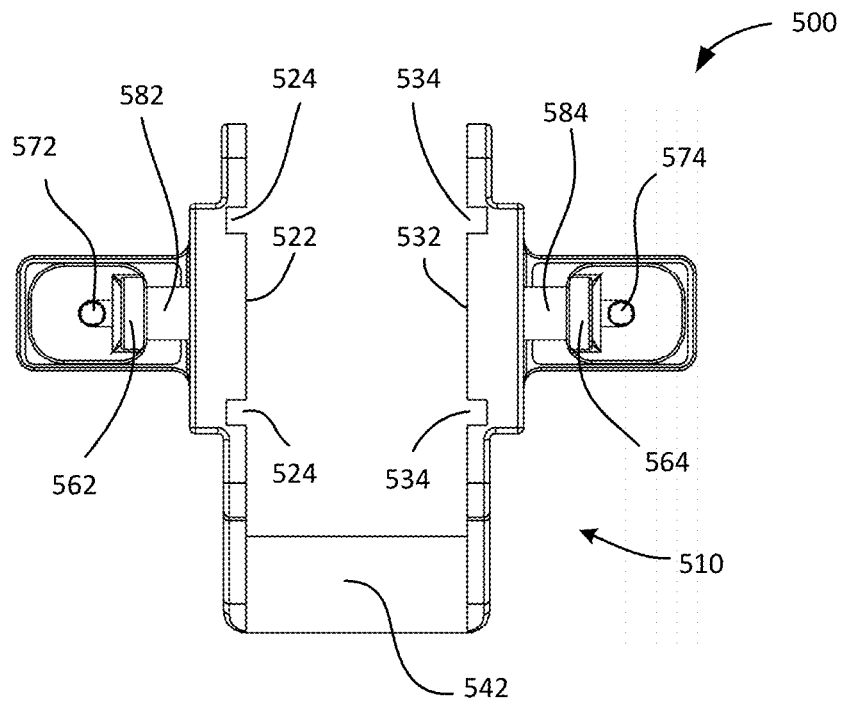

Fig. 25D

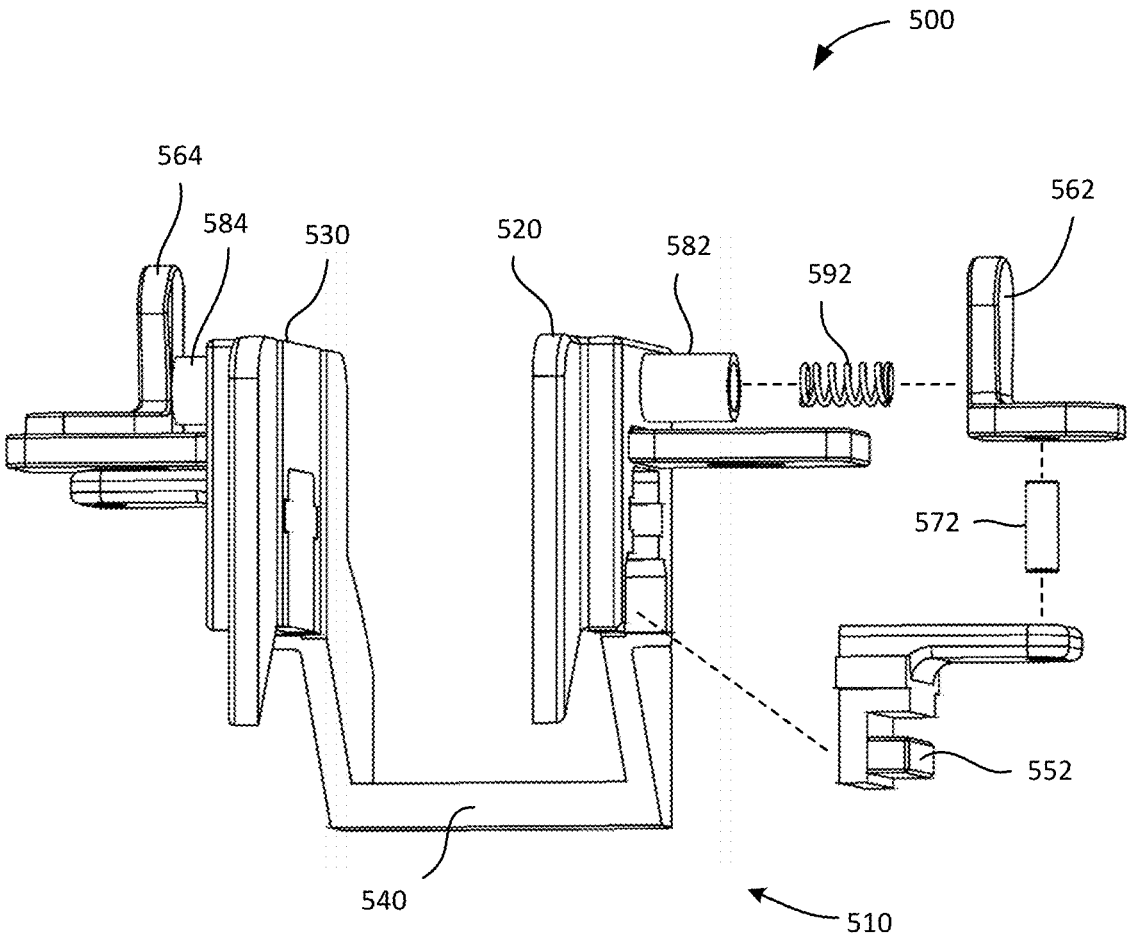

Fig. 26

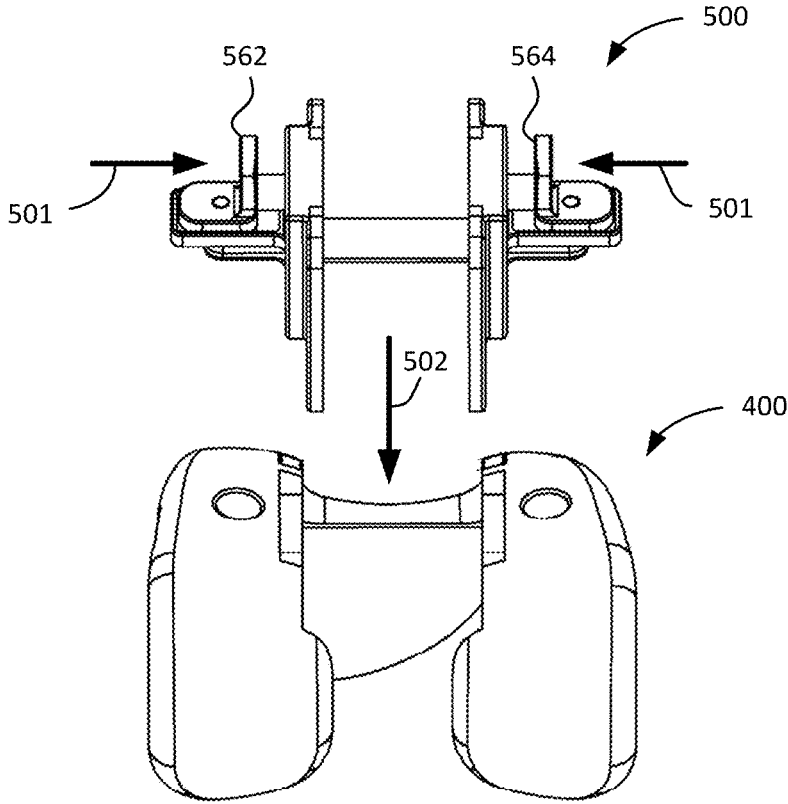

Fig. 27A

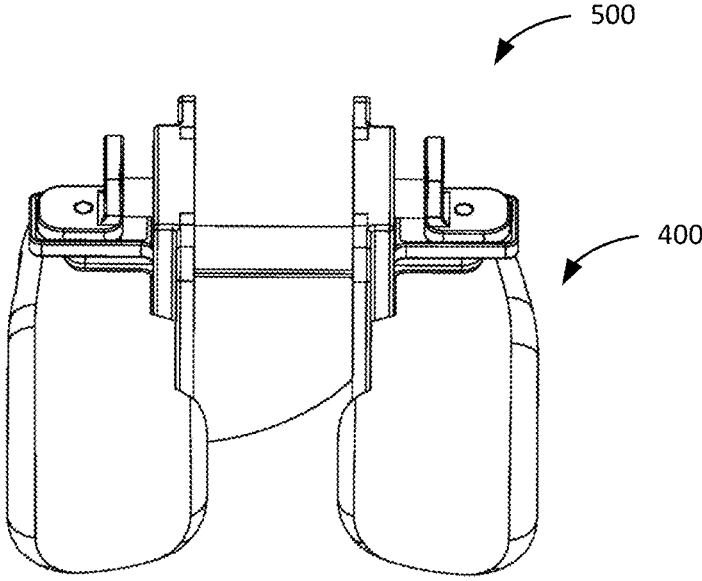

Fig. 27B

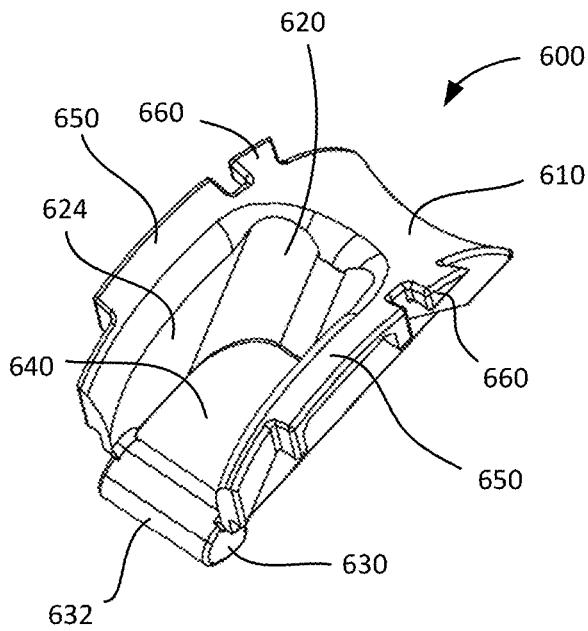

Fig. 28A

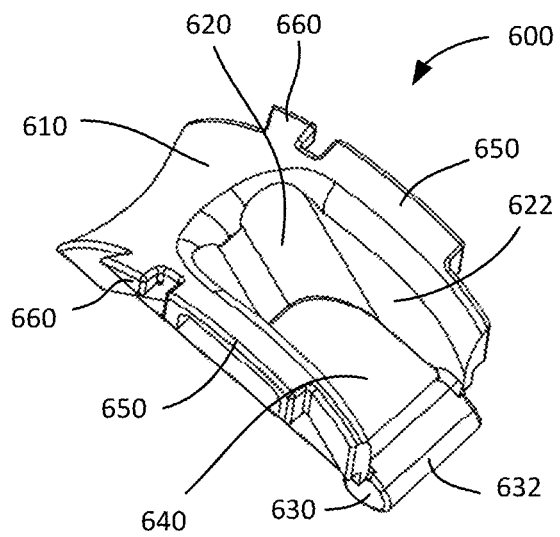

Fig. 28B

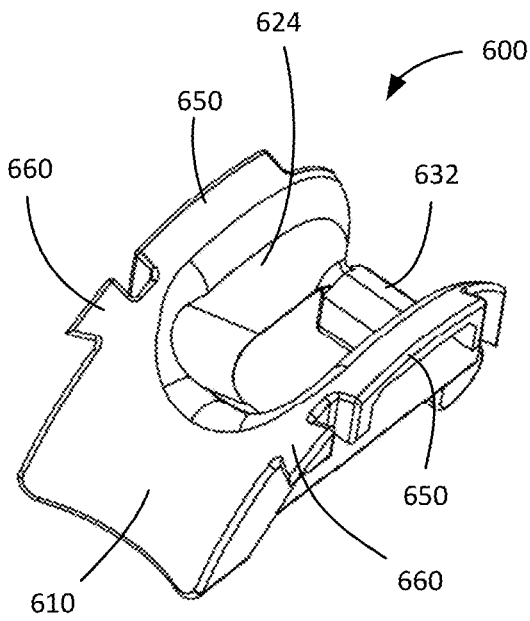

Fig. 28C

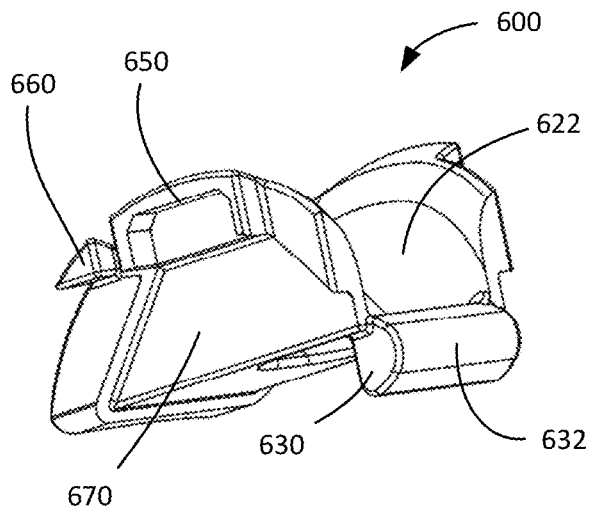

Fig. 28D

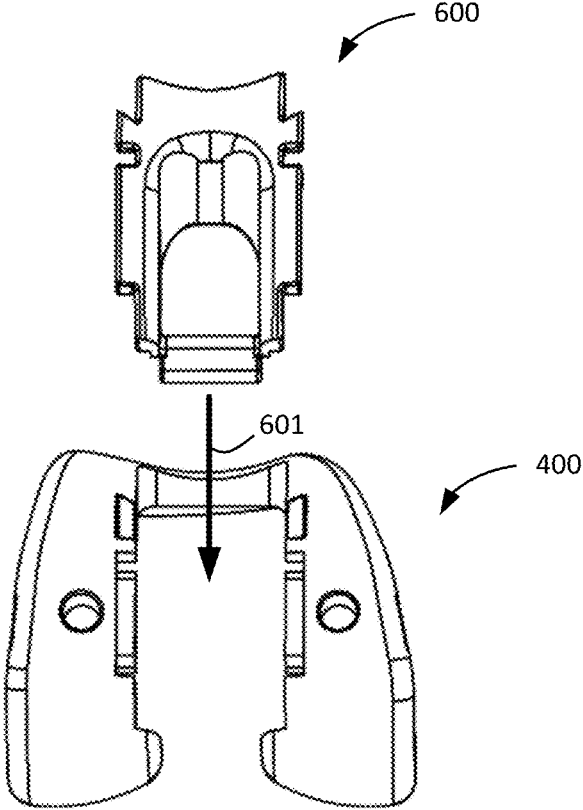

Fig. 29A

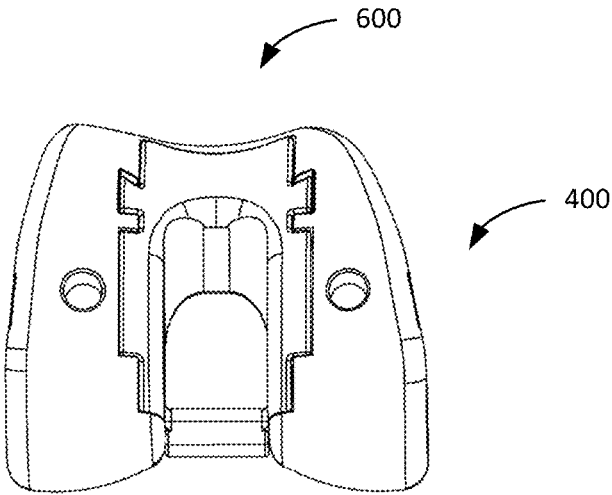

Fig. 29B

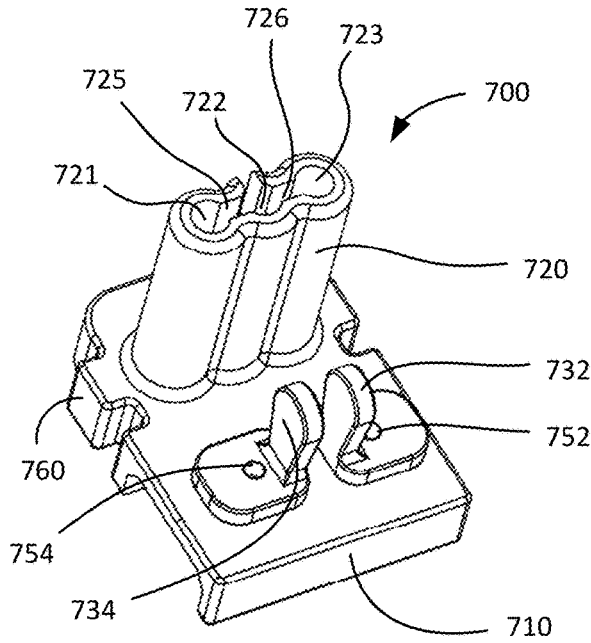

Fig. 30A

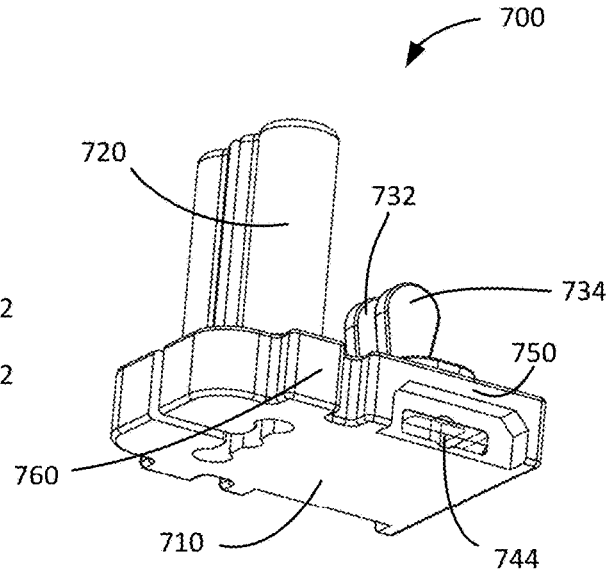

Fig. 30B

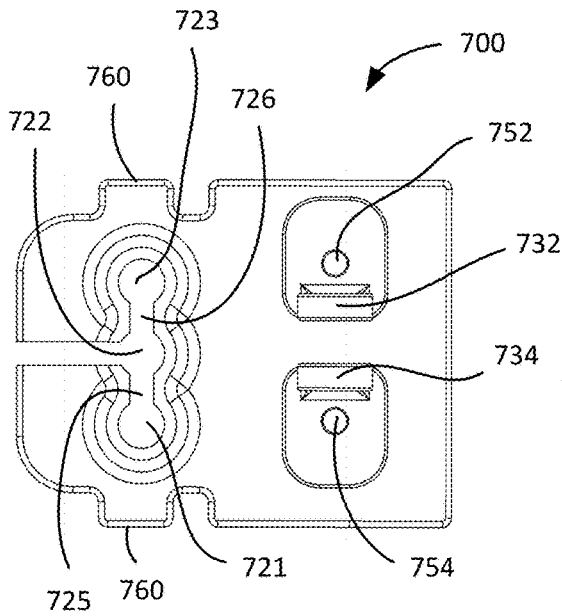

Fig. 30C

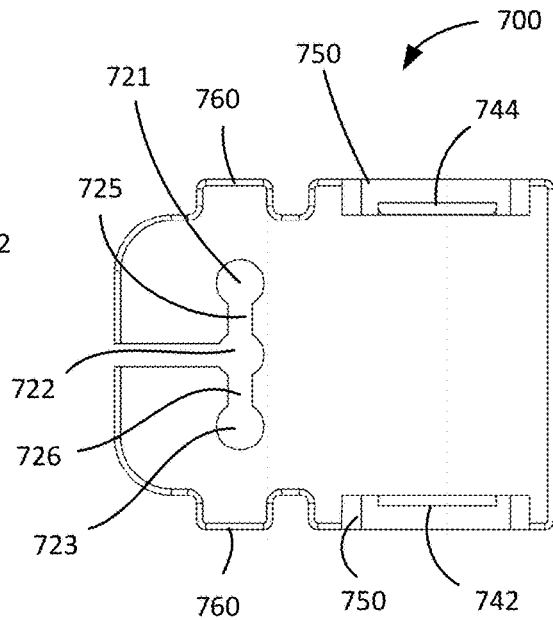

Fig. 30D

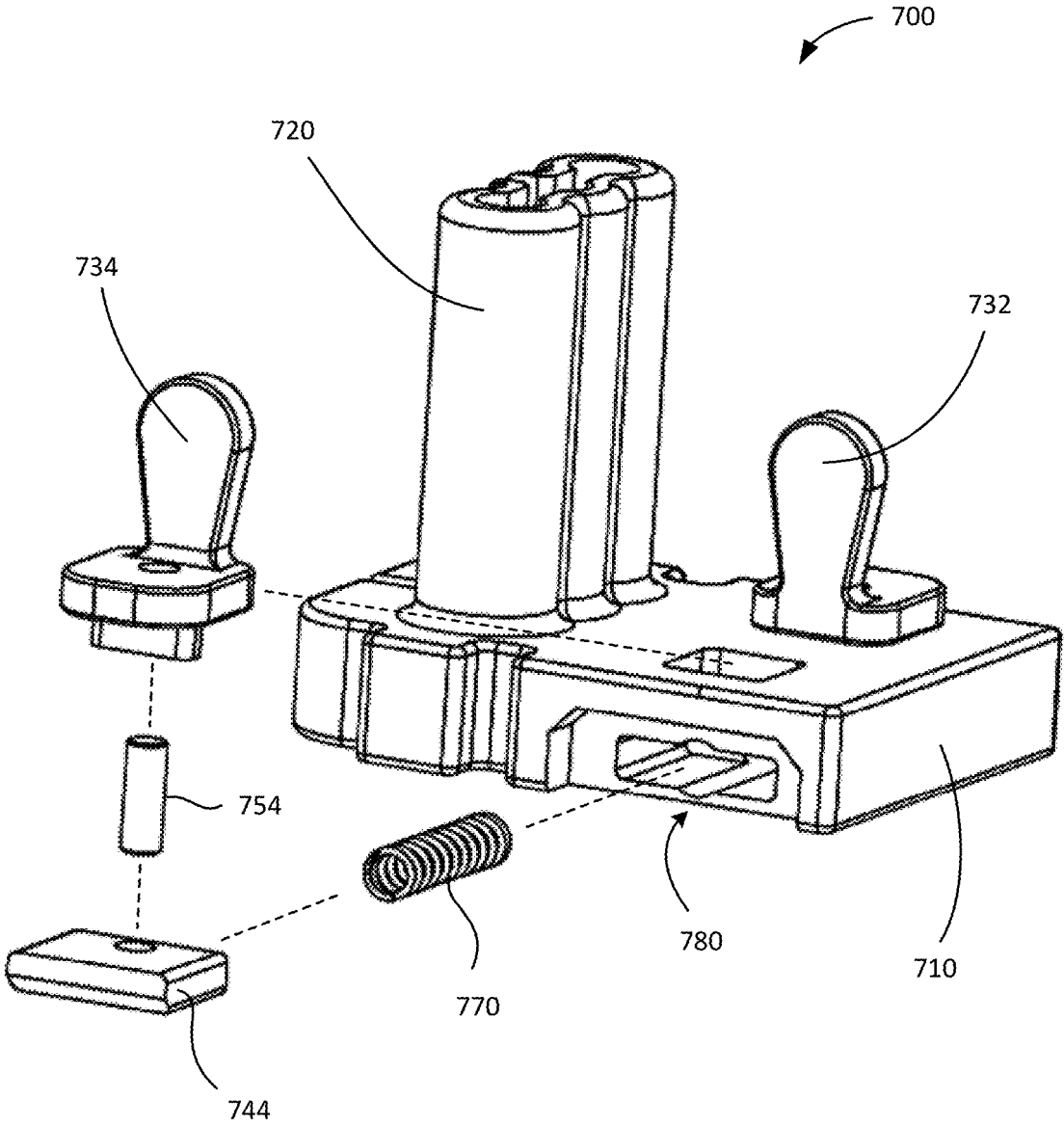

Fig. 31

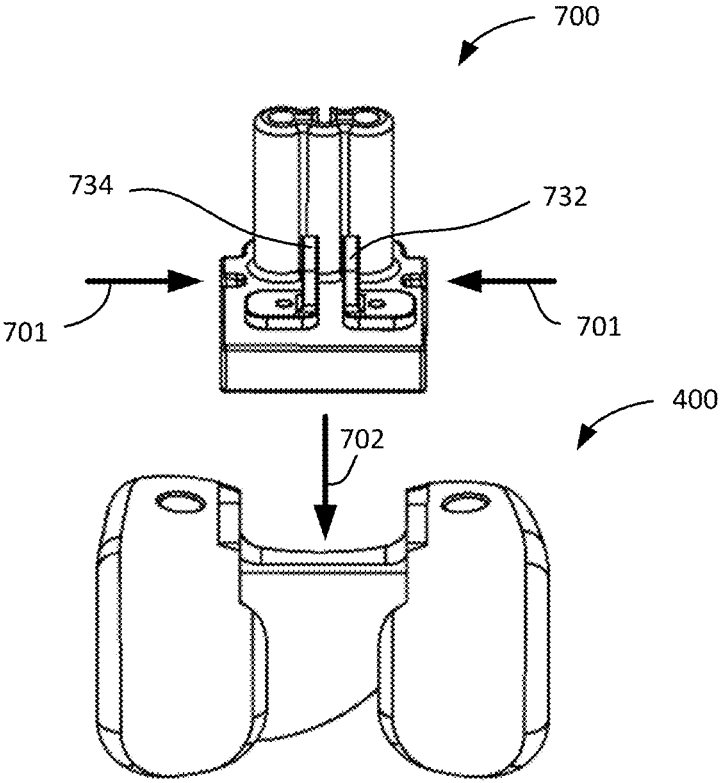

Fig. 32A

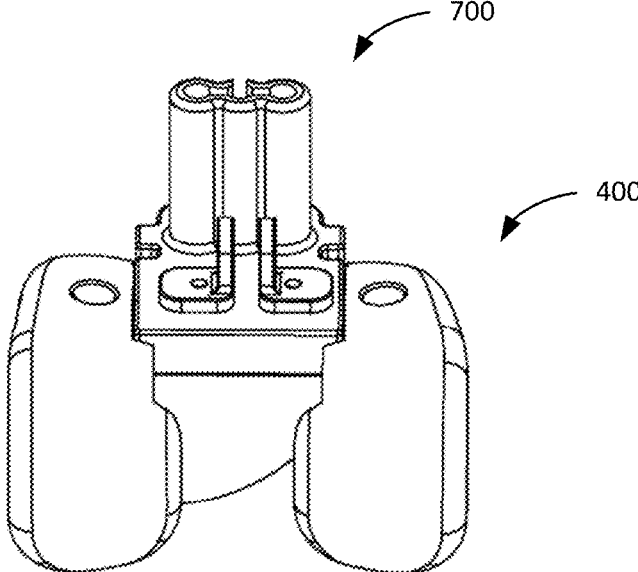

Fig. 32B



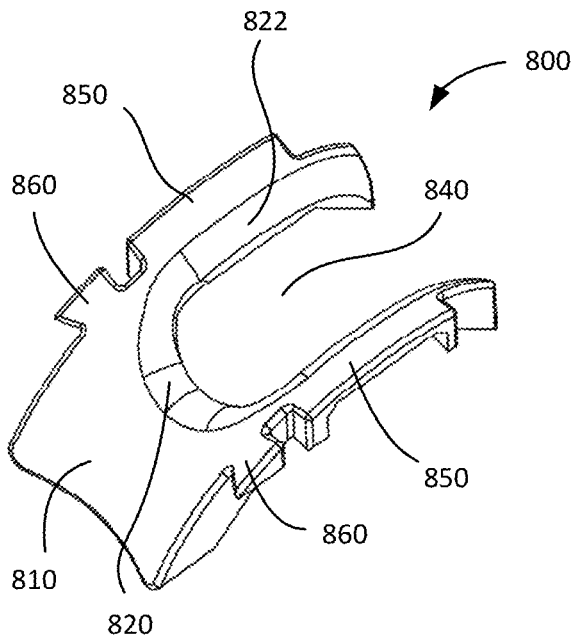

Fig. 33A

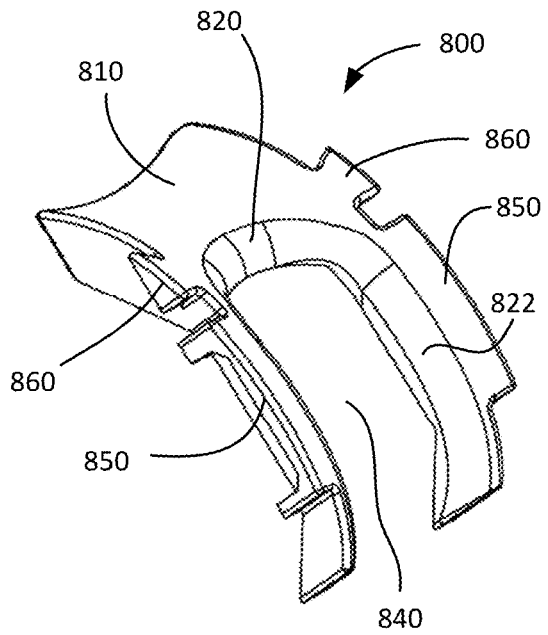

Fig. 33B

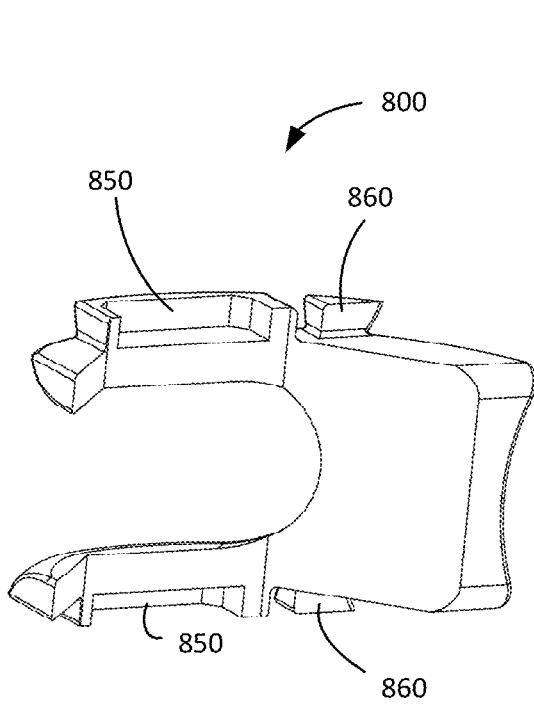

Fig. 33C

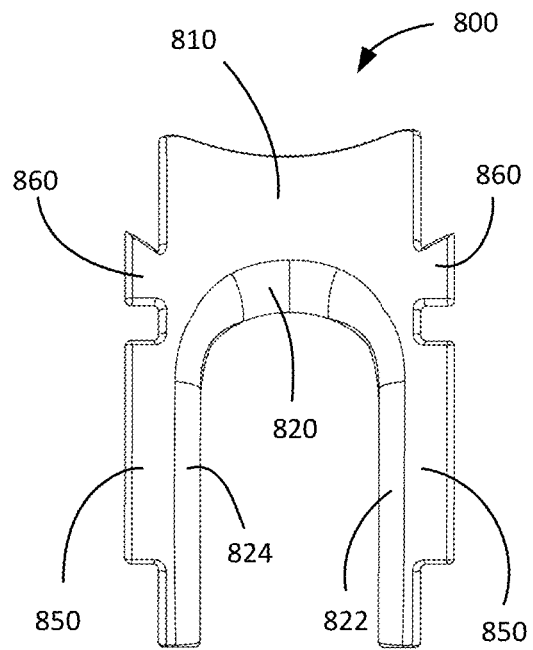

Fig. 33D

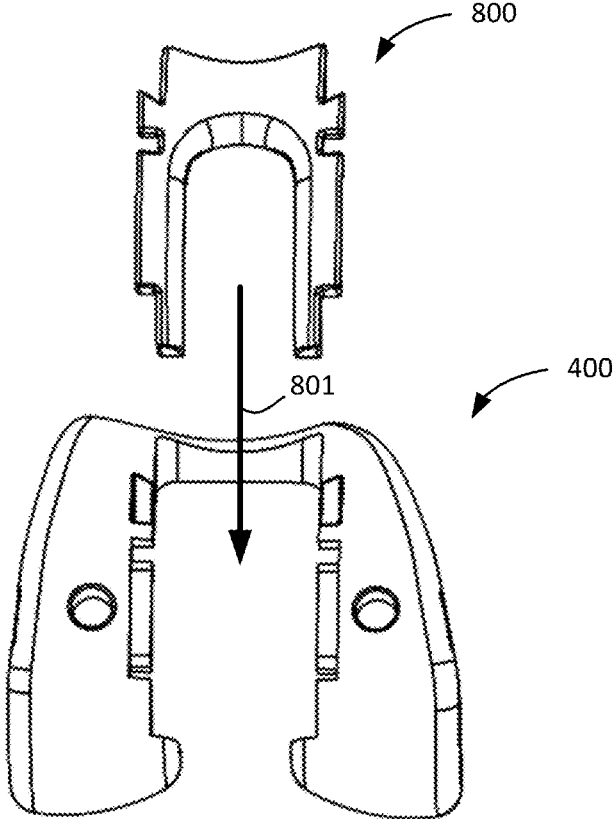

Fig. 34A

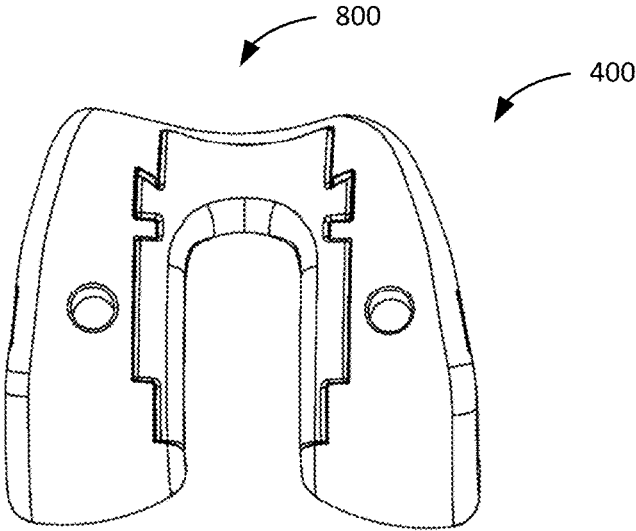

Fig. 34B

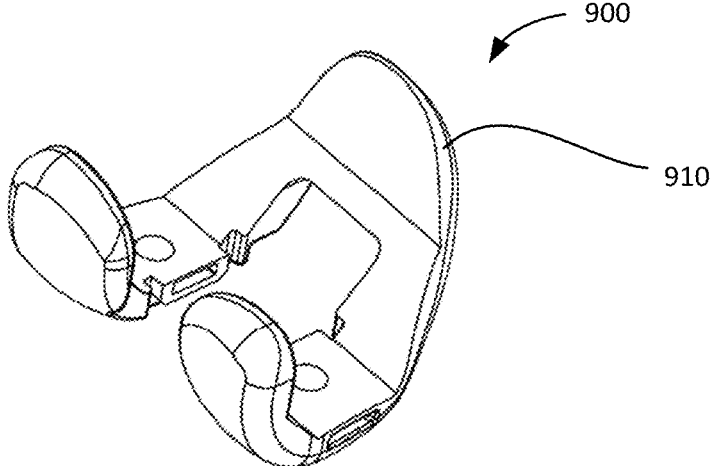

Fig. 35A

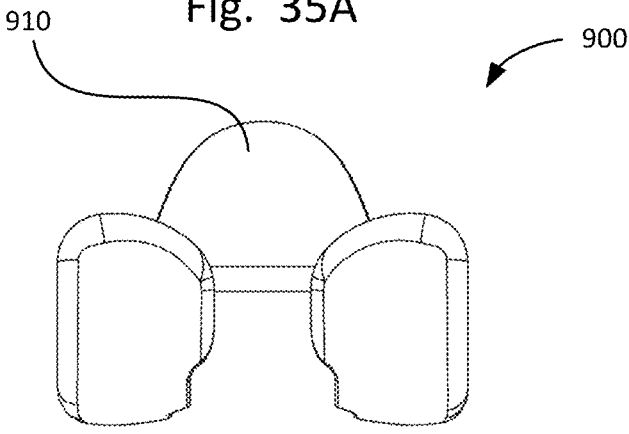

Fig. 35B

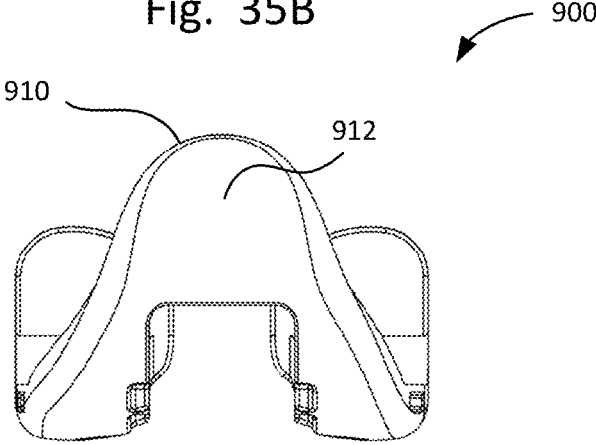

Fig. 35C

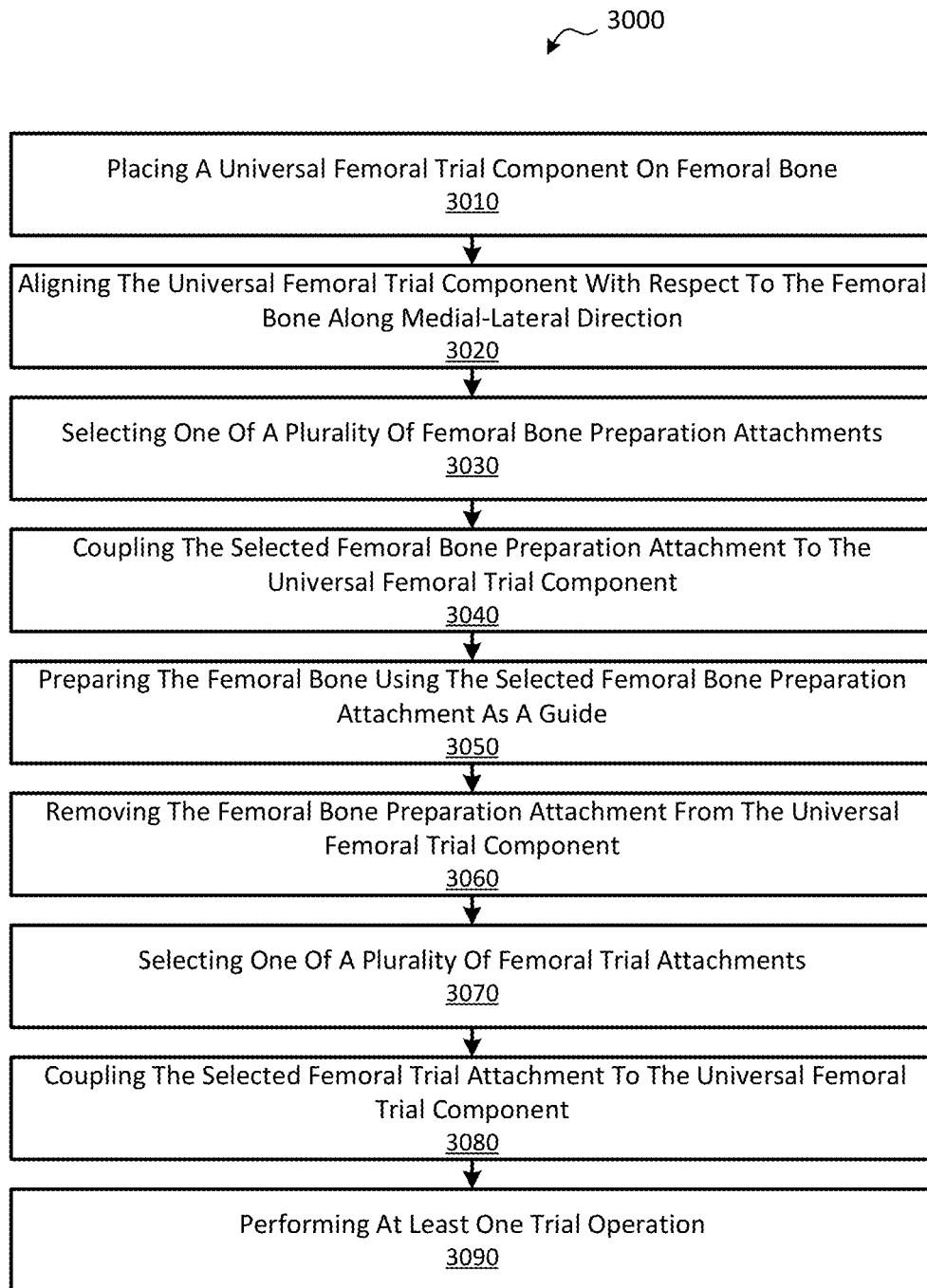

Fig. 36

4000

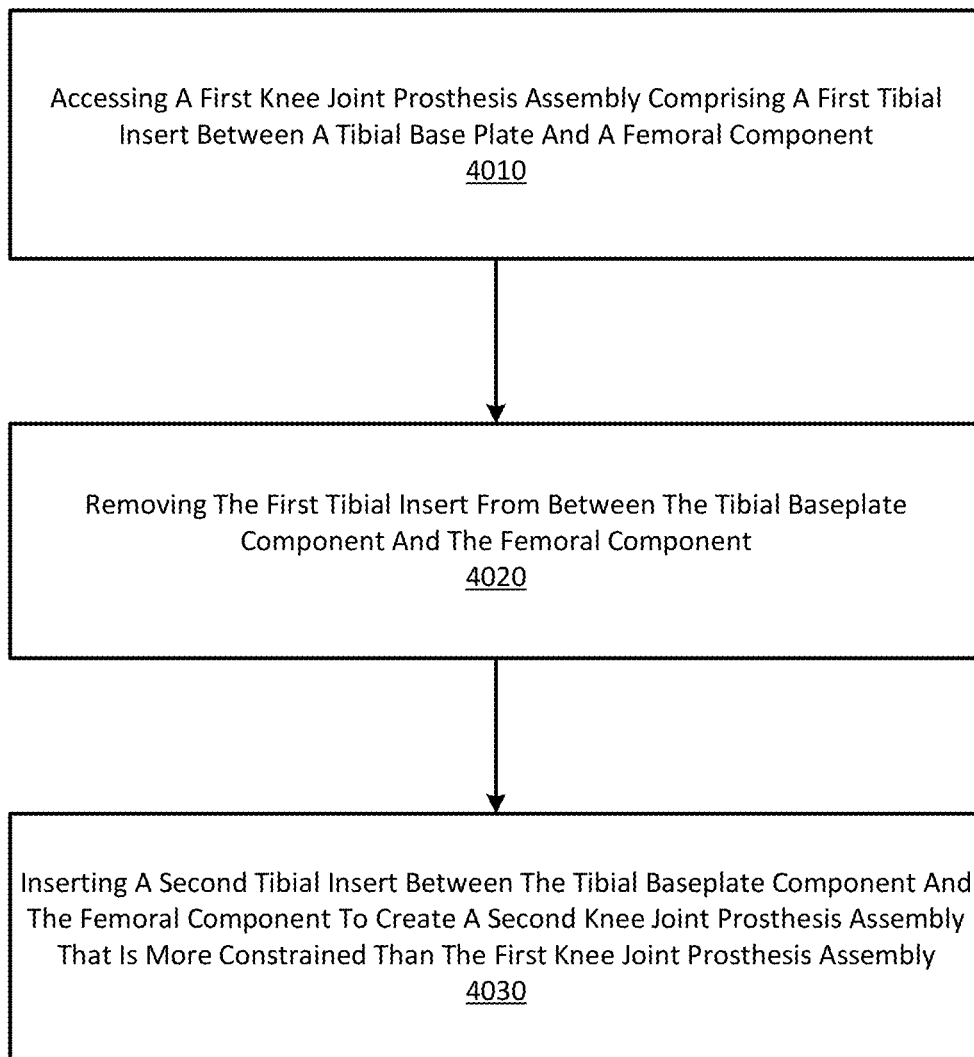

Fig. 37

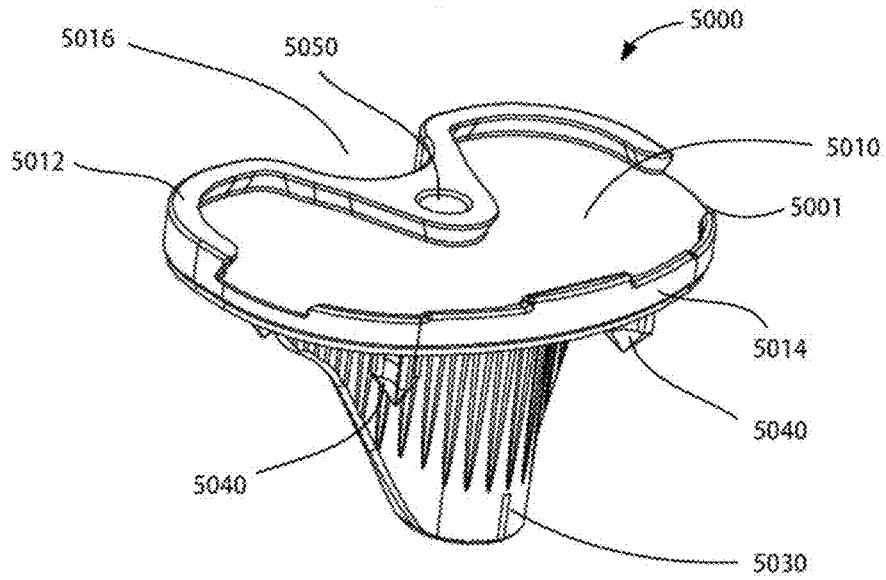

Fig. 38A

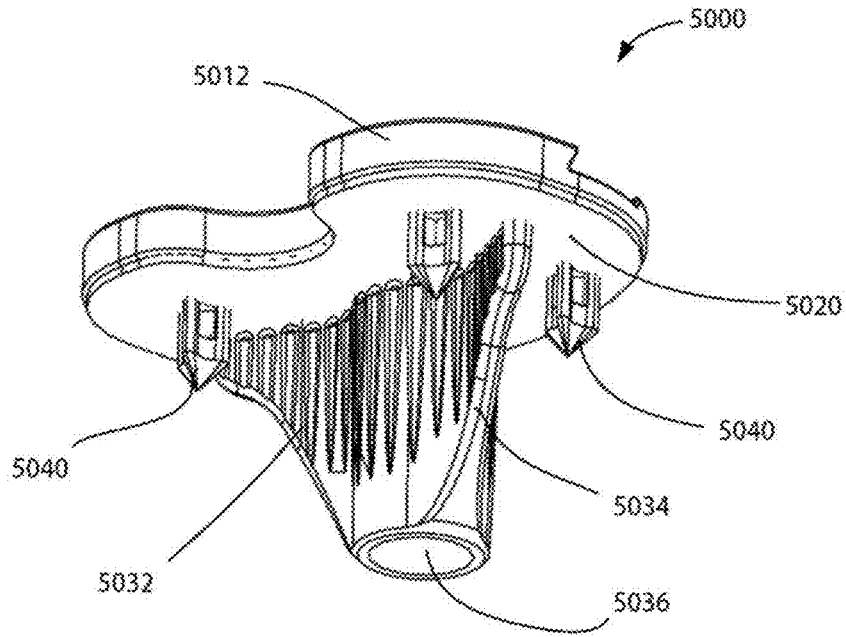

Fig. 38B

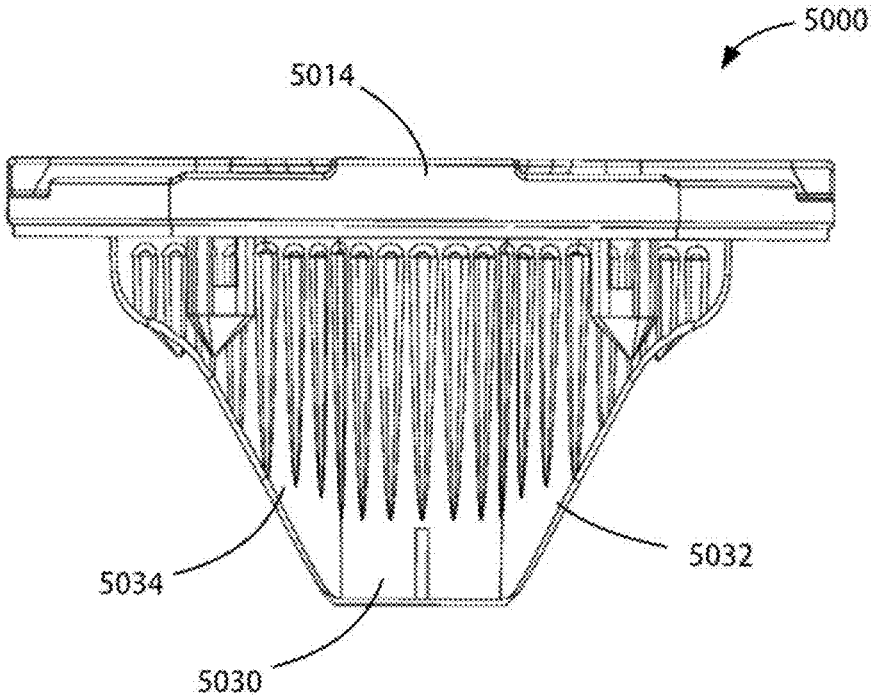

Fig. 38C

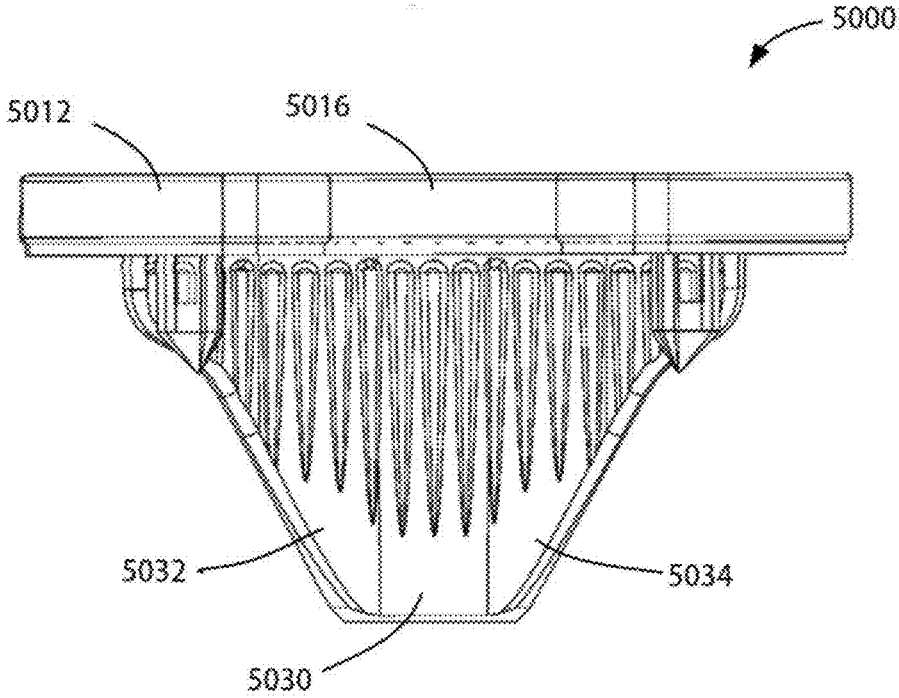

Fig. 38D

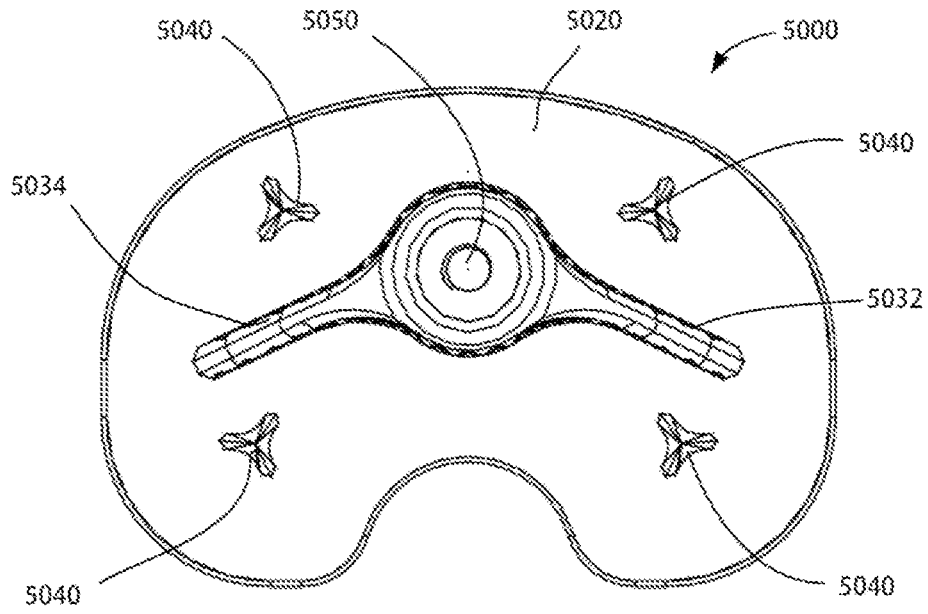

Fig. 38E

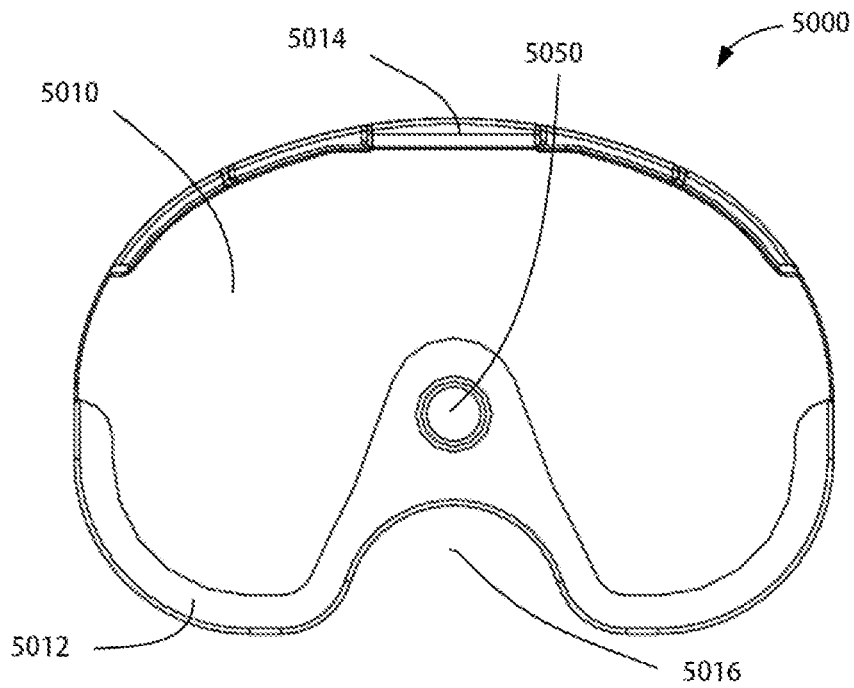

Fig. 38F



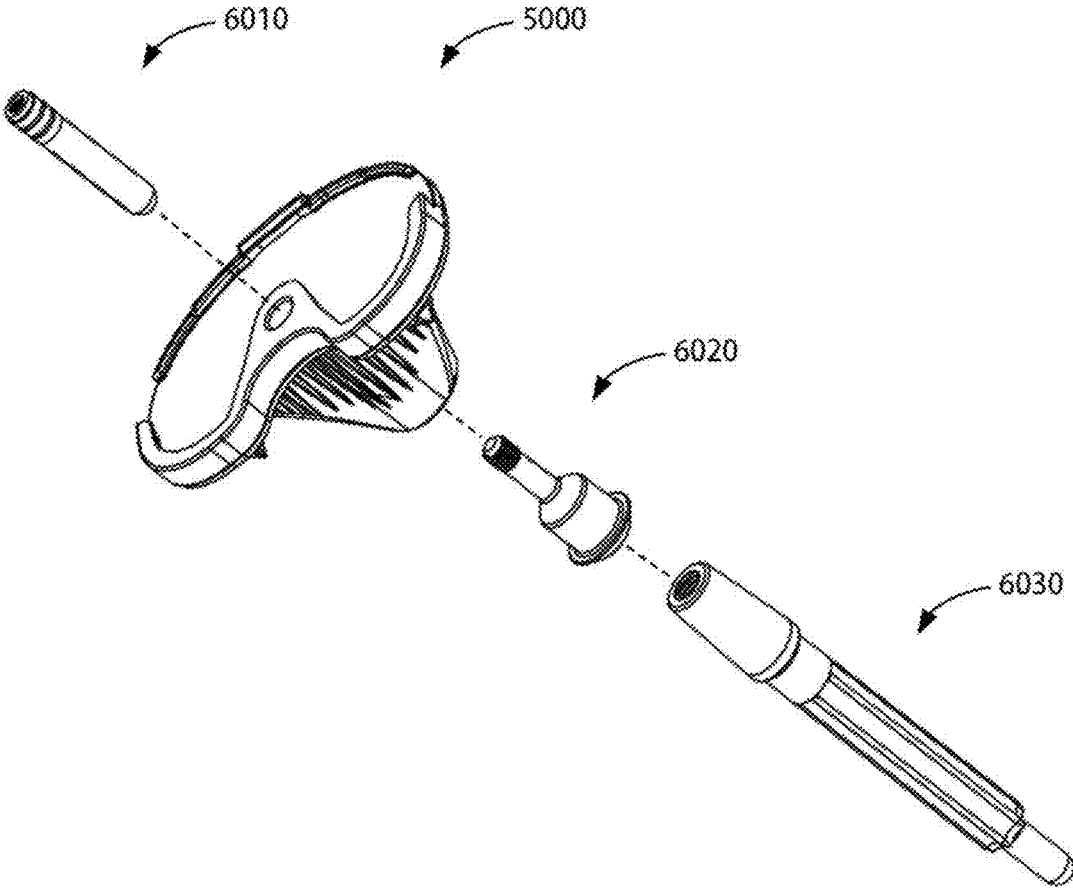
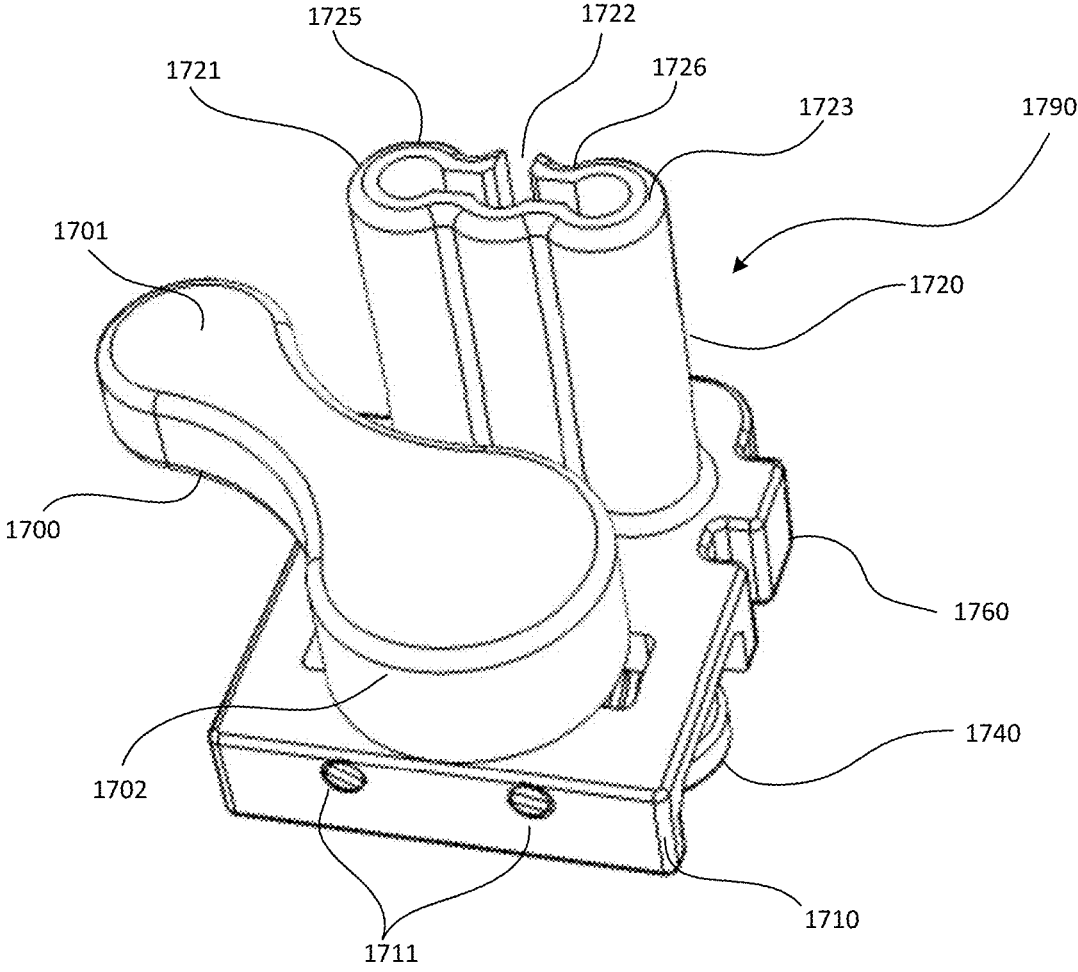
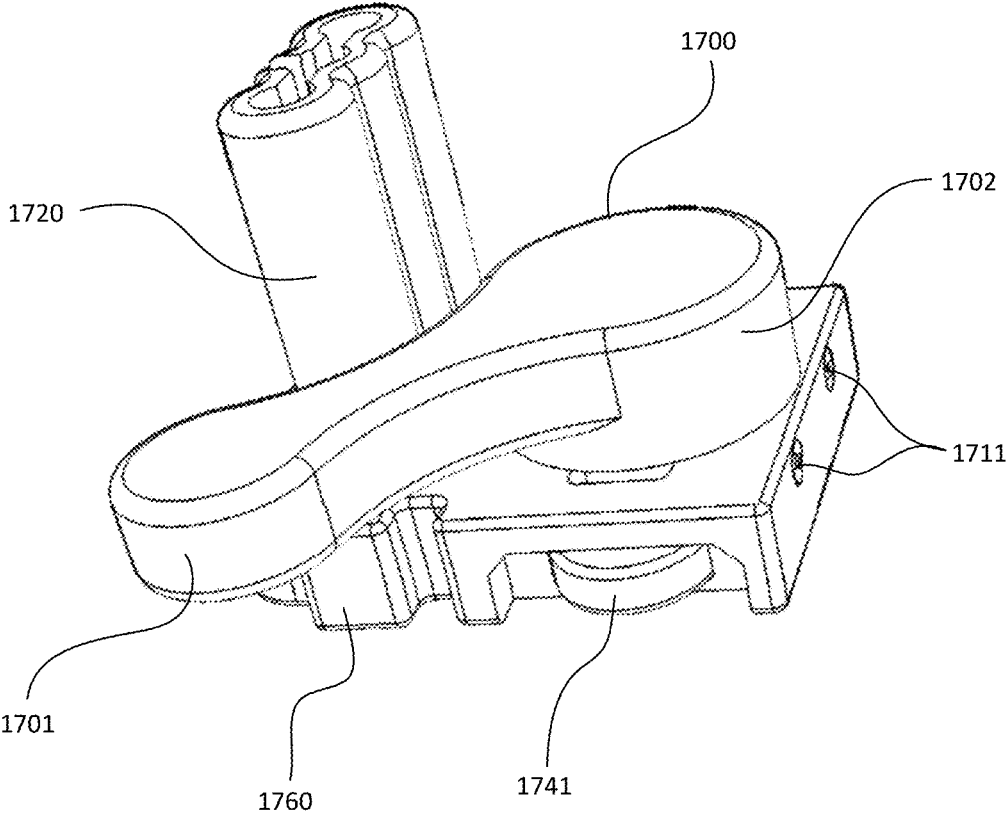

Fig. 39



**Fig. 40**



**Fig. 41**

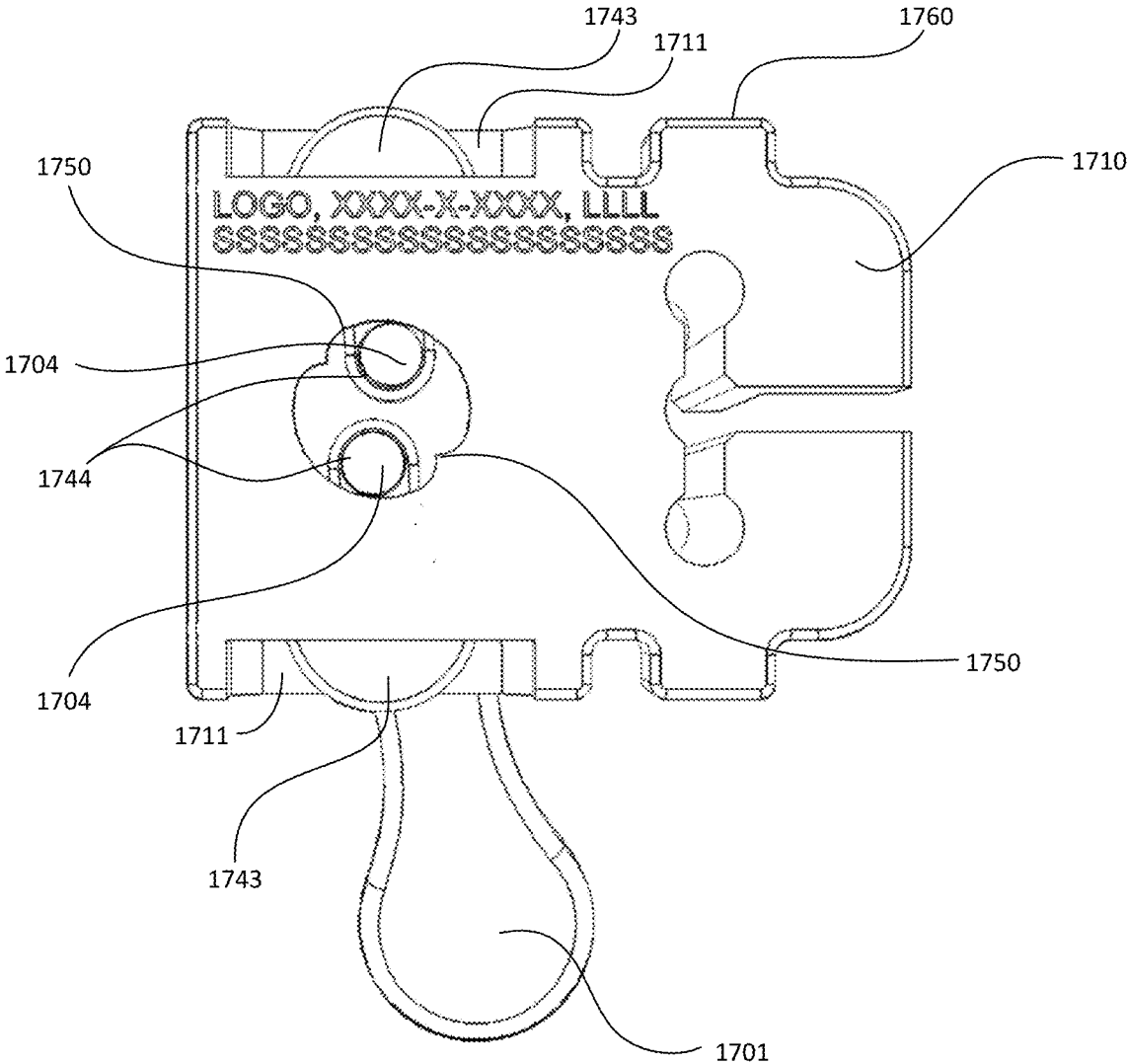
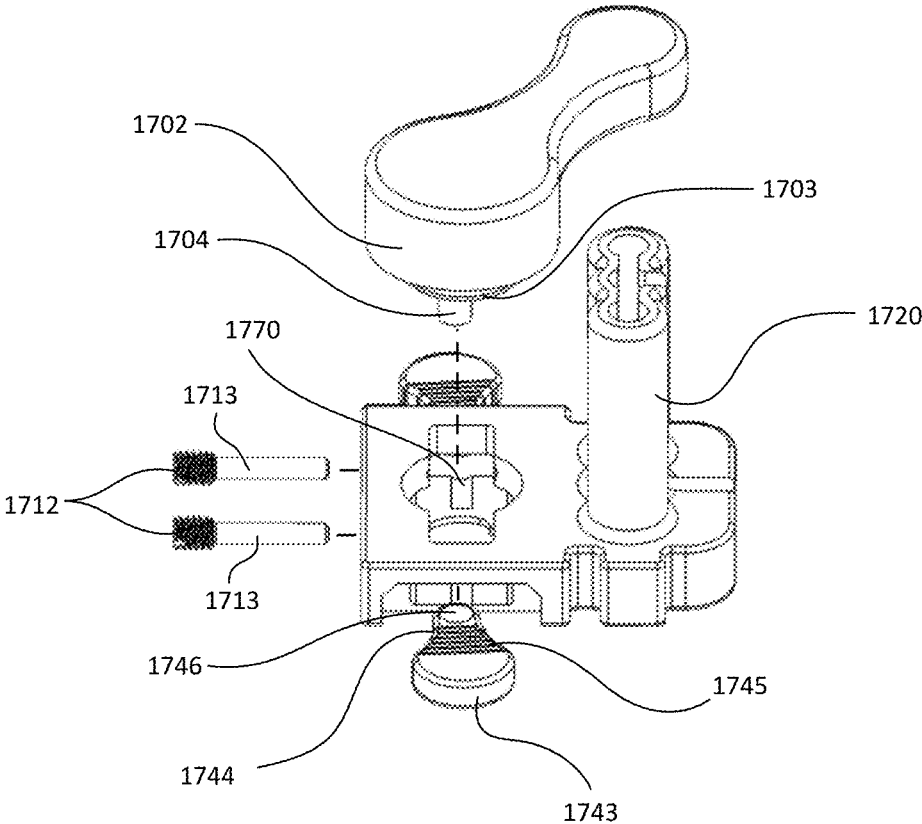
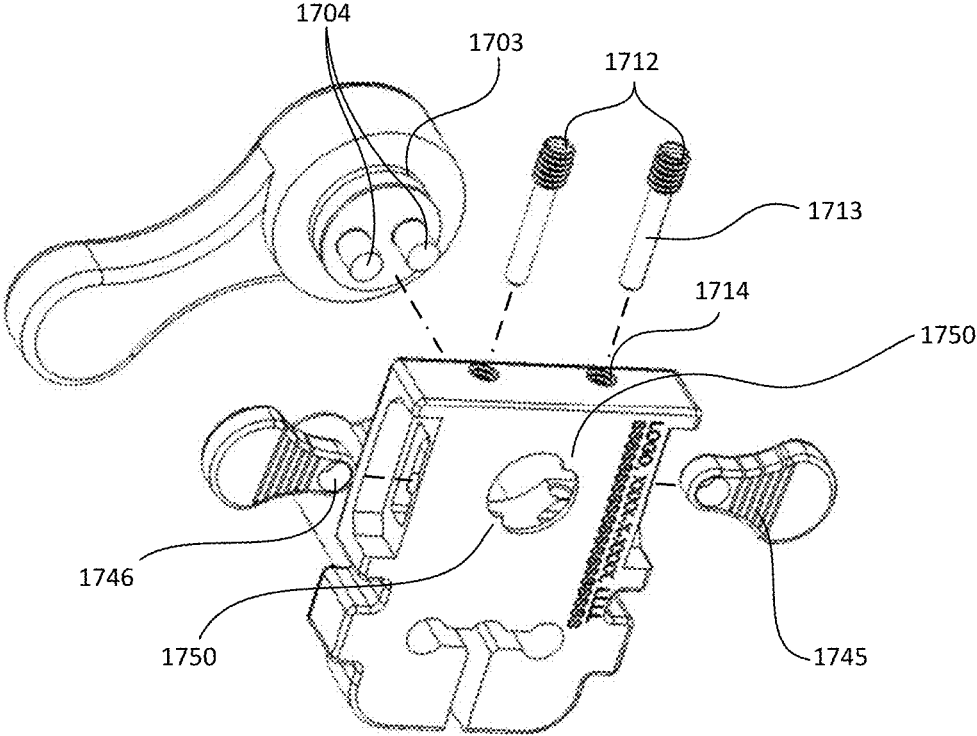

Fig. 42



**Fig. 43**



**Fig. 44**

## UNIVERSAL FEMORAL TRIAL SYSTEM AND METHODS

### CROSS-REFERENCE TO RELATED APPLICATIONS

**[0001]** The present application is a continuation-in-part of U.S. patent application Ser. No. 15/622,688 filed on Jun. 14, 2017, entitled KNEE ARTHROPLASTY SYSTEMS AND METHODS, which claims the benefit of U.S. Provisional Application No. 62/466,249 filed on Mar. 2, 2017, entitled COMPOSITE JOINT ARTHROPLASTY SYSTEMS AND METHODS. The present application is also a continuation-in-part of U.S. patent application Ser. No. 16/046,554 filed on Jul. 26, 2018, entitled MODULAR KNEE PROTHESIS, which claims the benefit of U.S. Provisional Application No. 62/537,106 filed on Jul. 26, 2017, entitled MODULAR KNEE PROTHESIS. The present application is also a continuation-in-part of U.S. patent application Ser. No. 16/505,595 filed on Jul. 8, 2019, entitled ORTHOPEDIC IMPLANTS AND METHODS, which claims the benefit of U.S. Provisional Application No. 62/694,834 filed on Jul. 6, 2018, entitled ORTHOPEDIC IMPLANTS AND METHODS. The present application is also a continuation-in-part of U.S. patent application Ser. No. 16/046,583 filed on Jul. 26, 2018, entitled UNIVERSAL FEMORAL TRIAL SYSTEM AND METHODS, which claims the benefit of U.S. Provisional Application No. 62/537,106 filed on Jul. 26, 2017, entitled MODULAR KNEE PROTHESIS. The above-referenced applications are incorporated by reference as though set forth herein in their entirety.

### TECHNICAL FIELD

**[0002]** The present disclosure relates to surgical devices, systems, instruments, and methods. More specifically, the present disclosure relates to orthopedic knee replacement surgical devices, instruments, systems, and methods.

### BACKGROUND

**[0003]** A number of knee replacement options exist which may be implemented depending upon the level of compromise of the natural knee anatomy. The knee anatomy complex includes the knee joint between the femur distal end and the tibia proximal end, and the surrounding anterior and posterior cruciate ligaments (ACL, PCL), and medial and lateral collateral ligaments (MCL, LCL), which provide support and stabilization to the knee joint. When one or more ligaments are compromised, for example through injury, disease, or aging, a knee prosthesis system may be implanted to replace the knee joint.

**[0004]** In a situation where the anterior cruciate ligament is compromised, it may be removed and a cruciate retaining (CR) knee prosthesis system, which allows retention of the posterior cruciate ligament and the collateral ligaments, may be implanted. Typical CR knee prosthesis femoral components and tibial inserts have large U-shaped openings providing room for the extant PCL, MCL, and LCL ligaments.

**[0005]** In a case where both the anterior and posterior cruciate ligaments are compromised but, yet the collateral ligaments are functional, both the ACL and PCL may be removed, and a posterior stabilizing (PS) knee prosthesis system may be implanted. A typical PS tibial insert includes a central post, and many PS femoral components include a cam element extending between the medial and lateral

condyles. The post and cam interact to provide stability in place of the removed PCL ligament.

**[0006]** In a case where the anterior and posterior cruciate ligaments are compromised, and the collateral ligaments are unstable, both the ACL and PCL may be removed and a constrained condylar knee (CCK) prosthesis system may be implanted. In a case where all four ligaments are compromised, all ligaments may be removed, and a hinge type knee replacement system may be implanted.

**[0007]** A typical knee prosthesis system includes a tibial bone anchoring component, a tibial articulating component, which may be called a tibial insert, and a femoral bone anchoring component. Since the tibial and femoral bone anchoring components are anchored to bone through various fasteners, cement, and/o bone ingrowth, it may be difficult and invasive to remove and replace either of the bone anchoring components, should the need arise. The tibial insert is typically made of polyethylene, and since it is not anchored to bone, is much more easily replaced if necessary. For example, a patient may have a CR knee prosthesis and then experience compromise of the PCL, thus requiring replacement of the CR knee prosthesis with a PS knee prosthesis. Or, a patient may have a PS knee prosthesis and then experience instability of the collateral ligaments, thus requiring replacement of the PS knee prosthesis with a CCK prosthesis.

### SUMMARY

**[0008]** The various systems and methods of the present disclosure have been developed in response to the present state of the art, and in particular, in response to the problems and needs in the art that have not yet been fully solved by currently available technology.

**[0009]** In an embodiment, an assembly for facilitating orthopedic surgery may include a body with a drill guide connected to the body and an attachment mechanism connected to the body. The attachment mechanism may include a first tab, a second tab, and a handle connected to the first and second tabs. The rotation of the handle about an axis may cause the first and second tabs to extend outward from the body to secure the body to an external frame secured to a patient. The drill guide may further include at least one drill guide aperture that extends through the drill guide and through the body. The drill guide may further include at least one broach guide aperture that extends through the drill guide and through the body. The at least one drill guide aperture may be in communication with the at least one broach guide aperture.

**[0010]** The first tab and the second tab each may have a proximal end and a distal end, and the proximal ends of the tabs may be adjacent to one another and the distal ends of the tabs may extend away from each other. The proximal ends of the tabs may each have a handle attachment feature and the handle may further include tab attachment features complementary to the handle attachment features on each of the tabs. The rotation of the handle about the axis may cause each of the first tab and the second tab to transition between a retracted position and an extended position, relative to the body. The proximal ends of the first and second tabs may be located within a cavity in the body so that the handle attachment features and/or the tab attachment features extend into the cavity. At least one of the first tab and the second tab may further include a stop member and the body may further include an abutment member. The rotation of

the handle may cause the stop member to engage the abutment member to retain the at least one of the first tab and the second tab in the extended position.

**[0011]** The first and the second tabs each may have a proximal end, a distal end, and an intermediate section therebetween. The intermediate section may be compressible such that the proximal end and the distal end are configured to be translatable. The assembly may further include the external frame which may be a trial component for joint arthroplasty. The first and second tabs each may have a proximal end, a distal end, and an intermediate section therebetween. The trial component may have a receiving aperture shaped to receive the body and locking apertures, in communication with the receiving aperture, shaped to receive the distal ends of the first tab and the second tab when the handle is rotated with the body positioned in the receiving aperture.

**[0012]** In an embodiment, an assembly may include a body, and a drill and broach guide. The drill and broach guide may include a first drill guide aperture, a second drill guide aperture, a third drill guide aperture, a first broach guide aperture intermediate the first drill guide aperture and the second drill guide aperture, and a second broach guide aperture intermediate the second drill guide aperture and the third drill guide aperture. The second drill guide aperture may be intermediate the first broach guide aperture and the second broach guide aperture. The assembly may have a locking mechanism including a handle connected to the body such that the handle is rotatable about an axis, a first tab having a first proximal end, a first distal end, and a first compressible intermediate section. The first proximal end may have a first handle connection feature, a second tab having a second proximal end, a second distal end, and a second compressible intermediate section. The second proximal end may have a second handle connection feature. The handle may be movably connected to the first handle connection feature and the second handle connection feature such that rotation of the handle about the axis extends the first and second tabs outward from the body.

**[0013]** The first and second tabs may be located within a cavity in the body. At least one of the first tab and the second tab may further have a stop member. The body may further have an abutment member. Rotation of the handle may cause the stop member to engage the abutment member to retain the at least one of the first tab and the second tab in the extended position. The handle may further have a circular base and a grip portion. The circular base may have a concave surface. The body may further have an aperture, surrounding the axis, extending from a first surface of the body to a second surface of the body. The circular base may engage the aperture. The handle may be rotatably secured to the base at the aperture by two pins extending into the base proximate an edge of the aperture, so that the pins securely engage the concave surface, allowing the handle to rotate about the axis.

**[0014]** The assembly may further include an external frame, which may be a trial component for joint arthroplasty. The trial component may further have a receiving aperture shaped to receive the body and locking apertures, in communication with the receiving aperture, shaped to receive the first and second distal ends of the first tab and the second tab when the handle is rotated with the body positioned in the receiving aperture.

**[0015]** In an embodiment, an assembly for preparing and trialing a bone to receive an implant, may include a body, a drill guide connected to the body, and an attachment mechanism connected to the body. The attachment mechanism may further include a first tab, a second tab, and a handle connected to the first and second tabs. The assembly may be configured to be removably coupled to a trial component by rotating the handle such that the first tab and the second tab are first in the retracted position, positioning the assembly adjacent to the trial component, and rotating the handle such that the first tab and the second tab move to the extended position and engage within corresponding attachment apertures in the trial component. At least one of the first tab and the second tab may further include a stop member and the body may further have an abutment member. The rotation of the handle may cause the stop member to engage the abutment member to retain the at least one of the first tab and second tab in in the extended position or a retracted position.

**[0016]** The first and the second tabs each may have a proximal end, a distal end, and an intermediate section therebetween. The handle may engage the first tab and the second tab at the proximal ends. The intermediate section may be compressible, and the handle may be rotatable to transition the first and second tabs to the extended position so that the distal ends of the first and second tabs enter the corresponding attachment apertures in the trial component. The intermediate section may be compressible such that, in response to the distal ends abutting a surface, the intermediate section is compressed to urge the stop member against the abutment member and prevents rotation of the handle. The distal ends may be configured to abut a surface and cause a compression of the intermediate section. The compression may urge the stop member against the abutment member and prevent rotation of the handle. The assembly may further include the external frame. The external frame may be a trial component for joint arthroplasty and may further include a receiving aperture shaped to receive the body. The first and second tabs may each have a proximal end, a distal end, and an intermediate section therebetween. The frame may further have locking apertures, in communication with the receiving aperture, shaped to receive the distal ends of the first tab and the second tab when the handle is rotated with the body positioned in the receiving aperture.

#### BRIEF DESCRIPTION OF THE DRAWINGS

**[0017]** The advantages, nature, and additional features of exemplary embodiments of the disclosure will become more fully apparent from the following description and appended claims, taken in conjunction with the accompanying drawings. Understanding that these drawings depict only exemplary embodiments and are, therefore, not to be considered limiting of the disclosure's scope, the exemplary embodiments of the disclosure will be described with additional specificity and detail through use of the accompanying drawings in which:

**[0018]** FIG. 1A is a perspective rear view of an assembly of the disclosure, including a posterior stabilizing femoral component and a tibial insert coupled in extension; FIG. 1B is a perspective front view of the assembly of FIG. 1A in flexion;

**[0019]** FIG. 2 is an exploded view of the assembly of FIG. 1A;

**[0020]** FIG. 3A is a posterior view of the tibial insert of FIG. 1A; FIG. 3B is an anterior view of the tibial insert of



FIG. 1A; FIG. 3C is a superior view of the tibial insert of FIG. 1A; FIG. 3D is a medial side view of the tibial insert of FIG. 1A;

[0021] FIG. 4 is a top down view of the assembly of FIG. 1A;

[0022] FIG. 5 is a top down cross-sectional view of the assembly of FIG. 1A, taken along line B-B in FIG. 6;

[0023] FIG. 6 is a posterior cross-sectional view of the assembly of FIG. 1A, taken along line A-A in FIG. 5;

[0024] FIG. 7 is a top down cross-sectional view of the assembly of FIG. 1B, taken along line C-C in FIG. 8;

[0025] FIG. 8 is a posterior cross-sectional view of the assembly of FIG. 1B, taken along line D-D in FIG. 7;

[0026] FIG. 9 is a perspective rear view of an assembly of the disclosure, including a cruciate retaining femoral component and the tibial insert of FIG. 1A coupled in extension;

[0027] FIG. 10 is an exploded perspective rear view of the assembly of FIG. 9;

[0028] FIG. 11A is a perspective rear view of another tibial insert of the disclosure; FIG. 11B is a top view of the tibial insert of FIG. 11A; FIG. 11C is a posterior view of the tibial insert of FIG. 11A; FIG. 11D is an anterior view of the tibial insert of FIG. 11A; FIG. 11E is a bottom view of the tibial insert of FIG. 11A;

[0029] FIG. 12A is a perspective rear view of another tibial insert of the disclosure; FIG. 12B is a top view of the tibial insert of FIG. 12A; FIG. 12C is a bottom view of the tibial insert of FIG. 12A; FIG. 12D is a posterior view of the tibial insert of FIG. 12A; FIG. 12E is an anterior view of the tibial insert of FIG. 12A; FIG. 12F is a medial side view of the tibial insert of FIG. 12A;

[0030] FIG. 13 is a chart demonstrating the interchangeability of the tibial inserts disclosed herein with various femoral components;

[0031] FIG. 14 is an exploded rear view of another assembly of the disclosure, including a posterior stabilizing femoral component and a posterior stabilizing tibial insert;

[0032] FIG. 15 is another exploded rear view of the assembly of FIG. 14;

[0033] FIG. 16A is a posterior view of the tibial insert of FIG. 14; FIG. 16B is an anterior view of the tibial insert of FIG. 14; FIG. 16C is a superior view of the tibial insert of FIG. 14; FIG. 16D is a medial side view of the tibial insert of FIG. 14;

[0034] FIG. 17 is an exploded rear view of another assembly of the disclosure, including a cruciate retaining femoral component with a keel and the posterior stabilizing tibial insert of FIG. 14;

[0035] FIG. 18 is another exploded rear view of the assembly of FIG. 17;

[0036] FIG. 19 is an exploded rear view of another assembly of the disclosure, including a cruciate retaining femoral component without a keel and the posterior stabilizing tibial insert of FIG. 14;

[0037] FIG. 20 is another exploded rear view of the assembly of FIG. 19;

[0038] FIG. 21A is a perspective rear view of another tibial insert of the disclosure; FIG. 21B is a top view of the tibial insert of FIG. 21A; FIG. 21C is a posterior view of the tibial insert of FIG. 21A; FIG. 21D is an anterior view of the tibial insert of FIG. 21A; FIG. 21E is a bottom view of the tibial insert of FIG. 21A;

[0039] FIG. 22A is a perspective rear view of another tibial insert of the disclosure; FIG. 22B is a top view of the

tibial insert of FIG. 22A; FIG. 22C is a bottom view of the tibial insert of FIG. 22A; FIG. 22D is a posterior view of the tibial insert of FIG. 22A; FIG. 22E is an anterior view of the tibial insert of FIG. 22A; FIG. 22F is a medial side view of the tibial insert of FIG. 22A;

[0040] FIG. 23A is a perspective front view of the femoral component of FIG. 14 coupled to one or more augments of the present disclosure; FIG. 23B is a medial side view of the femoral component of FIG. 23A;

[0041] FIG. 24A is a perspective top view of a femoral trial component of the disclosure; FIG. 24B is a perspective rear view of the femoral trial component of FIG. 24A; FIG. 24C is a lateral side view of the femoral trial component of FIG. 24A; FIG. 24D is a medial side view of the femoral trial component of FIG. 24A; FIG. 24E is an anterior view of the femoral trial component of FIG. 24A; FIG. 24F is a posterior view of the femoral trial component of FIG. 24A; FIG. 24G is a superior view of the femoral trial component of FIG. 24A; FIG. 24H is an inferior view of the femoral trial component of FIG. 24A;

[0042] FIG. 25A is a perspective rear view of a posterior stabilizing notch cutting guide assembly of the disclosure; FIG. 25B is another perspective rear view of the posterior stabilizing notch cutting guide assembly of FIG. 25A; FIG. 25C is a medial side view of the posterior stabilizing notch cutting guide assembly of FIG. 25A; FIG. 25D is a top view of the posterior stabilizing notch cutting guide assembly of FIG. 25A;

[0043] FIG. 26 is a partial exploded view of the posterior stabilizing notch cutting guide assembly of FIG. 25A;

[0044] FIG. 27A is a posterior view of the posterior stabilizing notch cutting guide assembly of FIG. 25A above the femoral trial component of FIG. 24A; FIG. 27B is posterior view of the posterior stabilizing notch cutting guide assembly of FIG. 27A coupled to the femoral trial component of FIG. 27A;

[0045] FIG. 28A is a perspective rear view of a posterior stabilizing trial attachment of the disclosure; FIG. 28B is another perspective rear view of the posterior stabilizing trial attachment of FIG. 28A; FIG. 28C is a perspective front view of the posterior stabilizing trial attachment of FIG. 28A; FIG. 28D is a perspective side view of the posterior stabilizing trial attachment of FIG. 28A;

[0046] FIG. 29A is a posterior view of the posterior stabilizing trial attachment of FIG. 28A above the femoral trial component of FIG. 24A; FIG. 29B is a posterior view of the posterior stabilizing trial attachment of FIG. 29A coupled to the femoral trial component of FIG. 29A;

[0047] FIG. 30A is a perspective rear view of a drill and broach guide assembly of the disclosure; FIG. 30B is a perspective bottom view of the drill and broach guide assembly of FIG. 30A; FIG. 30C is a top view of the drill and broach guide assembly of FIG. 30A; FIG. 30D is a bottom view of the drill and broach guide assembly of FIG. 30A;

[0048] FIG. 31 is a partial exploded view of the drill and broach guide assembly of FIG. 30A;

[0049] FIG. 32A is a posterior view of the drill and broach guide assembly of FIG. 30A above the femoral trial component of FIG. 24A; FIG. 32B is a posterior view of the drill and broach guide assembly of FIG. 32A coupled to the femoral trial component of FIG. 32A;

[0050] FIG. 33A is a perspective front view of a cruciate retaining trial attachment of the disclosure; FIG. 33B is a

perspective rear view of the cruciate retaining trial attachment of FIG. 33A; FIG. 33C is a perspective bottom view of the cruciate retaining trial attachment of FIG. 33A; FIG. 33D is a top view of the cruciate retaining trial attachment of FIG. 33A;

[0051] FIG. 34A is a posterior view of the cruciate retaining trial attachment of FIG. 33A above the femoral trial component of FIG. 24A; FIG. 34B is a posterior view of the cruciate retaining trial attachment of FIG. 34A coupled to the femoral trial component of FIG. 34A;

[0052] FIG. 35A is a perspective rear view of another femoral trial component of the disclosure; FIG. 35B is a posterior view of the femoral trial component of FIG. 35A; FIG. 35C is an anterior view of the femoral trial component of FIG. 35A;

[0053] FIG. 36 is a flow chart diagram of a method for preparing and trialing a femoral bone with a femoral trial component;

[0054] FIG. 37 is a flow chart diagram of a method for revising a knee joint prosthesis to provide increased stability;

[0055] FIG. 38A is a perspective front view of a tibial tray of the disclosure; FIG. 38B is a perspective rear view of the tibial tray of FIG. 38A; FIG. 38C is an anterior view of the tibial tray of FIG. 38A; FIG. 38D is a posterior view of the tibial tray of FIG. 38A; FIG. 38E is a bottom view of the tibial tray of FIG. 38A; FIG. 38F is a top view of the tibial tray of FIG. 38A; and

[0056] FIG. 39 is an exploded view of a tibial tray mounting system of the disclosure that utilizes the tibial tray of FIG. 38A.

[0057] FIG. 40 is a perspective rear view of an embodiment of a drill and broach guide assembly of the disclosure.

[0058] FIG. 41 is a side perspective view of the drill and broach guide assembly of FIG. 40.

[0059] FIG. 42 is a bottom view of the drill and broach guide assembly of FIG. 40.

[0060] FIG. 43 is a partial exploded view of the drill and broach guide assembly of FIG. 40.

[0061] FIG. 44 is a partial exploded bottom perspective view of the drill and broach guide assembly of FIG. 40.

[0062] It is to be understood that the drawings are for purposes of illustrating the concepts of the disclosure and may not be to scale. Furthermore, the drawings illustrate exemplary embodiments and do not represent limitations to the scope of the disclosure.

#### DETAILED DESCRIPTION

[0063] Exemplary embodiments of the disclosure will be best understood by reference to the drawings, wherein like parts are designated by like numerals throughout. It will be readily understood that the components of the disclosure, as generally described and illustrated in the Figures herein, could be arranged and designed in a wide variety of different configurations. Thus, the following more detailed description of the embodiments of the apparatus, instruments, systems, and methods, as represented in the Figures, is not intended to limit the scope of the disclosure, as claimed, but is merely representative of exemplary embodiments of the disclosure.

[0064] Disclosed herein are components for a modular knee prosthesis system. This system may allow for revision procedures by replacement of only the tibial insert, allowing the originally implanted femoral and tibial anchoring com-

ponents to remain implanted. The system may include CR tibial inserts, PS tibial inserts, and/or CCK tibial inserts. Any one of these tibial inserts may be interchangeably used with CR and/or PS femoral components disclosed herein to provide the stabilization needed to substitute for compromised or removed ligaments. The system may be used with any suitable tibial baseplate component, or tibial tray, to support the tibial insert. The PS tibial inserts disclosed herein may include tapered posts that permit the inserts to be used with cruciate retaining (CR) femoral components and/or posterior stabilizing (PS) femoral components.

[0065] Referring to FIGS. 1A-2, an assembly 10 for an implantable knee prosthesis is shown including a femoral component 14 and a tibial insert 12. The femoral component 14 and tibial insert 12 are shown coupled in extension in FIG. 1A, coupled in flexion in FIG. 1B, and shown in an exploded view in FIG. 2. The tibial insert 12 may be further coupled to a tibial baseplate component (not shown) which may be implanted in a prepared tibia of a patient (also not shown). The femoral component 14 and tibial insert 12 illustrated in FIGS. 1A-2 are right femoral and tibial insert components. Left femoral and tibial insert components (not shown) would be mirror images of the right femoral and tibial insert components shown in FIGS. 1A-2. The femoral component 14 may also be referred to as a posterior stabilizing femoral component 14 (or "PS femoral component") and the tibial insert 12 may also be referred to as a posterior stabilizing tibial insert (or "PS insert").

[0066] FIGS. 3A-3D show the PS insert 12 of FIGS. 1A-2 in isolation. The PS insert 12 may include a fixation side 20, which may be an inferior side, opposite an articulation side 22, which may be a superior side. The articulation side 22 may include a medial articulation portion 24 having a medial condylar articulation surface 25 and a lateral articulation portion 26 having a lateral condylar articulation surface 27. A central portion 28 may separate the medial articulation portion 24 from the lateral articulation portion 26. A post 30 may protrude superiorly from the central portion 28 and extend from a post base 38 to a post top or post superior end 40. From the anterior perspective (shown in FIG. 3B) and/or the posterior perspective (shown in FIG. 3A), the post 30 may have its maximum medial-lateral or horizontal width toward the post superior end 40 of the post 30, and its minimum medial-lateral or horizontal width toward the post base 38 of the post 30. The post 30 may also be bilaterally symmetrical from the anterior and/or posterior perspectives. A recess 45 may be formed posterior to the central portion 28, between the medial and lateral articulation portions 24, 26, and may provide room for a posterior cruciate ligament (not shown). The PS insert 12 may further include an insert base 46, which may further include an engagement feature 48 for engagement with a tibial baseplate component.

[0067] Continuing with FIGS. 1A-3D, the post 30 may have an articulation surface 31 extending around the post 30 on the medial, posterior, lateral, and anterior aspects of the post 30. The articulation surface 31 may include a medial articulation surface 32, a lateral articulation surface 34, an anterior post surface 36, and a posterior articulation surface 42. The medial and lateral articulation surfaces 32, 34 may be non-parallel to one another and taper inward from the post superior end 40 to the post base 38 relative to an insert midline vertical axis 2, as shown in FIGS. 3A and 3B. As shown in FIG. 3A, an angle  $\theta$  between the vertical axis 2 and each tapered surface 32, 34 may be about 6.5°, in at least one

embodiment. Since the post 30 may be bilaterally symmetrical, the angle  $\theta$  may be the same on both the medial and lateral articulation surfaces 32, 34 of the post 30. In other embodiments of the disclosure, angle  $\theta$  may range from about 6° to 11° degrees. The medial articulation surface 32 may be continuous with the medial condylar articulation surface 25, and the lateral articulation surface 34 may be continuous with the lateral condylar articulation surface 27, as can be further seen in cross-section in FIGS. 6 and 8. The anterior post surface 36 may extend between the medial and lateral articulation surfaces 32, 34 and may be convexly rounded. The anterior post surface 36 may also taper outward from the post superior end 40 to the post base 38 relative to the midline vertical axis 2, as best seen in FIG. 3D. In other embodiments of the PS insert 12, the anterior post surface 36 may include less or no taper.

[0068] Referring to FIG. 3C, the boundary of the post superior end 40 defines a rounded rim 44 shaped as a portion of a circle defined by a circular envelope 47, as seen from a superior perspective. The post superior end 40 and rim 44 may be crescent-shaped with a concave recess toward a posterior end of the post 30 as shown, and may permit passage of the posterior cruciate ligament. The post superior end 40 may be circular; the rim 44 may provide increased rotational range of motion and surface contact against the femoral component 14 in comparison to traditional posts with a more square or rectangular shape and no rim. Thus, the rounded post superior end 40 and rim 44 may allow for surface contact with the femoral component 14 in contrast to the mere point or edge contact that is achieved by traditional posts that do not have these features.

[0069] The PS femoral component 14 depicted in FIGS. 1-8 may include a cam element or cam bar 50 and a box structure 52 for providing posterior stabilization in place of absent ligaments. The cam bar 50 may include a cam articulating surface 51 which may contact the posterior articulation surface 42 of the post 30 during flexion, as in FIGS. 1B and 7. An internal articulation surface 54 may reside on the inside of the box structure 52 and may contact the post 30 during articulation and rotation of the knee joint. The internal articulating surface 54 may be concavely curved, and may contact the rim 44 of the post 30 during axial rotation of the knee joint about the post. The PS femoral component 14 may further include a medial condyle 60 having a medial condylar articulation surface 62, and a lateral condyle 64 having a lateral condylar articulation surface 66. The medial and lateral condylar articulation surfaces 62, 66 may articulate against the PS insert 12 medial and lateral condylar articulation surfaces 25, 27 respectively. A gap 68 may be formed between the medial and lateral condyles 60, 64, with the cam bar 50 extending medial-laterally across the gap 68. The internal articulation surface 54 may include a medial portion 70 continuous with a lateral portion 72. In the embodiment depicted, a fixation post 74 may protrude superiorly from the PS femoral component 14. However, in other embodiments of the PS femoral component 14, the fixation post 74 may be absent and/or other fixation features such as posts, spikes, pegs, webs, keels or teeth may be present to affix the PS femoral component 14 to a prepared femur (not shown).

[0070] Referring to FIGS. 9 and 10, another assembly 110 embodiment of the disclosure may include the PS insert 12 of FIGS. 1-8 coupled with a cruciate retaining femoral component 114 (or "CR femoral component"). The CR

femoral component 114 may include medial and lateral condyles 160, 164, with a gap 168 formed between the medial and lateral condyles 160, 164. As a CR femoral component 114, no cam bar or box may be present. The medial and lateral condyles 160, 164 may include medial and lateral condylar articulation surfaces 162, 166, and an internal articulation surface 154 with medial and lateral articulating surfaces 170, 172.

[0071] The medial and lateral articulation surfaces 32, 34 of the post 30 may be tapered and may permit natural articulation of the CR femoral component 114 with the PS insert 12, which may not be achievable if the post 30 were not tapered. For example, if the post 30 had straight sides instead of tapered sides, the wider width of the post 30 at the base of the post 30 would interfere with the internal articulating surfaces 170, 172 of the medial and lateral condyles 160, 164. When the PS femoral component 14 is coupled with the PS insert 12 to form assembly 10, as in FIG. 1A and FIG. 4, the circular shape of the post superior end 40 in combination with the tapered medial and lateral articulation surfaces 32, 34 of the post 30, may permit the PS femoral component 14 to articulate relative to the PS insert 12 in the manner of a posterior stabilized femoral component. However, when the PS insert 12 is paired and implanted with the CR femoral component 114, the resultant assembly 110 may provide the native articulation and rotation of a cruciate retaining implant.

[0072] Referring to FIGS. 11A-11E, an alternative embodiment of a tibial insert 212 is shown. Tibial insert 212 may be referred to as a cruciate retaining tibial insert 212 (or "CR insert"). In a system of the disclosure, CR insert 212 may be implanted with the CR femoral component 114 and a tibial baseplate component (not shown) to form a cruciate retaining knee prosthesis system. The CR insert 212 may include a fixation side 220, which may be an inferior side, opposite an articulation side 222, which may be a superior side. The articulation side 222 may include a medial articulation portion 224 having a medial condylar articulation surface 225 and a lateral articulation portion 226 having a lateral condylar articulation surface 227. A central portion 228 may separate the medial articulation portion 224 from the lateral articulation portion 226. A recess 245 may be formed posterior to the central portion 228, between the medial and lateral articulation portions 224, 226, and may provide room for a posterior cruciate ligament. The CR insert 212 may further include an insert base 246 and an engagement feature 248 for engagement with a tibial baseplate component. The CR insert 212 may be coupled with the CR femoral component 114 to form a cruciate retaining assembly. This assembly may be implanted with a suitable tibial baseplate as a cruciate retaining knee prosthesis. The CR insert 212 may also be coupled with the PS femoral component 14 and implanted with a suitable tibial baseplate.

[0073] Referring to FIGS. 12A-12F, another alternative embodiment of a tibial insert 312 is shown. The tibial insert 312 may be referred to as a constrained condylar knee (CCK) tibial insert 312 (or "CCK insert"). The CCK insert 312 may include a fixation side 320, which may be an inferior side, opposite an articulation side 322, which may be a superior side. The articulation side 322 may include a medial articulation portion 324 having a medial condylar articulation surface 325 and a lateral articulation portion 326 having a lateral condylar articulation surface 327. A central portion 328 may separate the medial articulation portion 324

from the lateral articulation portion 326. A post 330 may protrude superiorly from the central portion 328, and extend from a post base 338 to a top, or post superior end 340. From the anterior perspective, as shown in FIG. 12E, and the posterior perspective, as shown in FIG. 12D, the post 330 may have its maximum medial-lateral or horizontal width at the superior end 340 of the post 330, and its minimum medial-lateral or horizontal width at the post base 338 of the post 330. The post 330 may be bilaterally symmetrical from the anterior and posterior perspectives. The CCK insert 312 may further include an insert base 346 and an engagement feature 348 for engagement with a tibial tray (not shown).

[0074] The post 330 may have an articulation surface 331 extending around the post 330 on the medial, posterior, lateral, and anterior aspects of the post 330. The articulation surface 331 may include a medial articulation surface 332, a lateral articulation surface 334, an anterior post surface 336, and a posterior articulation surface 342. The medial and lateral articulation surfaces 332, 334 may taper slightly inward from the post superior end 340 to the post base 338 of the post 330 relative to an insert midline vertical axis 2. However, some embodiments of CCK insert 312 may include no taper of the medial and lateral articulation surfaces 332, 334. The medial articulation surface 332 may be continuous with the medial condylar articulation surface 325, and the lateral articulation surface 334 may be continuous with the lateral condylar articulation surface 327. The anterior post surface 336 may extend between the medial and lateral surfaces 332, 334 and may be convexly rounded. The anterior post surface 336 may taper outward from the post superior end 340 to the post base 338 relative to the midline axis 2, as best seen in FIG. 12F. In other embodiments of the CCK insert 312, the anterior post surface 336 may include less taper, more taper, and/or no taper. The post 330 of the CCK insert 312 may be wider and bigger in diameter than the post 30 of PS insert 12, for example to provide increased stability in the case of removal of the collateral ligaments.

[0075] Referring to FIG. 12B, the boundary of the post superior end 340 may define a rounded rim 344 shaped as a portion of a circle, from a superior perspective. The post superior end 340 and rim 344 may be semi-circular as shown, however the rim 344 may define a circular envelope 347. The post superior end 340 may be circular and rim 344 may provide increased surface contact and rotational range of motion when coupled and implanted with the PS femoral component 14 in comparison to traditionally shaped posts with a more square or rectangular shaped post. Thus, the rounded post superior end 340 and rim 344 may allow for surface contact with the femoral component 14 in contrast to the mere point or edge contact that is achieved by traditional posts that do not have these features. The CCK insert 312 may be coupled with the PS femoral component 14 to form a constrained condylar knee assembly, and this assembly may be implanted with a suitable tibial baseplate as a constrained condylar knee prosthesis. The CCK insert 312 may also be coupled with the CR femoral component 114 and implanted with a suitable tibial baseplate. Thus, all of the tibial inserts 12, 212, and 312 disclosed herein are interchangeable with both the CR femoral component 114 and the PS femoral component 14. FIG. 13 is a chart showing the potential combinations of components.

[0076] The tibial inserts 12, 212, 312, PS femoral component 14 and CR femoral component 114 may be grouped

together as a modular knee replacement system and provided as a kit in one or more packages, in one non-limiting example. Another kit may include a CR femoral component 114, a PS insert 12 and a CR insert 212, in one or more packages in another non-limiting example. Yet another kit may include a PS femoral component 14, a PS insert 12, a CR insert 212, and a CCK insert 312, in one or more packages in yet another non-limiting example. However, it will also be understood that other kit embodiments may utilize any of the tibial inserts and/or femoral components described herein in any number or combination, in one or more packages. Furthermore, other components may also be including in any kit described herein, such as suitable tibial baseplate components, patellar components, etc., in one or more packages. It will also be understood that any of the tibial inserts disclosed herein may be formed of vitamin E polyethylene, highly cross linked polyethylene, ultra-high molecular weight polyethylene (UHMWPE), or any other suitable material.

[0077] In a method of the disclosure, a patient may initially experience compromise of the anterior cruciate ligament. The ACL may be removed, and a CR type prosthesis may be implanted, including a CR femoral component 114, a CR insert 212, and a tibial baseplate component. Later, the same patient may experience compromise of the PCL and may need additional stabilization of the knee joint. The PCL may be removed, the CR tibial insert 212 may be removed, and a PS tibial insert 12 of the disclosure may be inserted between the originally implanted CR femoral component 114 and the tibial baseplate component, thus providing additional stability for the missing PCL. Even later, the same patient may experience instability of the collateral ligaments. The PS tibial insert 12 may be removed, and the CCK tibial insert 312 of the disclosure may be inserted between the originally implanted CR femoral component 114 and the tibial baseplate component. Thus, the patient may progress from a CR knee prosthesis, to a PS knee prosthesis, and finally to a CCK knee prosthesis without requiring replacement of the originally implanted femoral and/or tibial baseplate components. The interchangeability of the inserts 12, 212, 312 permit replacement of only the tibial insert component in order to provide increasing levels of support and stability to the knee joint.

[0078] In another method of the disclosure, a patient may initially experience compromise of both the ACL and the PCL. These ligaments may be removed, and a PS type prosthesis may be implanted, including a PS femoral component 14, a PS insert 12, and a tibial baseplate component. Later, the same patient may experience instability of the collateral ligaments. The PS insert 12 may be removed, and a CCK insert 312 may be inserted between the originally implanted PS femoral component 14 and the tibial baseplate component. Thus, the patient may progress from a PS knee prosthesis to a CCK knee prosthesis without requiring replacement of the originally implanted PS femoral component 14 and tibial baseplate component.

[0079] Referring to FIGS. 14 and 15, another assembly 1010 of the disclosure for an implantable knee prosthesis is shown in various exploded rear views. The assembly 1010 may include a femoral component 1014 and a tibial insert 1012. The tibial insert 1012 may be further coupled to a tibial baseplate component (not shown) which may also be implanted in a prepared tibia of a patient (not shown). The femoral component 1014 and tibial insert 1012 illustrated in

FIGS. 14 and 15 are right side femoral and tibial insert components. Left side femoral and tibial insert components (not shown) would be mirror images of the right side femoral and tibial insert components that are shown in FIGS. 14 and 15. The femoral component 1014 may also be referred to as a posterior stabilizing femoral component 1014 (or “PS femoral component”) and the tibial insert 1012 may also be referred to as a posterior stabilizing tibial insert (or “PS insert”).

[0080] FIGS. 16A-16D show the PS insert 1012 of FIGS. 15 and 14 in isolation. The PS insert 1012 may include a fixation side 1020, which may be an inferior side, opposite an articulation side 1022, which may be a superior side. The articulation side 1022 may include a medial articulation portion 1024 having a medial condylar articulation surface 1025 and a lateral articulation portion 1026 having a lateral condylar articulation surface 1027. A central portion 1028 may separate the medial articulation portion 1024 from the lateral articulation portion 1026. A post 1030 may protrude superiorly from the central portion 1028 and extend from a post base 1038 to a post top 1040 or post superior end. From the anterior perspective (shown in FIG. 16B) and/or the posterior perspective (shown in FIG. 16A), the post 1030 may have its maximum medial-lateral or horizontal width toward the top 1040 of the post 1030, and its minimum medial-lateral or horizontal width toward the base 1038 of the post 1030. The post 1030 may also be bilaterally symmetrical from the anterior and/or posterior perspectives. A recess 1045 may be formed posterior to the central portion 1028, between the medial and lateral articulation portions 1024, 1026, and may provide room for a posterior cruciate ligament (not shown). The PS insert 1012 may further include an insert base 1046, which may further include an engagement feature 1048 for engagement with a tibial baseplate component.

[0081] Continuing with FIGS. 14-16D, the post 1030 may have an articulation surface 1031 extending around the post 1030 on the medial, posterior, lateral, and anterior aspects of the post 1030. The articulation surface 1031 may include a medial articulation surface 1032, a lateral articulation surface 1034, an anterior post surface 1036, and a posterior articulation surface 1042. The medial and lateral articulation surfaces 1032, 1034 may be non-parallel to one another and taper inward from the post superior end 1040 to the post base 1038 relative to an insert midline vertical axis 1002, as shown in FIGS. 16A and 16B. As shown in FIG. 16A, an angle  $\theta$  between the vertical axis 1002 and each tapered surface 1032, 1034 may be about 6.5°, in at least one embodiment. Since the post 1030 may be bilaterally symmetrical, the angle  $\theta$  may be the same on both the medial and lateral sides 1032, 1034 of the post 1030. In other embodiments of the disclosure, angle  $\theta$  may range from about 6° to 11° degrees. The medial articulation surface 1032 may be continuous with the medial condylar articulation surface 1025, and the lateral articulation surface 1034 may be continuous with the lateral condylar articulation surface 1027. The anterior post surface 1036 may extend between the medial and lateral surfaces 1032, 1034 and may be convexly rounded. The anterior post surface 1036 may also taper outward from the post superior end 1040 to the post base 38 relative to the insert midline vertical axis 1002, as best seen in FIG. 16D. In other embodiments of the PS insert 1012, the anterior post surface 1036 may include less taper,

more taper, and/or no taper. A midline medial-lateral axis 1004 and a mid-line anterior-posterior axis 1006 are also shown.

[0082] Referring to FIG. 16C, the boundary of the superior end 1040 may define a rounded rim 1044 shaped as a portion of a circle defined by a circular envelope 1047, as seen from a superior perspective. The superior end 1040 and rim 1044 may have a convex protrusion 1041 toward a posterior end of the post 1030 as shown, and may permit passage of the posterior cruciate ligament. The circular superior end 1040 with rim 1044 may provide increased rotational range of motion and surface contact against the femoral component 1014 in comparison to traditional posts with a more square or rectangular shape and no rim. Thus, the rounded superior end 1040 and rim 1044 may allow for greater surface contact with the femoral component 1014 in contrast to the mere point or edge contact that is achieved by traditional posts that do not have these features.

[0083] The PS femoral component 1014 depicted in FIGS. 14-15 may include augment fixation apertures 1080, impact driver apertures 1090, a cam element or cam bar 1050, and a box structure 1052 for providing posterior stabilization in place of absent ligaments. The cam bar 1050 may include a cam articulating surface 1051 which may contact the posterior articulation surface 1042 of the post 1030 during flexion. An internal articulation surface 1054 may reside on the inside of the box structure 1052 and may contact the post 1030 during articulation and rotation of the knee joint. The internal articulating surface 1054 may be concavely curved, and may contact the rim 1044 of the post 1030 during axial rotation of the knee joint about the post 1030. The PS femoral component 1014 may further include a medial condyle 1060 having a medial condylar articulation surface 1062, and a lateral condyle 1064 having a lateral condylar articulation surface 1066. The medial and lateral condylar articulation surfaces 1062, 1066 may articulate against the PS insert 1012 medial and lateral articulation surfaces 1025, 1027 respectively. A gap 1068 may be formed between the medial and lateral condyles 1060, 1064, with the cam bar 1050 extending medial-laterally across the gap 1068. The internal articulation surface 1054 may include a medial portion 1070 continuous with a lateral portion 1072. In the embodiment depicted, a fixation post 1074 may protrude superiorly from the PS femoral component 1014. However, in other embodiments of the PS femoral component 1014, the fixation post 1074 may be absent and/or other fixation features such as posts, spikes, pegs, webs, keels or teeth may be present to affix the PS femoral component 1014 to a prepared femur (not shown).

[0084] Referring to FIGS. 17 and 18, another assembly 1110 embodiment of the disclosure may include the PS insert 1012 of FIGS. 14-16D coupled with a cruciate retaining femoral component 1114 (or “CR femoral component”). The CR femoral component 1114 may include a keel 1120, fixation members 1130, impact driver apertures 1190, and medial and lateral condyles 1160, 1164 with a gap 1168 formed between the condyles 1160, 1164. As a CR femoral component 1114, no cam bar or box may be present. The condyles 1160, 1164 may include medial and lateral condylar articulation surfaces 1162, 1166, and an internal articulation surface 1154 with medial and lateral portions 1170, 1172.

[0085] The tapered sides 1032, 1034 of the post 1030 may permit natural articulation of the CR femoral component

**1114** with the PS insert **1012**, which may not be achievable if the post **1030** were not tapered. For example, if the post **1030** had straight sides instead of tapered sides, the wider width of the post **1030** at the base of the post **1030** may interfere with the internal articulating surfaces **1170**, **1172** of the condyles **1160**, **1164**. When the PS femoral component **1014** is coupled with the PS insert **1012** to form assembly **1010**, as in FIGS. **14** and **15**, the circular shape of the post superior end **1040** in combination with the tapered medial and lateral surfaces **1032**, **1034** of the post **1030**, may permit the PS femoral component **1014** to articulate relative to the PS insert **1012** in the manner of a posterior stabilized femoral component. However, when the PS insert **1012** is paired and implanted with the CR femoral component **1114**, the resultant assembly **1110** may provide the native articulation and rotation of a cruciate retaining implant.

[**0086**] Referring to FIGS. **19** and **20**, another assembly **2110** embodiment of the disclosure may include the PS insert **1012** of FIGS. **14-16D** coupled with a cruciate retaining femoral component **2114** (or “CR femoral component”). The CR femoral component **2114** may not include a keel, as opposed to the CR femoral component **1114** shown in FIGS. **17** and **18**, and the CR femoral component **2114** may be configured for cemented and/or cementless fixation to a femoral bone. The CR femoral component **2114** may include fixation members **2130**, impact driver apertures **2190**, and medial and lateral condyles **2160**, **2164** with a gap **2168** formed between the condyles **2160**, **2164**. As a CR femoral component **2114**, no cam bar or box may be present. The condyles **2160**, **2164** may include medial and lateral condylar articulation surfaces **2162**, **2166**, and an internal articulation surface **2154** with medial and lateral portions **2170**, **2172**.

[**0087**] The tapered sides **1032**, **1034** of the post **1030** may permit natural articulation of the CR femoral component **2114** with the PS insert **1012**, which may not be achievable if the post **1030** were not tapered. For example, if the post **1030** had straight sides instead of tapered sides, the wider width of the post **1030** at the base **1038** of the post **1030** may interfere with the internal articulating surfaces **2170**, **2172** of the condyles **2160**, **2164**. When the PS femoral component **1014** is coupled with the PS insert **1012** to form assembly **1010**, as in FIGS. **14** and **15**, the circular shape of the post superior end **1040** in combination with the tapered medial and lateral surfaces **1032**, **1034** of the post **1030**, may permit the PS femoral component **1014** to articulate relative to the PS insert **1012** in the manner of a posterior stabilized femoral component. However, when the PS insert **1012** is paired and implanted with the CR femoral component **2114**, the resultant assembly **2110** may provide the native articulation and rotation of a cruciate retaining implant.

[**0088**] Referring to FIGS. **21A-21E**, an alternative embodiment of a tibial insert **1212** is shown. The tibial insert **1212** may be referred to as a cruciate retaining tibial insert **1212** (or “CR insert”). In a system of the disclosure, the CR insert **1212** may be implanted with the CR femoral components **114**, **1114**, **2114** and a tibial baseplate component (not shown) to form a cruciate retaining knee prosthesis system. The CR insert **1212** may include a fixation side **1220**, which may be an inferior side, opposite an articulation side **1222**, which may be a superior side. The articulation side **1222** may include a medial articulation portion **1224** having a medial condylar articulation surface **1225** and a lateral articulation portion **1226** having a lateral condylar articula-

tion surface **1227**. A central portion **1228** may separate the medial articulation portion **1224** from the lateral articulation portion **1226**. A recess **1245** may be formed posterior to the central portion **1228**, between the medial and lateral articulation portions **1224**, **1226**, and may provide room for a posterior cruciate ligament. The CR insert **1212** may further include an insert base **1246** and an engagement feature **1248** for engagement with a tibial baseplate component.

[**0089**] The CR insert **1212** may be coupled with CR femoral components **114**, **1114**, **2114** to form a cruciate retaining assembly. This cruciate retaining assembly may be implanted with a suitable tibial baseplate as a complete cruciate retaining knee prosthesis. The CR insert **1212** may also be coupled with PS femoral components **14**, **1014** to form a posterior stabilizing assembly and implanted with a suitable tibial baseplate as a complete posterior stabilizing knee prosthesis.

[**0090**] Referring to FIGS. **22A-22F**, another alternative embodiment of a tibial insert **1312** is shown. The tibial insert **1312** may be referred to as a constrained condylar knee (CCK) tibial insert **1312** (or “CCK insert”). The CCK insert **1312** may include a fixation side **1320**, which may be an inferior side, opposite an articulation side **1322**, which may be a superior side. The articulation side **1322** may include a medial articulation portion **1324** having a medial condylar articulation surface **1325** and a lateral articulation portion **1326** having a lateral condylar articulation surface **1327**. A central portion **1328** may separate the medial articulation portion **1324** from the lateral articulation portion **1326**. A post **1330** may protrude superiorly from the central portion **1328**, and extend from a post base **1338** to a top, or post superior end **1340**. From the anterior perspective, as shown in FIG. **22E**, and the posterior perspective, as shown in FIG. **22D**, the post **1330** may have its maximum medial-lateral or horizontal width at the post superior end **1340** of the post **1330**, and its minimum medial-lateral or horizontal width at the post base **1338** of the post **1330**. The post **1330** may be bilaterally symmetrical from the anterior and posterior perspectives. The CCK insert **1312** may further include a posterior recess **1345**, an insert base **1346**, and an engagement feature **1348** for engagement with a tibial tray (not shown). An opening **1350** may be present in the superior surface of the post **1330**.

[**0091**] The post **1330** may have an articulation surface **1331** extending around the post **1330** on the medial, posterior, lateral, and anterior aspects of the post **1330**. The articulation surface **1331** may include a medial articulation surface **1332**, a lateral articulation surface **1334**, an anterior post surface **1336**, and a posterior articulation surface **1342**. The medial and lateral articulation surfaces **1332**, **1334** may taper slightly inward from the post superior end **1340** to the post base **1338** of the post **1330** relative to an insert midline vertical axis **1302**. However, some embodiments of CCK insert **1312** may include less taper, more taper, and/or no taper of the medial and lateral articulation surfaces **1332**, **1334**. The medial articulation surface **1332** may be continuous with the medial condylar articulation surface **1325**, and the lateral articulation surface **1334** may be continuous with the lateral condylar articulation surface **1327**. The anterior post surface **1336** may extend between the medial and lateral articulation surfaces **1332**, **1334** and may be convexly rounded. The anterior post surface **1336** may taper outward from the post superior end **1340** to the post base **1338** relative to the midline axis **1302**, as best seen in FIG. **22F**.

In other embodiments of the CCK insert **1312**, the anterior post surface **1336** may include less taper, more taper, and/or no taper. The post **1330** of the CCK insert **1312** may be wider and bigger in diameter than the post **30** of PS insert **12**, for example to provide increased stability in the case of removal of the collateral ligaments. A midline medial-lateral axis **1304** and a mid-line anterior-posterior axis **1306** are also shown in FIGS. **22D** through **22F**.

[**0092**] Referring to FIG. **22B**, the boundary of the post superior end **1340** may define a rounded rim **1344** shaped as a portion of a circle, from a superior perspective, and may have a convex protrusion toward a posterior end of the post **1330**. The post superior end **1340** and rim **1344** may be semi-circular as shown, however the rim **1344** may define a circular envelope **1347**. The post superior end **1340** may be circular and the rim **1344** may provide increased surface contact and rotational range of motion when coupled and implanted with the PS femoral components disclosed herein in comparison to traditionally shaped posts with a more square or rectangular shaped post. Thus, the rounded post superior end **1340** and rim **1344** may allow for greater surface contact with the femoral components **14**, **1014** in contrast to the mere point or edge contact that is achieved by traditional posts that do not include these features.

[**0093**] The CCK insert **1312** may be coupled with the PS femoral components **14**, **1014** to form a constrained condylar knee assembly, and this assembly may be implanted with a suitable tibial baseplate as a constrained condylar knee prosthesis. The CCK insert **1312** may also be coupled with any of the CR femoral components disclosed herein and implanted with a suitable tibial baseplate. Thus, all of the tibial inserts disclosed herein are interchangeable with all of the CR and PS femoral components disclosed herein.

[**0094**] Any of the tibial inserts, CR femoral components, and/or PS femoral components disclosed herein may be grouped together in any number or combination as one or more modular knee replacement systems or kits. A particular kit may include a CR femoral component, a PS insert, and a CR insert. Yet another particular kit may include a PS femoral component, a PS insert, a CR insert, and a CCK insert. Suitable tibial baseplate components may also be included with any kit. Moreover, any of the tibial inserts disclosed herein may be formed of vitamin E polyethylene, highly cross linked polyethylene, ultra-high molecular weight polyethylene (UHMWPE), and/or the like.

[**0095**] In an example method of the disclosure, a patient may initially experience compromise of the anterior cruciate ligament. The ACL may be removed, and a CR type prosthesis may be implanted, including a CR femoral component, a CR insert, and a tibial baseplate component. Later, the same patient may experience compromise of the PCL and may need additional stabilization of the knee joint. The PCL may be removed, the CR tibial insert may be removed, and a PS tibial insert of the disclosure may be inserted between the originally implanted CR femoral component and the tibial baseplate component, thus providing additional stability for the missing PCL. Even later, the same patient may experience instability of the collateral ligaments. The PS tibial insert may be removed, and the CCK tibial insert of the disclosure may be inserted between the originally implanted CR femoral component and the tibial baseplate component. Thus, the patient may progress from a CR knee prosthesis, to a PS knee prosthesis, and finally to a CCK knee prosthesis without requiring replacement of the

originally implanted femoral and/or tibial baseplate components. The interchangeability of the inserts permits replacement of only the tibial insert component in order to provide increasing levels of support and stability to the knee joint.

[**0096**] In another example method of the disclosure, a patient may initially experience compromise of both the ACL and the PCL. These ligaments may be removed, and a PS type prosthesis may be implanted, including a PS femoral component, a PS insert, and a tibial baseplate component. Later, the same patient may experience instability of the collateral ligaments. The PS insert may be removed, and a CCK insert may be inserted between the originally implanted PS femoral component and the tibial baseplate component. Thus, the patient may progress from a PS knee prosthesis to a CCK knee prosthesis without requiring replacement of the originally implanted PS femoral component and tibial baseplate component.

[**0097**] Referring now to FIGS. **23A-B**, FIG. **23A** is a perspective front view of the femoral component **1014** of FIG. **14** coupled to one or more augments **1082**, **1084** of the present disclosure and FIG. **23B** is a medial side view of the femoral component **1014** of FIG. **23A**. As briefly mentioned above with reference to FIGS. **14** and **15**, the femoral component **1014** may include augment fixation apertures **1080** that may be configured to secure the one or more augments **1082**, **1084** to the femoral component **1014**, as well as impact driver apertures **1090** configured to receive a femoral component impact driver tool (not shown) to allow a surgeon to press fit the femoral component **1014** to the end of a prepared femur. The augments **1082**, **1084** may be secured to the femoral component **1014** with fixation members **1086** and the augments **1082**, **1084** may generally act to replace missing and/or compromised femoral bone and allow the femoral component **1014** to be adequately secured to a femoral bone under such conditions.

[**0098**] Referring now to FIGS. **24A-H**, a femoral trial component **400** of the disclosure is illustrated in FIGS. **24A-H**. In particular, FIG. **24A** shows a perspective top view of a femoral trial component of the disclosure, FIG. **24B** shows a perspective rear view of the femoral trial component of FIG. **24A**, FIG. **24C** shows a lateral side view of the femoral trial component of FIG. **24A**, FIG. **24D** shows a medial side view of the femoral trial component of FIG. **24A**, FIG. **24E** shows an anterior view of the femoral trial component of FIG. **24A**, FIG. **24F** shows a posterior view of the femoral trial component of FIG. **24A**, FIG. **24G** shows a superior view of the femoral trial component of FIG. **24A**, and FIG. **24H** shows an inferior view of the femoral trial component of FIG. **24A**.

[**0099**] The femoral trial component **400** may be referred to as a universal femoral trial component **400** because the femoral trial component **400** may be used as part of a universal femoral trial system for preparing and trialing a femoral bone of a patient (not shown) to receive a plurality of different femoral implant types, as will be discussed in more detail below. The femoral trial component **400** may include a medial condyle **410** having a medial condylar articulation surface **412**, a lateral condyle **420** having a lateral condylar articulation surface **422**, an attachment aperture **440** located intermediate the medial condyle **410** and the lateral condyle **420**, a patellar projection **430** located anterior to the medial condyle **410** and the lateral condyle **420**, a patellar articulation surface **432**, fixation member drill apertures **470**, impact driver apertures **480**, medial attach-

ment features **450** proximate the medial condyle **410**, and lateral attachment features **460** proximate the lateral condyle **420**. The medial attachment features **450** may further include a medial attachment projection **452**, a medial attachment aperture **454** formed within the medial attachment projection **452**, and a medial attachment recess **456**. The lateral attachment features **460** may likewise include a lateral attachment projection **462**, a lateral attachment aperture **464** formed within the lateral attachment projection **462**, and a lateral attachment recess **466**.

[**0100**] In practice, the femoral trial component **400** may be coupled to a partially prepared distal end of a femur (not shown). For example, a partially prepared distal end of a femur may include five distal cuts that are made to the distal end of the femur using standard techniques and tools (not shown) that are well known in the art. These five cuts may be made to correspond in both shape and angle to the five surfaces on the inner portion of the femoral trial component **400**, as best seen in FIGS. **24C** and **24D**. The femoral trial component **400** may then be press fit onto the partially prepared distal end of the femur and the femoral trial component **400** may also be aligned relative to the distal end of the femur in the medial-lateral directions. The femoral trial component **400** may then be used to further prepare the distal end of the femur and/or perform one or more trial operations with the femoral trial component **400** still in place on the distal end of a femur.

[**0101**] For example, the attachment aperture **440** formed in the femoral trial component **400**, along with the medial and lateral attachment features **450**, **460**, may be configured to receive any of a plurality of removably couplable femoral bone preparation attachments and/or any of a plurality of femoral trial attachments. Example femoral bone preparation attachments may include a posterior stabilizing notch cutting guide assembly **500**, an augment cutting guide assembly (not shown), and a drill and broach guide assembly **700**, as will be discussed in more detail below. Each of these femoral bone preparation attachments may be configured to removably couple to the universal femoral trial component **400** to allow a femoral bone of a patient to be selectively modified and prepared to receive a selected femoral implant type. Example femoral trial attachments may include a cruciate retaining trial attachment **800** including a cruciate retaining central portion articulation surface **810** and a posterior stabilizing trial attachment **600** including a posterior stabilizing central portion articulation surface **610**, as will be discussed in more detail below. The cruciate retaining trial attachment **800** and the posterior stabilizing trial attachment **600** may each be configured to removably couple to the universal femoral trial component **400** to provide a central portion articulation surface **610**, **810** above the attachment aperture **440** and allow for trialing of an articulation surface for a selected femoral implant type that includes a medial condylar articulation surface, a lateral condylar articulation surface, and a central portion articulation surface, for the selected femoral implant type. In this manner, the femoral bone preparation attachments and the femoral trial attachments may be used to help finish preparing the femur of the patient to receive any type of femoral component disclosed herein, and/or further perform one or more trial operations with the femoral trial component **400** still in place on the femur, as will be discussed in more detail below.

[**0102**] The femoral trial component **400** shown in FIGS. **24A-H** is a right side femoral trial component **400** having a patellar projection **430** with a right angled medial-lateral shape, as best seen in FIGS. **24E** and **24F**, which mimics the patellar region of a right femur (not shown). Note how the patellar projection **430** angles towards the right in the posterior view of the femoral trial component **400** shown in FIG. **24F** and towards the left in the anterior view of the femoral trial component **400** shown in FIG. **24E**. A left side femoral trial component (not shown) will have a patellar projection **430** shape that is a mirror image of that shown in FIGS. **24E** and **24F**, having a left angled medial-lateral shape that mimics the patellar region of a left femur (not shown). In another embodiment of the disclosure illustrated in FIGS. **35A-C**, a universal femoral trial component **900** may include a patellar projection **910** with a universal shape that does not angle towards the right or left, but rather, the patellar projection **910** in this embodiment may have a symmetrical medial-lateral shape. In this manner, the universal femoral trial component **900** shown in FIGS. **35A-C** has a universal shape that may be used to prepare and trial both right and left side femurs. The patellar projection **910** may have a patellar articular surface **912**.

[**0103**] FIGS. **25A-26** illustrate a posterior stabilizing notch cutting guide assembly **500** that may be used with the femoral trial component **400** shown in FIGS. **24A-H** to help prepare a femur of a patient to receive a PS femoral component of the present disclosure by guiding bone resection. In particular, FIG. **25A** is a perspective rear view of the posterior stabilizing notch cutting guide assembly **500**, FIG. **25B** is another perspective rear view of the posterior stabilizing notch cutting guide assembly **500**, FIG. **25C** is a medial side view of the posterior stabilizing notch cutting guide assembly **500**, FIG. **25D** is a top view of the posterior stabilizing notch cutting guide assembly **500**, and FIG. **26** is a partial exploded view of the posterior stabilizing notch cutting guide assembly **500**.

[**0104**] The posterior stabilizing notch cutting guide assembly **500** may include a posterior stabilizing notch cutting guide body **510** that includes a medial member **520** having a medial cutting guide surface **522** and medial channels **524** formed therein, a lateral member **530** having a lateral cutting guide surface **532** and lateral channels **534** formed therein, and a patellar member **540** having a patellar cutting guide surface **542**.

[**0105**] The posterior stabilizing notch cutting guide assembly **500** may also include a locking mechanism which may include: a first locking member **552**, a second locking member **554**, a first release lever **562** coupled to the first locking member **552** via a first pin **572**, a second release lever **564** coupled to the second locking member **554** via a second pin **574**, a first resilient member **592** located between the first release lever **562** and the posterior stabilizing notch cutting guide body **510**, with the first resilient member **592** housed in a first resilient member housing **582**, a second resilient member (not shown) similarly located between the second release lever **564** and the posterior stabilizing notch cutting guide body **510**, with the second resilient member housed in a second resilient member housing **584**.

[**0106**] The first resilient member **592** may be configured to apply a biasing force that acts to push the first locking member **552** away from the posterior stabilizing notch cutting guide body **510** in the medial direction and the second resilient member may be configured to apply a



biasing force that acts to push the second locking member **554** away from the posterior stabilizing notch cutting guide body **510** in the lateral direction.

[0107] Referring to FIGS. **27A** and **27B**, the posterior stabilizing notch cutting guide assembly **500** may be removably coupled to the universal femoral trial component **400** by squeezing the first release lever **562** and the second release lever **564** together toward each other (see arrows **501** in FIG. **27A**) in order to overcome the biasing forces of the first resilient member **592** and the second resilient member; then inserting the posterior stabilizing notch cutting guide assembly **500** into the attachment aperture **440** of the universal femoral trial component **400** (see arrow **502** in FIG. **27A**); and finally releasing the first release lever **562** and the second release lever **564** to allow the biasing forces of the first resilient member **592** and the second resilient member to push the first locking member **552** and the second locking member **554** away from the posterior stabilizing notch cutting guide body **510**, causing the first locking member **552** to enter within the medial attachment aperture **454** of the femoral trial component **400** and the second locking member **554** to enter within the lateral attachment aperture **464** of the femoral trial component **400** to couple the posterior stabilizing notch cutting guide assembly **500** to the universal femoral trial component **400**, as shown in FIG. **27B**.

[0108] FIGS. **28A-D** illustrate a posterior stabilizing trial attachment **600** that may be used with the femoral trial component **400** shown in FIGS. **24A-H** to aid performance of one or more trial operations with the femoral trial component **400** in place on the distal end of the femoral bone. In particular, FIG. **28A** is a perspective rear view of the posterior stabilizing trial attachment **600**, FIG. **28B** is another perspective rear view of the posterior stabilizing trial attachment **600**, FIG. **28C** is a perspective front view of the posterior stabilizing trial attachment **600**, and FIG. **28D** is a perspective side view of the posterior stabilizing trial attachment **600**.

[0109] The posterior stabilizing trial attachment **600** may include a central portion articulation surface **610**, an internal articulation surface **620** having a medial portion **622** and a lateral portion **624**, a cam bar element **630** having a cam bar articulating surface **632**, a posterior stabilizing box **670**, and a gap **640** formed between the medial and lateral portions **622**, **624** within the posterior stabilizing box **670**. Each of these components of the posterior stabilizing trial attachment **600**, such as the posterior stabilizing box **670** and the cam bar element **630**, may be configured to allow for trialing of a complete posterior stabilizing femoral implant.

[0110] The posterior stabilizing trial attachment **600** may also include attachment projections **650**, **660** on the medial and lateral sides of the posterior stabilizing trial attachment **600**. The attachment projections **650**, **660** may have shapes that are complementary to the medial and lateral attachment features **450**, **460** and/or the medial and lateral attachment recesses **456**, **466** that are formed in the femoral trial component **400**. In this manner, the attachment projections **650**, **660** may be configured to couple to the medial and lateral attachment features **450**, **460** and/or the medial and lateral attachment recesses **456**, **466** formed in the femoral trial component **400**, as shown in FIGS. **29A** and **29B**. This may be accomplished by holding the posterior stabilizing trial attachment **600** above the femoral trial component **400** and moving the posterior stabilizing trial attachment **600**

toward the attachment aperture **440** formed in the universal femoral trial component **400** (see arrow **601** in FIG. **29A**) until the posterior stabilizing trial attachment **600** is coupled to the femoral trial component **400**, as shown in FIG. **29B**. In at least one embodiment, the posterior stabilizing trial attachment **600** may be further configured to magnetically couple to the femoral trial component **400**.

[0111] In this manner, the posterior stabilizing trial attachment **600** may removably couple to the universal femoral trial component **400** and provide the central portion articulation surface **610** above the attachment aperture **440** of the femoral trial component **400** to allow for trialing of a complete articulation surface for a selected femoral implant type, such as a PS femoral component disclosed herein. A complete articulation surface may include a medial condylar articulation surface, a lateral condylar articulation surface, and the central portion articulation surface **610**, for the selected femoral implant type.

[0112] FIGS. **30A-31** illustrate a drill and broach guide assembly **700** that may be used with the femoral trial component **400** shown in FIGS. **24A-H** to help prepare a femur of a patient to receive a femoral component of the present disclosure that utilizes a keel or other bone fixation member that may require a pre-drilled and/or broached bone aperture. In particular, FIG. **30A** is a perspective rear view of the drill and broach guide assembly **700**, FIG. **30B** is a perspective bottom view of the drill and broach guide assembly **700**, FIG. **30C** is a top view of the drill and broach guide assembly **700**, FIG. **30D** is a bottom view of the drill and broach guide assembly **700**, and FIG. **31** is a partial exploded view of the drill and broach guide assembly **700**.

[0113] The drill and broach guide assembly **700** may include a drill and broach guide body **710**, attachment projections **750**, **760**, and a drill and broach guide **720**. The drill and broach guide **720** may further include a first drill guide aperture **721**, a second drill guide aperture **722**, a third drill guide aperture **723**, a first broach guide aperture **725** intermediate the first drill guide aperture **721** and the second drill guide aperture **722**, and a second broach guide aperture **726** intermediate the second drill guide aperture **722** and the third drill guide aperture **723**. The second drill guide aperture **722** may also be located intermediate the first broach guide aperture **725** and the second broach guide aperture **726**.

[0114] The drill and broach guide assembly **700** may also include a drill and broach guide locking mechanism which may include: a first locking member **742**, a second locking member **744**, a first release lever **732** coupled to the first locking member **742** via a first pin **752**, a second release lever **734** coupled to the second locking member **744** via a second pin **754**, and a resilient member **770** located between the first locking member **742** and the second locking member **744** within a locking member housing **780** formed within the drill and broach guide body **710**. The resilient member **770** may be configured to apply a biasing force between the first locking member **742** and the second locking member **744** to push the first locking member **742** and the second locking member **744** away from each other.

[0115] Referring to FIGS. **32A** and **32B**, the drill and broach guide assembly **700** may be removably coupled to the universal femoral trial component **400** by squeezing the first release lever **732**, and the second release lever **734** together toward each other (see arrows **701** in FIG. **32A**) in order to overcome the biasing force of the resilient member

770 between the first locking member 742 and the second locking member 744; then inserting the drill and broach guide assembly 700 into the attachment aperture 440 formed in the universal femoral trial component 400 (see arrow 702 in FIG. 32A); and finally releasing the first release lever 732 and the second release lever 734 to allow the biasing force of the resilient member 770 to push the first locking member 742 and the second locking member 744 away from each other, causing the first locking member 742 to enter within the medial attachment aperture 454 of the femoral trial component 400 and the second locking member 744 to enter within the lateral attachment aperture 464 of the femoral trial component 400 to couple the drill and broach guide assembly 700 to the universal femoral trial component 400, as shown in FIG. 32B. The attachment projections 750, 760 may also have shapes that are complementary to the medial and lateral attachment features 450, 460 and/or the medial and lateral attachment recesses 456, 466 formed in the femoral trial component 400 to aid coupling of the drill and broach guide assembly 700 to the universal femoral trial component 400, as well as magnetic coupling capabilities.

[0116] FIGS. 40-44 illustrate an embodiment of a drill and broach guide assembly 1790 that may be used with the femoral trial component 400 shown in FIGS. 24A-H to help prepare a femur of a patient to receive a femoral component of the present disclosure that utilizes a keep or other bone fixation member, which may require a pre-drilled and/or broached bone aperture. In particular, FIG. 40 is a perspective view of the drill and broach guide assembly 1790, FIG. 41 is a side perspective view of the drill and broach guide assembly 1790, FIG. 42 is a bottom view of the drill and broach guide assembly 1790, FIG. 43 is a partial exploded view of the drill and broach guide assembly 1790, and FIG. 44 is a partial exploded bottom perspective of the drill and broach guide assembly 1790.

[0117] The drill and broach guide assembly 1790 may include a drill and broach guide body 1710, attachment projections 1760 on opposing sides of the body 1710, and a drill and broach guide 1720. The drill and broach guide 1720 may further include a first drill guide aperture 1721, a second drill guide aperture 1722, a third drill guide aperture 1723, a first broach guide aperture 1725 intermediate the first drill guide aperture 1721 and the second drill guide aperture 1722, and a second broach guide aperture 1726 intermediate the second drill guide aperture 1722 and the third drill guide aperture 1723. The second drill guide aperture 1722 may also be located intermediate the first broach guide aperture 1725 and the second broach guide aperture 1726.

[0118] The drill and broach guide assembly 1790 may also include a drill and broach guide locking mechanism. The locking mechanism may include a handle 1700, with a grip 1701, a base 1702, a track 1703, and a handle tab connection 1704. The handle 1700 fits within a cavity 1770 in the body 1710 of the drill and broach guide, so that the handle tab connections pass into the cavity 1770 and the base 1702 may rest on the body 1710. The handle is attached to the body 1710 via pins 1711. The handle is operationally connected to a first tab 1740 and a second tab 1741. The first tab 1740 and the second tab 1741 are extendable from the base 1710 on opposing sides, as illustrated in FIGS. 40 and 41.

[0119] As illustrated in FIG. 42, the handle tab connection 1704 is visible in the cavity 1770, in a bottom of the base 1710. The handle tab connection 1704 is shown as two

protrusions from the base 1702 of the handle 1700, which engage tab apertures 1746 in the first tab 1740 and the second tab 1741. However, it is understood that the handle tab connection 1704 may be any reasonable operational connection between the handle 1700 and the first tab 1740 and the second tab 1741. Other operational connections may include protrusions on the first tab 1740 and the second tab 1741, which engage with apertures on the handle 1700. Operational connections may include belt or screw drives, or any combination of bosses, bushings, or other bearing surfaces. The handle tab connection 1704 engages and passes through proximal ends 1744 of the first tab 1740 and the second tab 1741. A portion of the handle tab connections 1704, passing through and protruding through the proximal ends 1744 of the first tab 1740 and the second tab 1741, may engage rotation stops 1750 on the body 1710 at the edge of the cavity 1770. The rotation stops 1750 oppose one another across the cavity 1770, and are configured to limit the movement of the handle tab connection 1704 about an axis that passes through the cavity 1770. The rotation stops 1750 are illustrated as bumps or protrusions but may have any structural configuration that limits movement of the handle 1700 about the axis.

[0120] The first tab 1740 and the second tab 1741 each have a proximal end 1744, which is engaged with the handle 1700 as discussed above, a distal end 1743, and a compressible section 1745 connecting the proximal end 1744 and the distal end 1743. The first tab 1740 and the second tab 1741 are located within the body 1710 of the guide assembly 1790, so that the proximal ends 1744 are nearest the cavity 1770 and the distal ends 1743 extend away from the cavity 1770, as shown in FIG. 42. The compressible sections 1745 are depicted having spring-like configurations, but may have coiled or other resilient configurations.

[0121] FIGS. 43 and 44 illustrate more fully how the drill and broach guide 1790 is operationally connected. The handle 1700 may rotate relative to the body 1710 about the axis that passes through the cavity 1770. The handle 1700 is secured to the body 1710 via an engagement between pins 1711, the body 1710, and the track 1703 of the handle 1700. The pins 1711 each comprise a threaded section 1712 and a smooth section 1713. The pins 1711 are configured to screw into pin holes 1714 in the body 1710. The threaded sections 1712 engage with complementary threaded portions of the pin holes 1714. When threaded in the pin holes 1744, the smooth sections 1713 of the pins 1711 extend into the cavity 1770. When the base 1702 of the handle 1700 is seated on the body 1710, the track 1703 extends into the cavity 1770 and engages the smooth sections 1713 of the pins 1711. The track 1703 and the smooth sections 1713 have complementary profiles, for example the track 1703 is concave and the smooth sections 1713 are convex, which rest in the track 1703. The smooth sections 1713 engage with opposite sides of the track, which fixes the handle 1700 to the body 1710, yet allows the handle 1700 to rotate about the axis.

[0122] The rotation of the handle 1700, while operationally secured to the body 1710, creates a camming action causing the first tab 1740 and the second tab 1741 to extend from or retract into corresponding tab recesses 1771 in opposing sides of the body 1710. As the handle 1710 is turned, the handle tab connections 1704 act on the proximal ends 1744 of the first tab 1740 and second tab 1741 pushing the tabs 1740 1741 out of the body 1710. The protruding portions of the handle tab connections 1704 about the rotation

stops 1750 preventing the handle from a complete rotation. The drill and broach guide assembly 1790 may be configured so that the handle tab connections 1704 about the rotation stops 1750 when the first tab 1740 and the second tab 1741 are at a most-extended position, away from the body. The compressible section 1745 of the first tab 1740 and the second tab 1741 may be configured to apply a biasing force between the distal ends 1743 and the proximal ends 1744 ends of each of the tabs 1740 1741 and the handle 1700.

[0123] In operation, the drill and broach guide assembly 1790 may be removably coupled to the universal femoral trial component 400 by inserting the drill and broach guide assembly 1790 into the attachment aperture 440 formed in the universal femoral trial component 400, similar to what is shown in FIG. 32A represented by arrow 702. The attachment projections 1760 may also have shapes that are complementary to the medial and lateral attachment features 450, 460 and/or the medial and lateral attachment recesses 456, 466 formed in the femoral trial component 400 to aid coupling of the drill and broach guide assembly 1790 to the universal femoral trial component 400, as well as magnetic coupling capabilities. Once seated in the trial component, the handle 1700 may be rotated so that the first tab 1740 and the second tab 1741 are extended into the medial attachment aperture 454 and the lateral attachment aperture 464 of the femoral trial component 400. As the tab distal ends 1743 about walls of the attachment apertures 454 464, the compressible sections 1745 begin to compress, creating the biasing force discussed above. The handle 1700 may be turned further so that the handle tab connections 1704 about the rotation stops 1750. The combination of the biasing force from the compressible sections 1745 in the medial attachment aperture 464 and the lateral attachment aperture 465 and the abutment of the handle tab connections against the rotation stops 1750, causes the drill and broach guide assembly to lock in place in the femoral trial component.

[0124] FIGS. 33A-D illustrate a cruciate retaining trial attachment 800 that may be used with the femoral trial component 400 shown in FIGS. 24A-H to aid performance of one or more trial operations with the femoral trial component 400 in place on the distal end of the femoral bone. In particular, FIG. 33A is a perspective front view of the cruciate retaining trial attachment 800, FIG. 33B is a perspective rear view of the cruciate retaining trial attachment 800, FIG. 33C is a perspective bottom view of the cruciate retaining trial attachment 800, and FIG. 33D is a top view of the cruciate retaining trial attachment 800.

[0125] The cruciate retaining trial attachment 800 may include a central portion articulation surface 810, an internal articulation surface 820 having a medial portion 822 and a lateral portion 824, and a gap 840 formed between the medial and lateral portions 822, 824. Each of these components of the cruciate retaining trial attachment 800 may be configured to allow for trialing of a complete cruciate retaining femoral implant.

[0126] The cruciate retaining trial attachment 800 may also include attachment projections 850, 860 on the medial and lateral sides of the cruciate retaining trial attachment 800. The attachment projections 850, 860 may have shapes that are complementary to the medial and lateral attachment features 450, 460 and/or the medial and lateral attachment recesses 456, 466 that are formed in the femoral trial component 400. In this manner, the attachment projections

850, 860 may be configured to couple to the medial and lateral attachment features 450, 460 and/or the medial and lateral attachment recesses 456, 466 formed in the femoral trial component 400, as shown in FIGS. 34A and 34B. This may be accomplished by holding the cruciate retaining trial attachment 800 above the femoral trial component 400 and moving the cruciate retaining trial attachment 800 toward the attachment aperture 440 formed in the universal femoral trial component 400 (see arrow 801 in FIG. 34A) until the cruciate retaining trial attachment 800 is coupled to the femoral trial component 400, as shown in FIG. 34B. In at least one embodiment, the cruciate retaining trial attachment 800 may be further configured to magnetically couple to the femoral trial component 400.

[0127] In this manner, the cruciate retaining trial attachment 800 may removably couple to the universal femoral trial component 400 and provide the central portion articulation surface 810 above the attachment aperture 440 of the femoral trial component 400 to allow for trialing of a complete articulation surface for a selected femoral implant type, such as a CR femoral component disclosed herein. A complete articulation surface may include a medial condylar articulation surface, a lateral condylar articulation surface, and the central portion articulation surface 810, for the selected femoral implant type.

[0128] Any of the components disclosed herein may be included in a modular universal femoral trial kit (not shown) to aid in preparing and trialing a femoral bone of a patient to receive a plurality of different femoral implant types. In at least one embodiment, the modular universal femoral trial kit may include a container (not shown) that contains a femoral trial component 400, 900 and at least one femoral bone preparation attachment, such as the posterior stabilizing notch cutting guide assembly 500 and/or the drill and broach guide assembly 700, as one non-limiting example. In other embodiments, the modular universal femoral trial kit may also include at least one femoral trial attachment, such as the cruciate retaining trial attachment 800 and/or the posterior stabilizing trial attachment 600, as another non-limiting example.

[0129] FIG. 36 illustrates a flow chart diagram of a method 3000 for preparing and trialing a femoral bone with a universal femoral trial component 400, 900, according to one embodiment of the present disclosure. The method 3000 will be described in connection with the components and instrumentation described herein. However, those of skill in the art will recognize that alternative implants, assemblies, systems, and instrumentation may be used in the performance of the method 3000.

[0130] The method 3000 may begin with a step 3010 in which a universal femoral trial component 400, 900 may be placed on an inferior or distal end of a femoral bone. The distal end of the femoral bone may first be partially prepared with five distal cuts that are made to the distal end of the femur using standard techniques and tools (not shown) that are well known in the art. These five cuts may be made to correspond in both shape and angle to the five surfaces on the inner portion of the universal femoral trial component 400, 900 (e.g., see FIGS. 24C and 24D). The universal femoral trial component 400, 900 may then be press fit onto the partially prepared distal end of the femur.

[0131] In a step 3020, the universal femoral trial component 400, 900 may be further aligned with respect to the femoral bone along a medial-lateral direction in order to

place the universal femoral trial component **400, 900** at a desired medial-lateral location with respect to the femoral bone.

**[0132]** In a step **3030**, one of a plurality of femoral bone preparation attachments may be selected in order to guide resection of portions of the femoral bone, as desired. Example, femoral bone preparation attachments may include the posterior stabilizing notch cutting guide assembly **500** and the drill and broach guide assembly **700**, as two non-limiting examples.

**[0133]** In a step **3040**, the selected femoral bone preparation attachment may be coupled to the universal femoral trial component **400, 900** using techniques described previously herein (e.g., see description related to FIGS. **27A-B** and FIGS. **32A-B**).

**[0134]** In a step **3050**, the femoral bone may be prepared to receive a desired femoral component by using the selected femoral bone preparation attachment as a guide to resect at least a portion of the femoral bone in order to prepare the femoral bone to receive the desired femoral component. Once the femoral bone has been prepared with the selected femoral bone preparation attachment, the method may move to a step **3060**.

**[0135]** In the step **3060**, the selected femoral bone preparation attachment may be removed from the universal femoral trial component **400, 900**.

**[0136]** In a step **3070**, one of a plurality of femoral trial attachments may be selected in preparation for performing one or more trial operations with the universal femoral trial component **400, 900** still in place on the femoral bone.

**[0137]** In a step **3080**, the selected femoral trial attachment may be coupled to the universal femoral trial component **400, 900** using techniques described previously herein (e.g., see description related to FIGS. **29A-B** and FIGS. **34A-B**).

**[0138]** In a step **3090**, at least one trial operation may be performed with the selected femoral trial attachment coupled to the universal femoral trial component **400, 900**, and the method **300** may end. For example, the surgeon may perform trialing of articulation surfaces of the knee joint to ensure that the articulation characteristics of the prosthetic knee joint will be satisfactory.

**[0139]** Various steps of any method disclosed herein may be reordered, omitted, and/or replaced with different steps within the scope of the present disclosure. Those of skill in the art, with the aid of the present disclosure, will recognize that many variations may be made to any other method disclosed herein, depending on the particular surgical procedure to be carried out, as well as the configuration of the system used in the performance of that surgical procedure. Moreover, any methods disclosed herein may include one or more steps or actions for performing the described method. These method steps and/or actions may be interchanged with one another. In other words, unless a specific order of steps or actions is required for proper operation of the embodiment, the order and/or use of specific steps and/or actions may be modified.

**[0140]** FIG. **37** illustrates a flow chart diagram of a method **4000** for revising a knee joint prosthesis implanted in a knee of a patient to provide increased stability to the knee joint prosthesis, according to one embodiment of the present disclosure. The method **4000** will be described in connection with the components and instrumentation described herein. However, those of skill in the art will recognize that alter-

native implants, assemblies, systems, and instrumentation may also be used in the performance of the method **4000**.

**[0141]** The method **4000** may begin with a step **4010**, in which a first knee joint prosthesis that is implanted in a knee of a patient is surgically accessed. The first knee joint prosthesis may comprise a first tibial insert that is located between a tibial base plate component that is implanted on a tibia of the patient and a femoral component that is implanted on a femur of the patient.

**[0142]** The method **4000** may then proceed to a step **4020**, in which the first tibial insert may be removed from between the tibial base plate component and the femoral component.

**[0143]** The method **4000** may then proceed to a step **4030**, in which a second tibial insert may be inserted between the tibial baseplate component and the femoral component to create a second knee joint prosthesis assembly that is more constrained than the first knee joint prosthesis assembly, and the method **4000** may end.

**[0144]** FIGS. **38A-F** and **39** illustrate an example tibial tray **5000** that may be used with any of the tibial inserts and femoral components described herein to create various prosthetic knee assemblies, according to embodiments of the present disclosure. In particular, FIG. **38A** shows a perspective front view of the tibial tray **5000**, FIG. **38B** shows a perspective rear view of the tibial tray **5000**, FIG. **38C** shows an anterior view of the tibial tray **5000**, FIG. **12D** shows a posterior view of the tibial tray, FIG. **38E** shows a bottom view of the tibial tray **5000**, FIG. **38F** shows a top view of the tibial tray **5000**, and FIG. **39** shows an exploded view of an example tibial tray mounting system **6000** that utilizes the tibial tray **5000**.

**[0145]** The tibial tray **5000** may generally include a tibial base plate **5001** that is superiorly mounted on top of a keel **5030**. The tibial base plate **5001** may have a superior end **5010** configured to receive any of the tibial inserts described herein, and an inferior end **5020** configured to engage a superior surface of a prepared tibia of a patient (not shown). The superior end **5010** of the tibial base plate **5001** may include a posterior lip **5012** and an anterior lip **5014**, each configured to couple to and retain any of the tibial inserts described herein. The posterior lip **5012** may have a notch **5016** to permit passage of ligaments and/or other soft tissues. The superior end **5010** of the tibial base plate **5001** may also include a tibial insert retaining aperture **5050** configured to receive a tibial insert retaining rod **6010**, which may be used to further couple to and retain a suitable tibial insert to the tibial base plate **5001**, as shown in FIG. **39**, provided the tibial insert has a corresponding opening in the post of the tibial insert configured to receive the tibial insert retaining rod **6010** (e.g., see the tibial insert shown in FIGS. **22A-F**).

**[0146]** The inferior end **5020** of the tibial base plate **5001** may include one or more spikes **5040** configured to penetrate tibial bone to further couple the tibial base plate **5001** to the superior surface of a prepared tibia. The Keel **5030** may also include a medial fin **5032** and a lateral fin **5034** each configured to penetrate tibial bone and provide additional coupling of the tibial tray **5000** to the tibia. Moreover, in some embodiments the Keel **5030** may also include a tibial stem aperture **5036** configured to receive a tibial stem **6030** and/or a stem adapter member **6020** to further couple the tibial tray **5000** to the tibia of a patient (see FIG. **39**). The tibial stem **6030** may be configured to penetrate and reside

within an intramedullary canal of the tibia to provide increased fixation of the tibial tray **5000** to the tibia.

**[0147]** It will be understood that the tibial tray **5000** and tibial tray mounting system **6000** shown in FIGS. **38A-F** and **39** are merely one example of a tibial tray and tibial tray mounting system that may be used with the tibial inserts and femoral components described in the present disclosure and that other tibial trays and tibial tray mounting systems are also contemplated herein.

**[0148]** Reference throughout this specification to “an embodiment” or “the embodiment” means that a particular feature, structure or characteristic described in connection with that embodiment is included in at least one embodiment. Thus, the quoted phrases, or variations thereof, as recited throughout this specification are not necessarily all referring to the same embodiment.

**[0149]** Similarly, it should be appreciated that in the above description of embodiments, various features are sometimes grouped together in a single embodiment, Figure, or description thereof for the purpose of streamlining the disclosure. This method of disclosure, however, is not to be interpreted as reflecting an intention that any claim require more features than those expressly recited in that claim. Rather, as the following claims reflect, inventive aspects lie in a combination of fewer than all features of any single foregoing disclosed embodiment. Thus, the claims following this Detailed Description are hereby expressly incorporated into this Detailed Description, with each claim standing on its own as a separate embodiment. This disclosure includes all permutations of the independent claims with their dependent claims.

**[0150]** The word “exemplary” is used herein to mean “serving as an example, instance, or illustration.” Any embodiment described herein as “exemplary” is not necessarily to be construed as preferred or advantageous over other embodiments. While the various aspects of the embodiments are presented in drawings, the drawings are not necessarily drawn to scale unless specifically indicated.

**[0151]** Recitation in the claims of the term “first” with respect to a feature or element does not necessarily imply the existence of a second or additional such feature or element. Elements recited in means-plus-function format are intended to be construed in accordance with 35 U.S.C. § 112 Para. 6. It will be apparent to those having skill in the art that changes may be made to the details of the above-described embodiments without departing from the underlying principles set forth herein.

**[0152]** The phrases “connected to,” “coupled to” and “in communication with” refer to any form of interaction between two or more entities, including mechanical, electrical, magnetic, electromagnetic, fluid, and thermal interaction. Two components may be functionally coupled to each other even though they are not in direct contact with each other. The term “abutting” refers to items that are in direct physical contact with each other, although the items may not necessarily be attached together. The phrase “fluid communication” refers to two features that are connected such that a fluid within one feature is able to pass into the other feature.

**[0153]** The Figures may show simplified or partial views, and the dimensions of elements in the Figures may be exaggerated or otherwise not in proportion for clarity. In addition, the singular forms “a,” “an,” and “the” include plural referents unless the context clearly dictates otherwise.

Thus, for example, reference to a terminal includes reference to one or more terminals. In addition, where reference is made to a list of elements (e.g., elements a, b, c), such reference is intended to include any one of the listed elements by itself, any combination of less than all of the listed elements, and/or a combination of all of the listed elements.

**[0154]** The term “substantially” means that the recited characteristic, parameter, or value need not be achieved exactly, but that deviations or variations, including for example, tolerances, measurement error, measurement accuracy limitations and other factors known to those of skill in the art, may occur in amounts that do not preclude the effect the characteristic was intended to provide.

**[0155]** As used herein, the term “proximal”, “top”, “up” or “upwardly” may refer to a location on the device that is closest to the clinician using the device and farthest from the patient in connection with whom the device is used when the device is used in its normal operation. Conversely, the term “distal”, “bottom”, “down” or “downwardly” may refer to a location on the device that is farthest from the clinician using the device and closest to the patient in connection with whom the device is used when the device is used in its normal operation. Moreover, the terms “upper” and “lower”, and “top” and “bottom”, “front” and “rear” may be used as relative terms herein for ease of description and understanding. It is understood that in embodiments of the disclosure, upper and lower entities may be reversed, as may top and bottom, front and rear.

**[0156]** As used herein, the term “in” or “inwardly” refers to a location with respect to the device that, during normal use, is toward the inside of the device. Conversely, as used herein, the term “out” or “outwardly” refers to a location with respect to the device that, during normal use, is toward the outside of the device.

**[0157]** While specific embodiments and applications of the present disclosure have been illustrated and described, it is to be understood that the scope of this disclosure is not limited to the precise configuration and components disclosed herein. Various modifications, changes, and variations which will be apparent to those skilled in the art may be made in the arrangement, operation, and details of the methods and systems of the present disclosure set forth herein without departing from its spirit and scope.

What is claimed is:

1. An assembly for facilitating orthopedic surgery, comprising:

- a body;
- a drill guide connected to the body; and
- an attachment mechanism connected to the body, the attachment mechanism comprising:
  - a first tab;
  - a second tab; and
  - a handle connected to the first and second tabs such that rotation of the handle about an axis causes the first and second tabs to extend outward from the body to secure the body to an external frame secured to a patient.

2. The assembly of claim 1, wherein the drill guide comprises at least one drill guide aperture that extends through the drill guide and through the body.

3. The assembly of claim 2, wherein the drill guide further comprises at least one broach guide aperture that extends through the drill guide and through the body.

4. The assembly of claim 3, wherein the at least one drill guide aperture is in communication with the at least one broach guide aperture.

5. The assembly of claim 1, wherein the first tab and the second tab each comprise a proximal end and a distal end, and wherein the proximal ends of the tabs are adjacent to one another and the distal ends of the tabs extend away from each other.

6. The assembly of claim 5, wherein:

the proximal ends of the tabs each have a handle attachment feature;

wherein the handle further comprises tab attachment features complementary to the handle attachment features on each of the tabs; and

rotation of the handle about the axis causes each of the first tab and the second tab to transition between a retracted position and an extended position, relative to the body.

7. The assembly of claim 6, wherein the proximal ends of the first and second tabs are located within a cavity in the body so that the handle attachment features and/or the tab attachment features extend into the cavity.

8. The assembly of claim 6, wherein:

at least one of the first tab and the second tab further comprises a stop member;

the body further comprises an abutment member;

rotation of the handle causes the stop member to engage the abutment member to retain the at least one of the first tab and the second tab in the extended position.

9. The assembly of claim 1, wherein:

the first and the second tabs each comprise a proximal end, a distal end, and an intermediate section therebetween; and

the intermediate section is compressible such that the proximal end and the distal end are configured to be translatable.

10. The assembly of claim 1, further comprising the external frame;

wherein the external frame is a trial component for joint arthroplasty.

11. The assembly of claim 10, wherein:

the first and the second tabs each comprise a proximal end, a distal end, and an intermediate section therebetween;

the trial component comprises:

a receiving aperture shaped to receive the body; and locking apertures, in communication with the receiving aperture, shaped to receive the distal ends of the first tab and the second tab when the handle is rotated with the body positioned in the receiving aperture.

12. An assembly comprising:

a body;

a drill and broach guide comprising:

a first drill guide aperture;

a second drill guide aperture;

a third drill guide aperture;

a first broach guide aperture intermediate the first drill guide aperture and the second drill guide aperture; and

a second broach guide aperture intermediate the second drill guide aperture and the third drill guide aperture, wherein the second drill guide aperture is intermediate the first broach guide aperture and the second broach guide aperture; and

a locking mechanism comprising:

a handle connected to the body such that the handle is rotatable about an axis;

a first tab having a first proximal end, a first distal end, and a first compressible intermediate section, wherein the first proximal end has a first handle connection feature;

a second tab having a second proximal end, a second distal end, and a second compressible intermediate section, wherein the second proximal end has a second handle connection feature; and

wherein the handle is movably connected to the first handle connection feature and the second handle connection feature such that, rotation of the handle about the axis extends the first and second tabs outward from the body.

13. The assembly of claim 12, wherein the first and second tabs are located within a cavity in the body.

14. The assembly of claim 12, wherein:

at least one of the first tab and the second tab further comprises a stop member;

the body further comprises an abutment member; and

rotation of the handle causes the stop member to engage the abutment member to retain the at least one of the first tab and the second tab in an extended position.

15. The assembly of claim 12 wherein:

the handle further comprises a circular base and a grip portion, the circular base having a concave surface;

the body further comprises an aperture, surrounding the axis, extending from a first surface of the body to a second surface of the body, wherein the circular base engages the aperture; and

the handle is rotatably secured to the base at the aperture by two pins extending into the base proximate an edge of the aperture, so that the pins securely engage the concave surface, allowing the handle to rotate about the axis.

16. The assembly of claim 12, further comprising an external frame;

wherein the external frame is a trial component for joint arthroplasty; and

wherein the trial component comprises:

a receiving aperture shaped to receive the body; and locking apertures, in communication with the receiving aperture, shaped to receive the first and second distal ends of the first tab and the second tab when the handle is rotated with the body positioned in the receiving aperture.

17. An assembly for preparing and trialing a bone to receive an implant, the assembly comprising:

a body;

a drill guide connected to the body; and

an attachment mechanism connected to the body, the attachment mechanism further comprising:

a first tab;

a second tab;

a handle connected to the first and second tabs;

wherein the assembly is configured to be removably coupled to a trial component by:

rotating the handle such that the first tab and the second tab are first in a retracted position;

positioning the assembly adjacent to the trial component, and

rotating the handle such that the first tab and the second tab move to an extended position and engage within corresponding attachment apertures in the trial component.

**18.** The assembly of claim **17**, wherein at least one of the first tab and the second tab further comprises a stop member and the body further comprises an abutment member; rotation of the handle causes the stop member to engage the abutment member to retain the at least one of the first tab and second tab in in the extended position or a retracted position.

**19.** The assembly of claim **18**, wherein:

the first and the second tabs each comprise a proximal end, a distal end, and an intermediate section therebetween;

the handle engages the first tab and the second tab at the proximal ends;

the handle is rotatable to transition the first and second tabs to the extended position so that the distal ends of the first and second tabs enter the corresponding attachment apertures in the trial component; and

the intermediate section is compressible such that, in response to the distal ends abutting a surface, the intermediate section is compressed to urge the stop member against the abutment member and prevents rotation of the handle.

**20.** The assembly of claim **17**, further comprising the trial component, wherein;

the first and the second tabs each comprise a proximal end, a distal end, and an intermediate section therebetween;

the trial component is designed to facilitate joint arthroplasty; and

the trial component comprises:

a receiving aperture shaped to receive the body; and locking apertures, in communication with the receiving aperture, shaped to receive the distal ends of the first tab and the second tab when the handle is rotated with the body positioned in the receiving aperture.

\* \* \* \* \*