

(12) **United States Patent**  
**Nguyen et al.**

(10) **Patent No.:** **US 10,940,024 B2**  
(45) **Date of Patent:** **Mar. 9, 2021**

(54) **UNIVERSAL FEMORAL TRIAL SYSTEM AND METHODS**

(71) Applicant: **Optimotion Implants LLC**, Orlando, FL (US)

(72) Inventors: **Vuong Binh Nguyen**, Windermere, FL (US); **Andrew Rynearson**, Winter Springs, FL (US); **Daniel F. Justin**, Orlando, FL (US); **Dinesh V. Koka**, Winter Springs, FL (US)

(73) Assignee: **Optimotion Implants LLC**, Orlando, FL (US)

(\* ) Notice: Subject to any disclaimer, the term of this patent is extended or adjusted under 35 U.S.C. 154(b) by 50 days.

(21) Appl. No.: **16/046,583**

(22) Filed: **Jul. 26, 2018**

(65) **Prior Publication Data**  
US 2019/0029847 A1 Jan. 31, 2019

**Related U.S. Application Data**

(60) Provisional application No. 62/537,106, filed on Jul. 26, 2017.

(51) **Int. Cl.**  
**A61F 2/46** (2006.01)  
**A61B 17/17** (2006.01)  
(Continued)

(52) **U.S. Cl.**  
CPC ..... **A61F 2/4684** (2013.01); **A61B 17/155** (2013.01); **A61B 17/1735** (2013.01);  
(Continued)

(58) **Field of Classification Search**

CPC .. A61F 2/4684; A61F 2/3859; A61F 2/30734; A61F 2/461; A61F 2/389;

(Continued)

(56) **References Cited**

U.S. PATENT DOCUMENTS

4,257,129 A 3/1981 Volz  
4,293,963 A 10/1981 Gold et al.  
(Continued)

FOREIGN PATENT DOCUMENTS

WO WO90003893 4/1990

OTHER PUBLICATIONS

Reference U, DePuy, Knee Revision Reference Cards, published May 2009 (65 pages).

(Continued)

*Primary Examiner* — Kevin T Truong

*Assistant Examiner* — Tracy L Kamikawa

(74) *Attorney, Agent, or Firm* — David Meibos; Maywood IP Law

(57) **ABSTRACT**

Implant assemblies, systems, kits, and methods for replacing a knee joint may include a universal femoral trial component for preparing and trialing a femoral bone of a patient to receive a plurality of different femoral implant types. The universal femoral trial component may be configured to receive any of a plurality of femoral bone preparation attachments and any of a plurality of femoral trial attachments in order to facilitate the preparation and trialing of the femoral bone to receive the plurality of different femoral implant types.

**17 Claims, 48 Drawing Sheets**

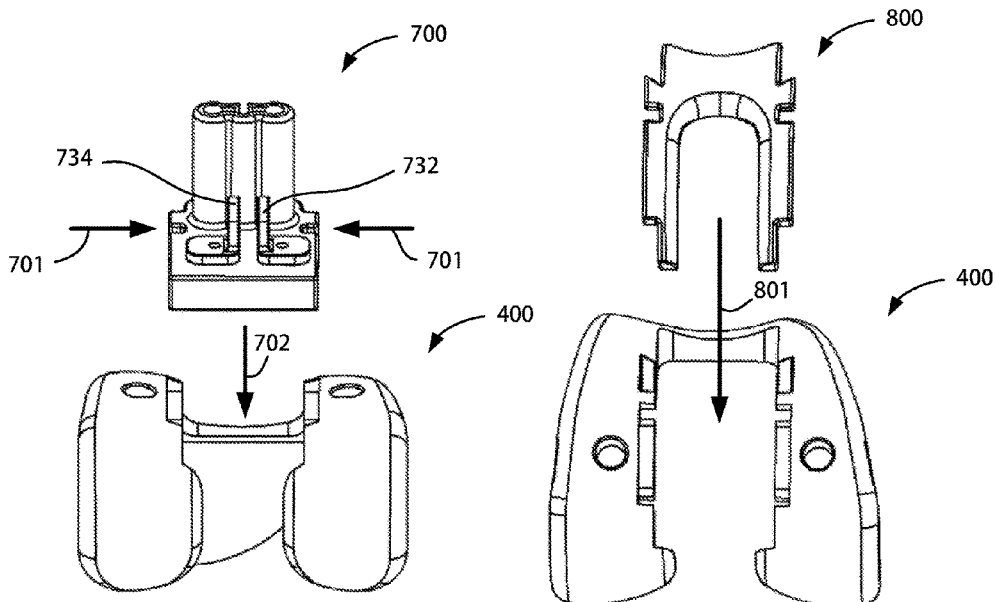



(56)

References Cited

U.S. PATENT DOCUMENTS

9,370,605 B2 6/2016 Zhang et al.  
 9,381,085 B2 7/2016 Axelson, Jr. et al.  
 9,387,084 B2 7/2016 Masini et al.  
 9,402,729 B2 8/2016 Otto et al.  
 9,408,699 B2 8/2016 Stalcup et al.  
 9,445,902 B2 9/2016 Klein et al.  
 9,445,909 B2 9/2016 Cohen et al.  
 9,452,053 B2 9/2016 Wagner et al.  
 9,456,901 B2 10/2016 Jones et al.  
 9,517,134 B2 12/2016 Lang  
 9,539,099 B2 1/2017 Heldreth et al.  
 9,566,161 B2 2/2017 Hartdegen et al.  
 9,579,210 B2 2/2017 Wong  
 9,636,229 B2 5/2017 Lang et al.  
 9,642,711 B2 5/2017 Carson  
 9,649,205 B2 5/2017 Dees, Jr.  
 9,655,728 B2 5/2017 Parisi et al.  
 9,655,729 B2 5/2017 Parisi et al.  
 9,656,358 B2 5/2017 Charlebois et al.  
 9,693,788 B2 7/2017 Metzger  
 9,693,869 B2 7/2017 Salehi et al.  
 9,717,598 B2 8/2017 Otto  
 9,763,794 B2 9/2017 Sanford et al.  
 9,770,345 B2 9/2017 Belcher et al.  
 9,788,954 B2 10/2017 Parisi et al.  
 9,839,522 B2 12/2017 Bechtold et al.  
 9,918,845 B2 3/2018 Roby et al.  
 9,931,216 B2 4/2018 Williams et al.  
 9,937,049 B2 4/2018 Wyss et al.  
 2002/0082741 A1 6/2002 Mazumder et al.

2002/0198529 A1 12/2002 Masini  
 2004/0039395 A1 2/2004 Coon et al.  
 2007/0142914 A1 6/2007 Jones et al.  
 2008/0243258 A1 10/2008 Sancheti  
 2010/0016987 A1 1/2010 Scrafton et al.  
 2011/0029093 A1 2/2011 Bojarski et al.  
 2014/0257507 A1 9/2014 Wang et al.  
 2014/0277548 A1 9/2014 Cohen et al.  
 2015/0032218 A1 1/2015 Landon  
 2015/0093283 A1 4/2015 Miller et al.  
 2015/0257900 A1 9/2015 Dees, Jr.  
 2015/0258735 A1 9/2015 O'Neill et al.  
 2017/0014235 A1 1/2017 Jones et al.  
 2017/0027700 A1 2/2017 Cohen et al.  
 2017/0071744 A1 3/2017 Bali et al.  
 2017/0312084 A1 11/2017 Ferro et al.  
 2017/0333209 A1\* 11/2017 Tsukayama ..... A61F 2/30734  
 2018/0028325 A1 2/2018 Bojarski et al.  
 2018/0049880 A1 2/2018 Sun et al.

OTHER PUBLICATIONS

Reference V, Conformis, Comformis Launches Next Generation of Only Patient-Specific Total Knee Replacement Implant System Available on Market, published Oct. 3, 2012 (6 pages).  
 Reference X, Smith & Nephew, Journey II TKA Total Knee System, Nov. 2013 (68 pages).  
 Reference W, Smith & Nephew, Legion Total Knee System, Apr. 2015 (8 pgs).  
 Office Action dated Oct. 28, 2020, issued in corresponding U.S. Appl. No. 16/046,554.

\* cited by examiner

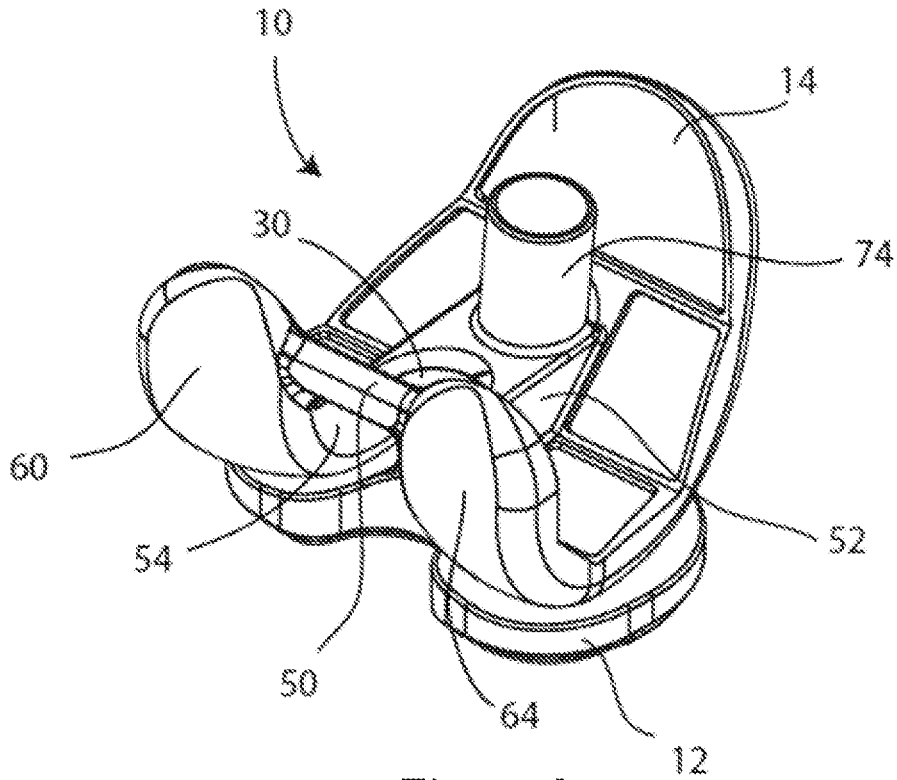

Fig. 1A

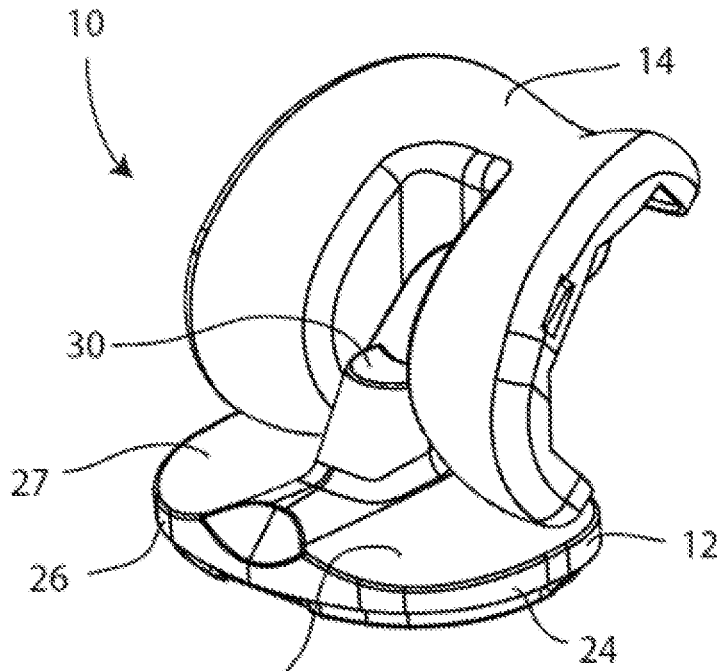

Fig. 1B

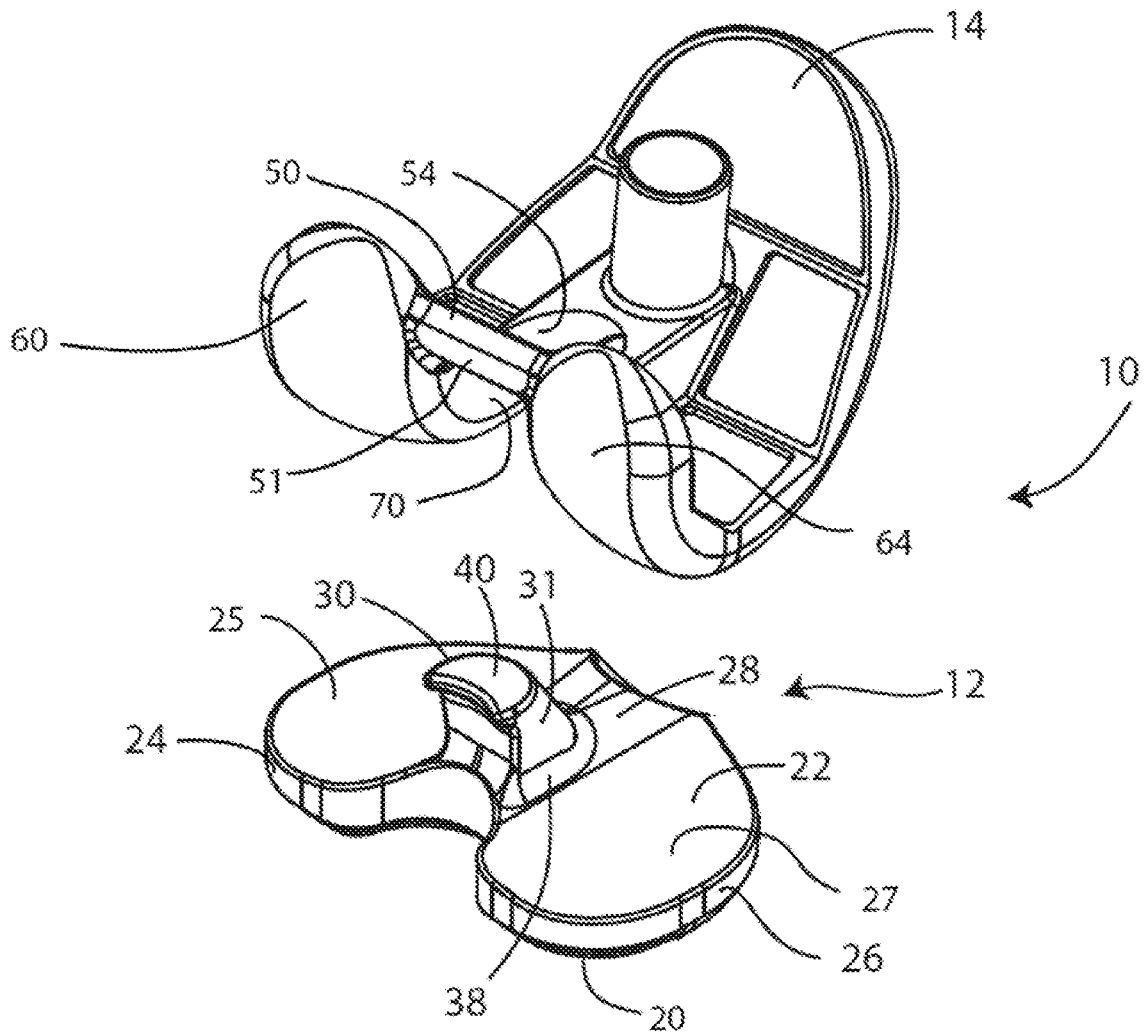

Fig. 2

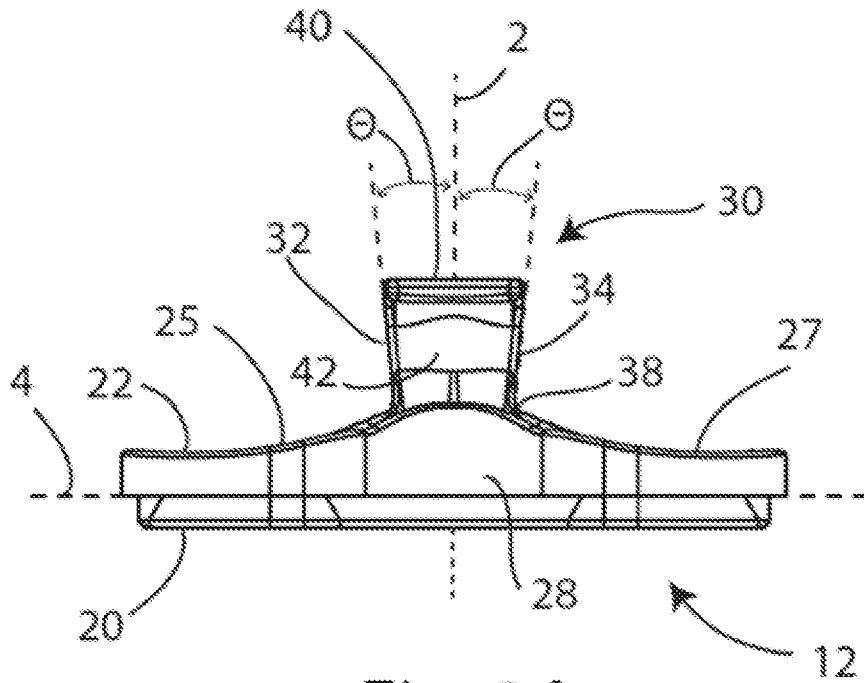

Fig. 3A

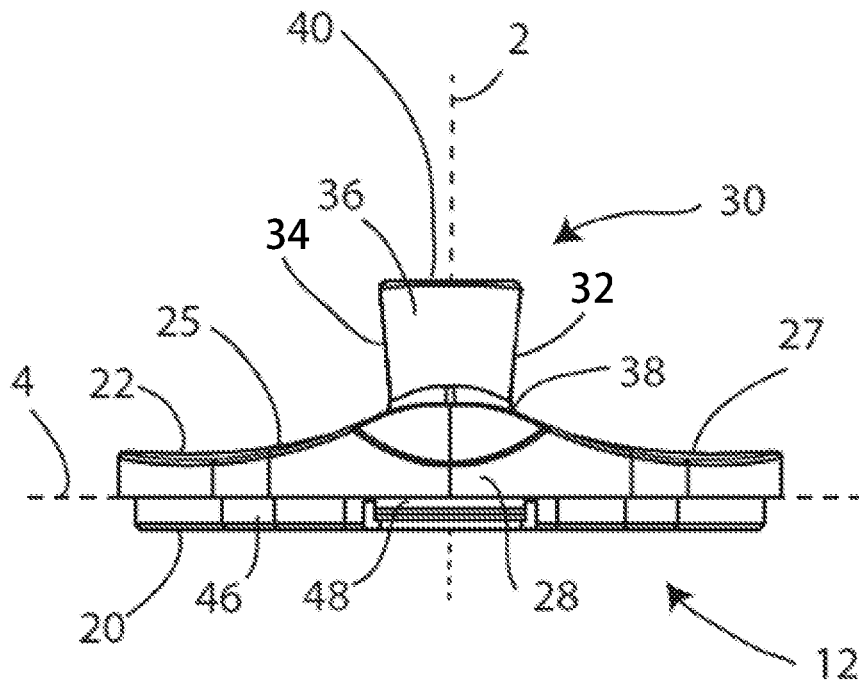

Fig. 3B

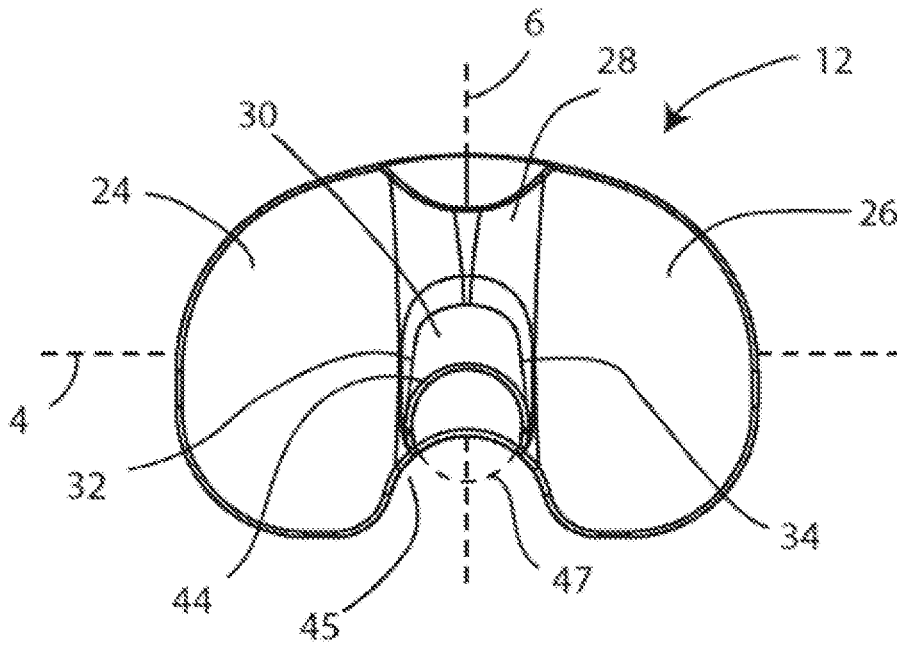

Fig. 3C

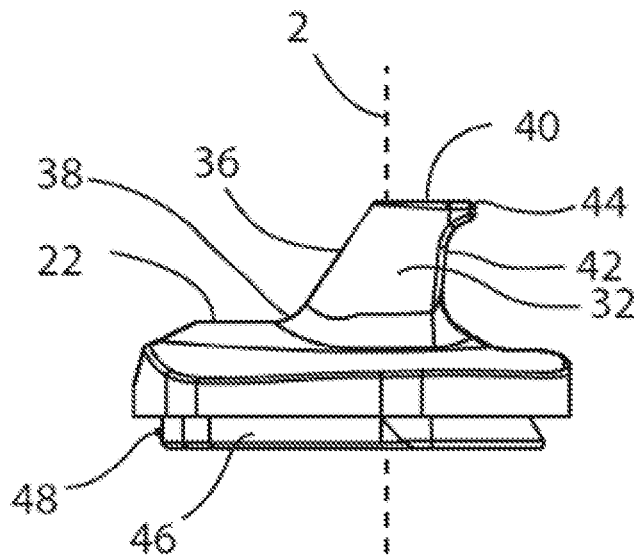

Fig. 3D

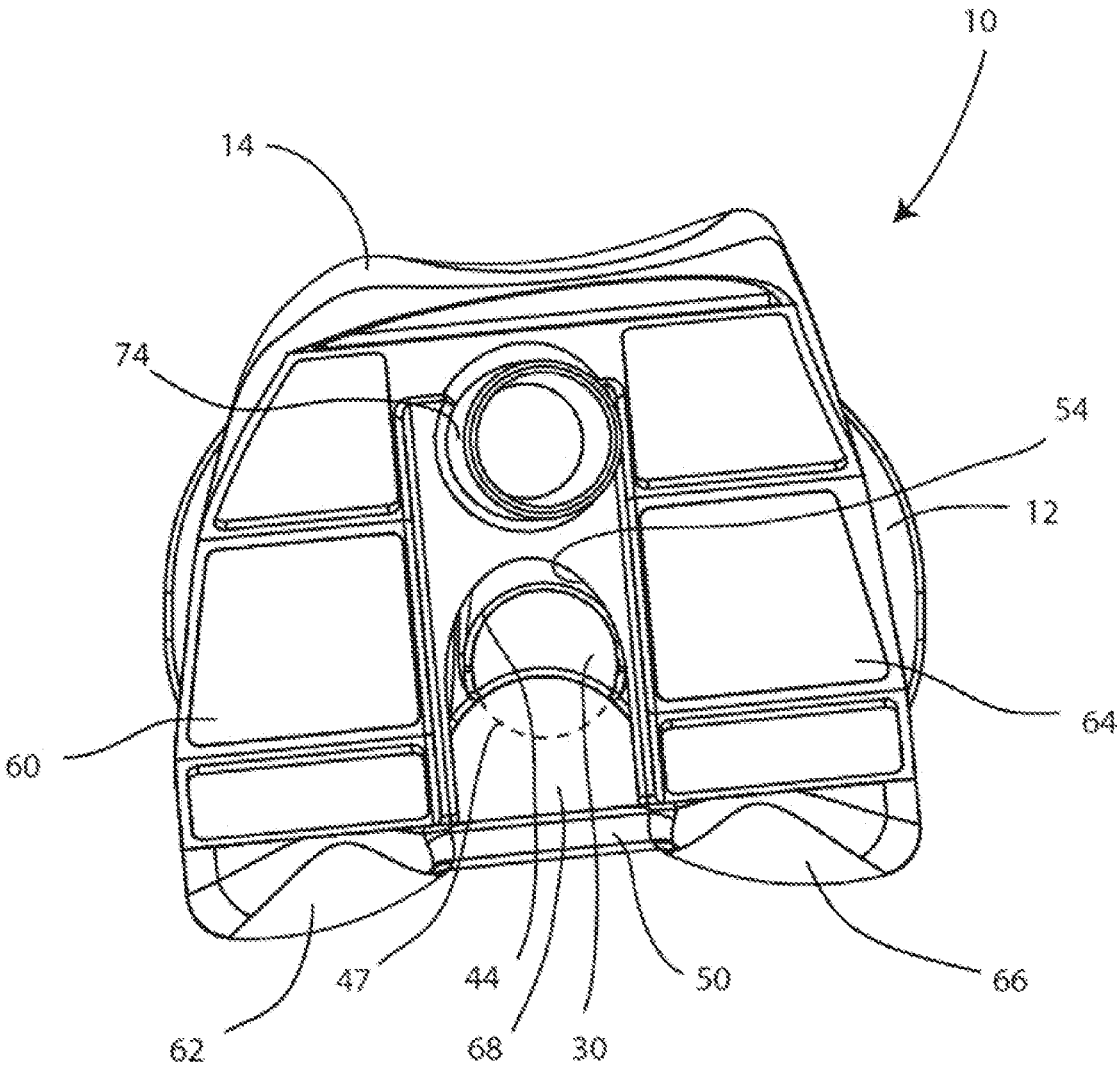

Fig. 4



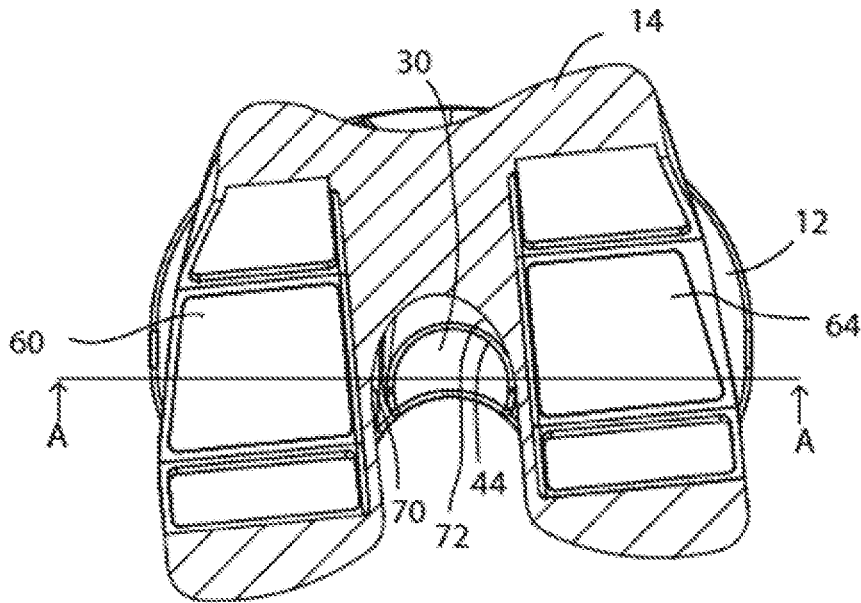

Fig. 5

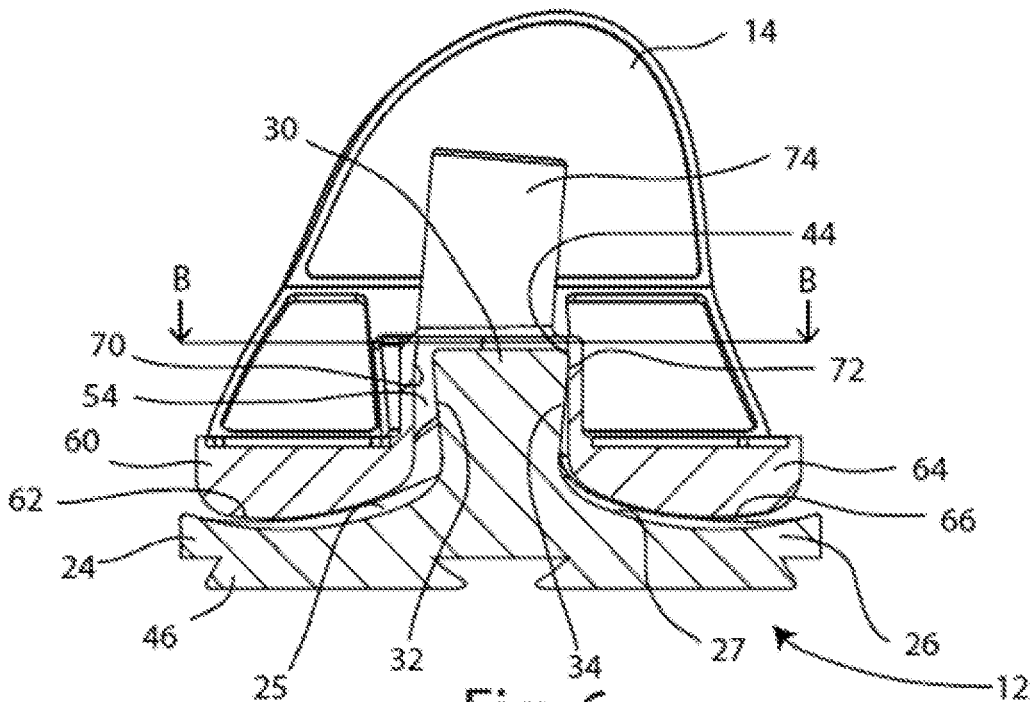

Fig. 6



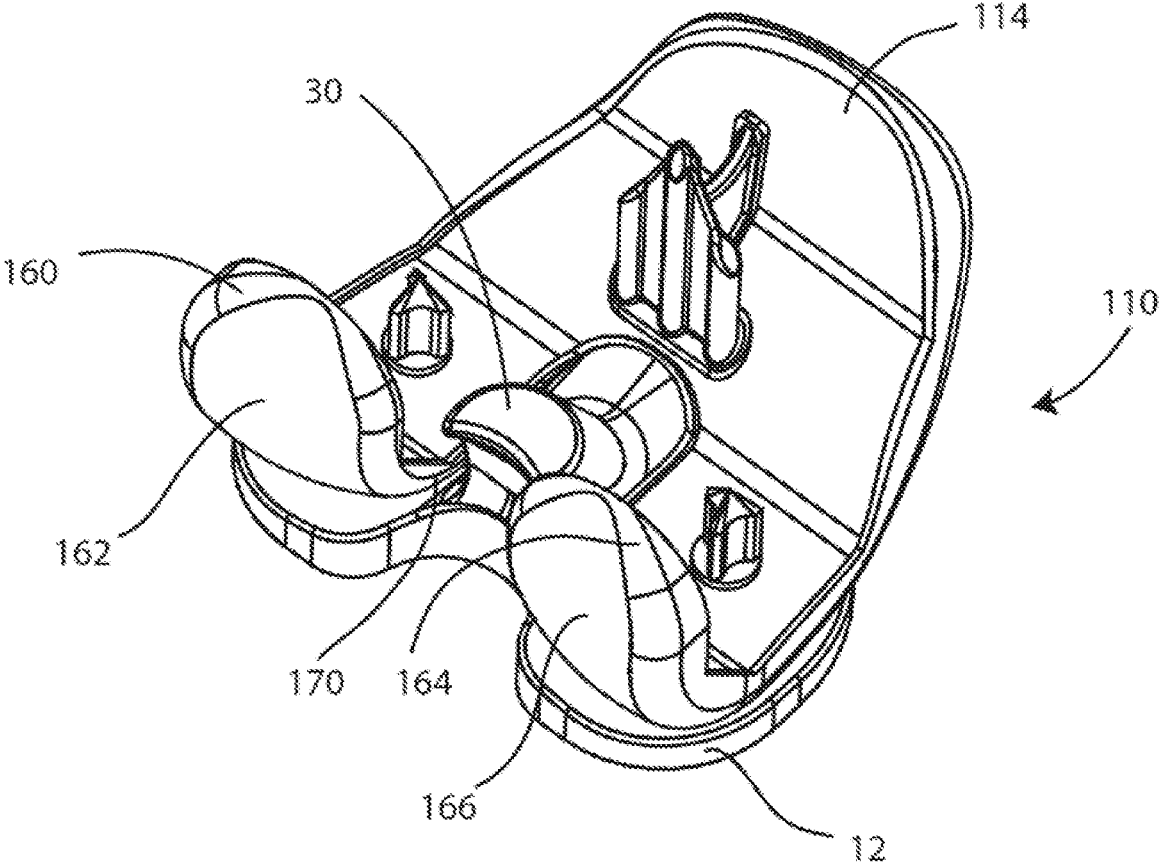

Fig. 9

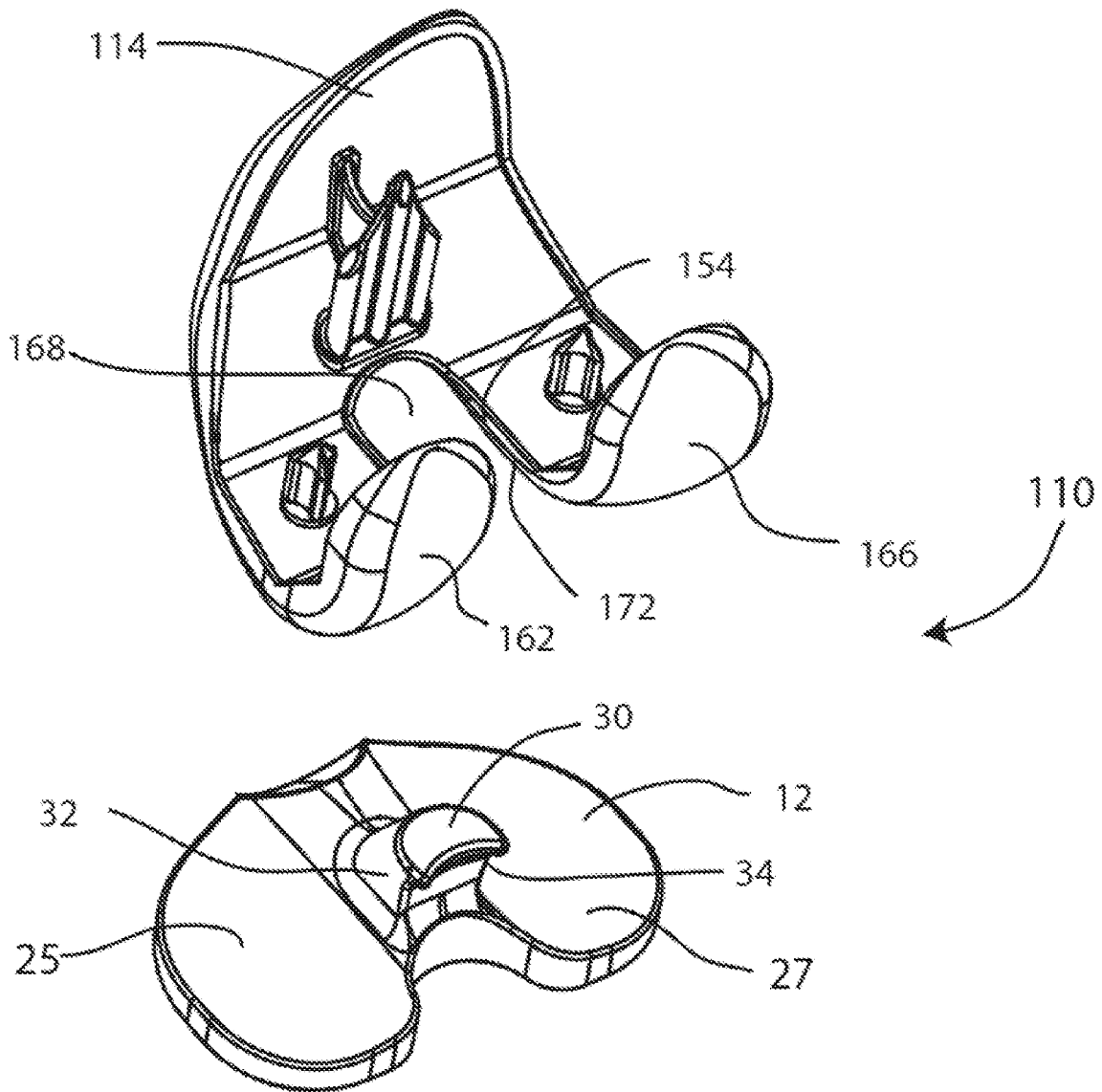
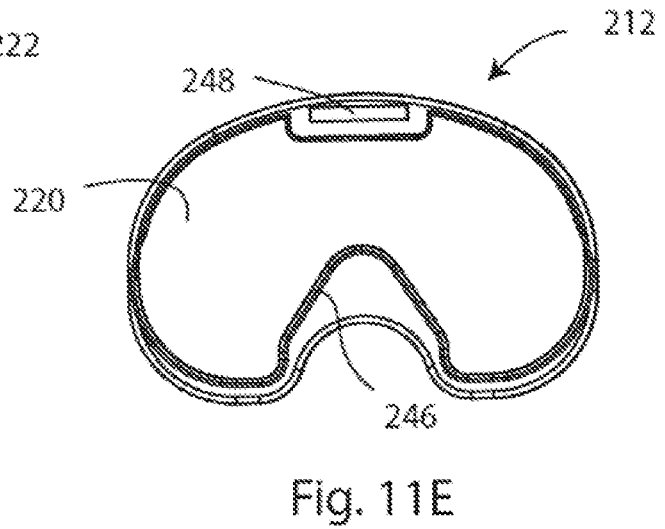
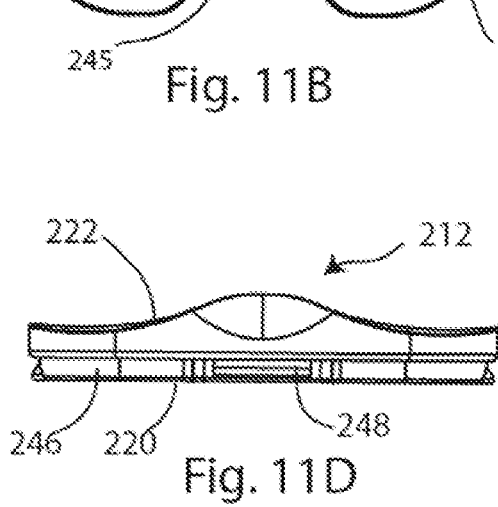
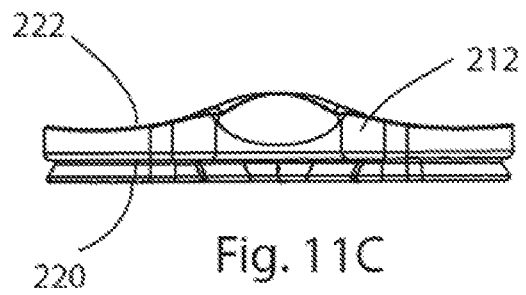
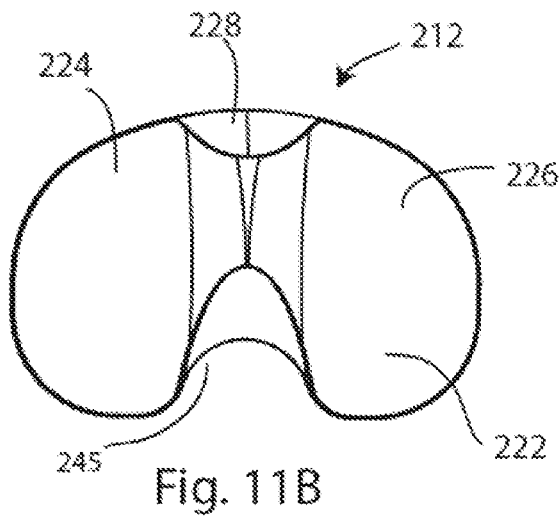
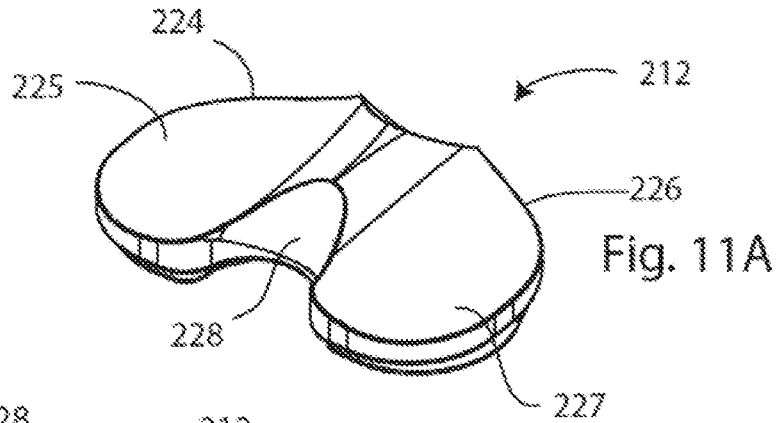

Fig. 10



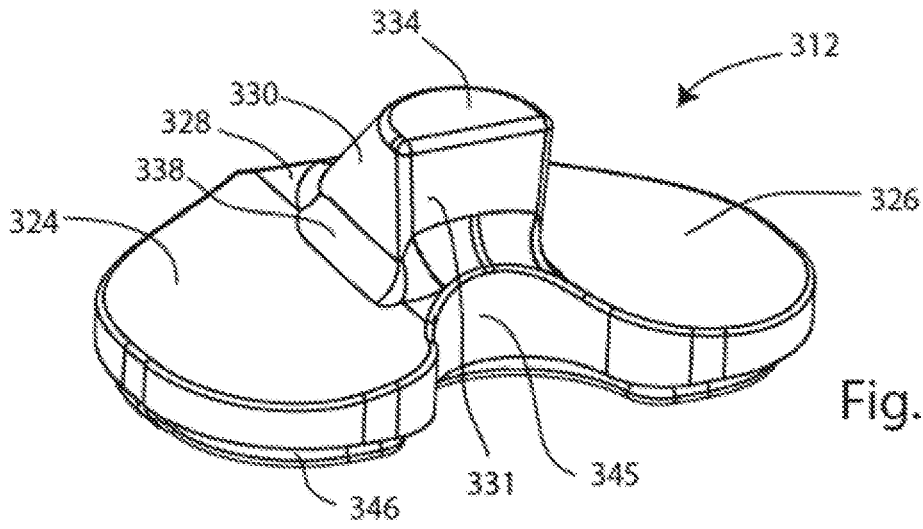

Fig. 12A

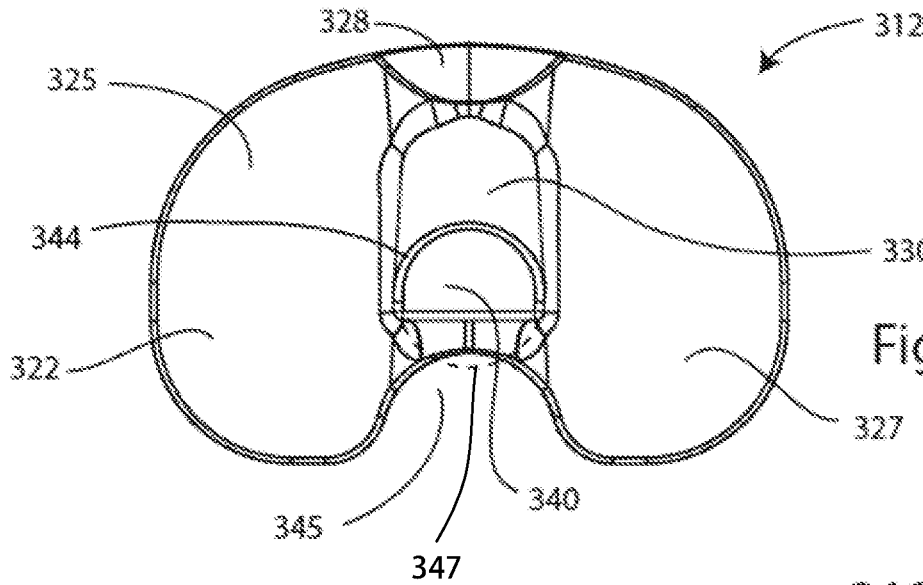

Fig 12B

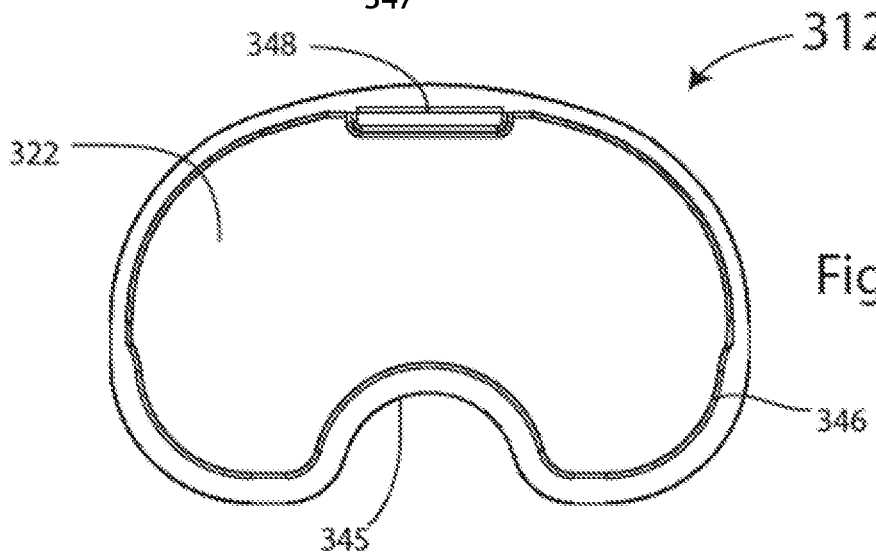

Fig. 12C

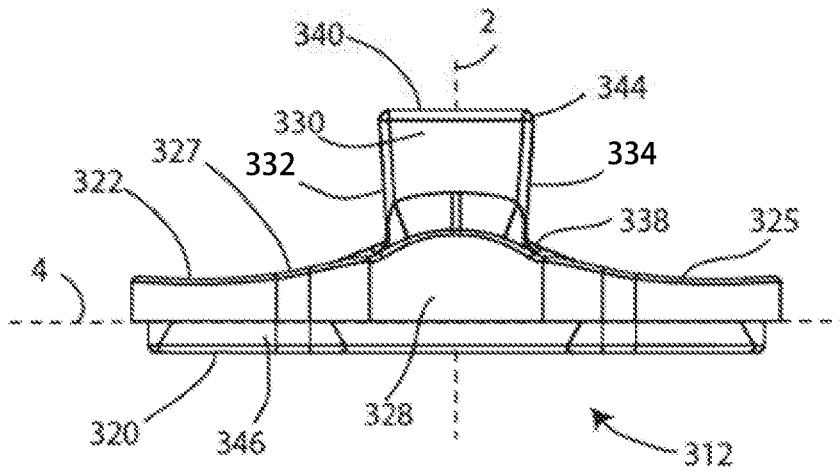

Fig. 12D

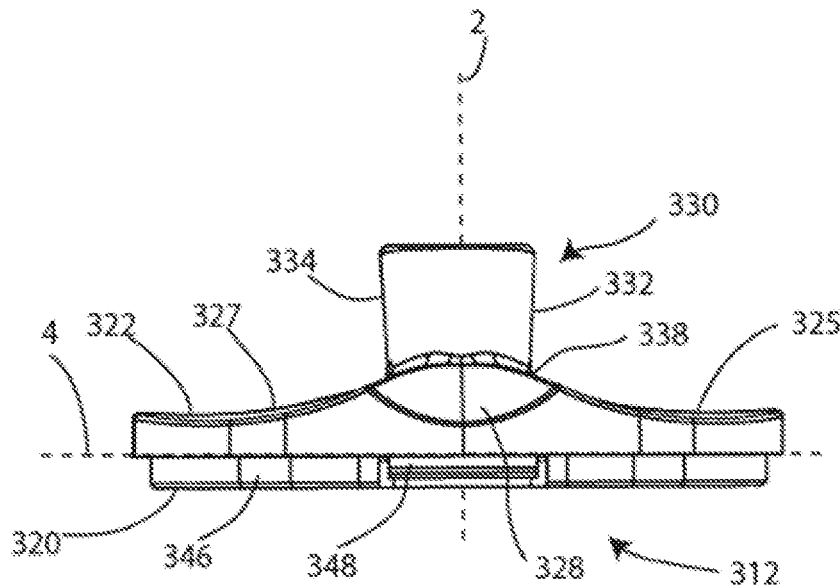

Fig. 12E

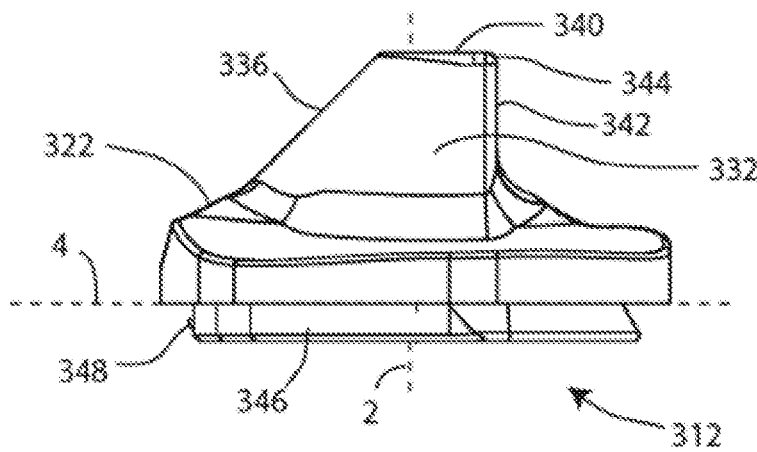

Fig. 12F

	Cruciate Retaining Insert	Posterior Stabilizing Insert	Constrained Condylar Knee Insert
Cruciate Retaining Femoral Component	X	X	X
Posterior Stabilizing Femoral Component	X	X	X

Fig. 13



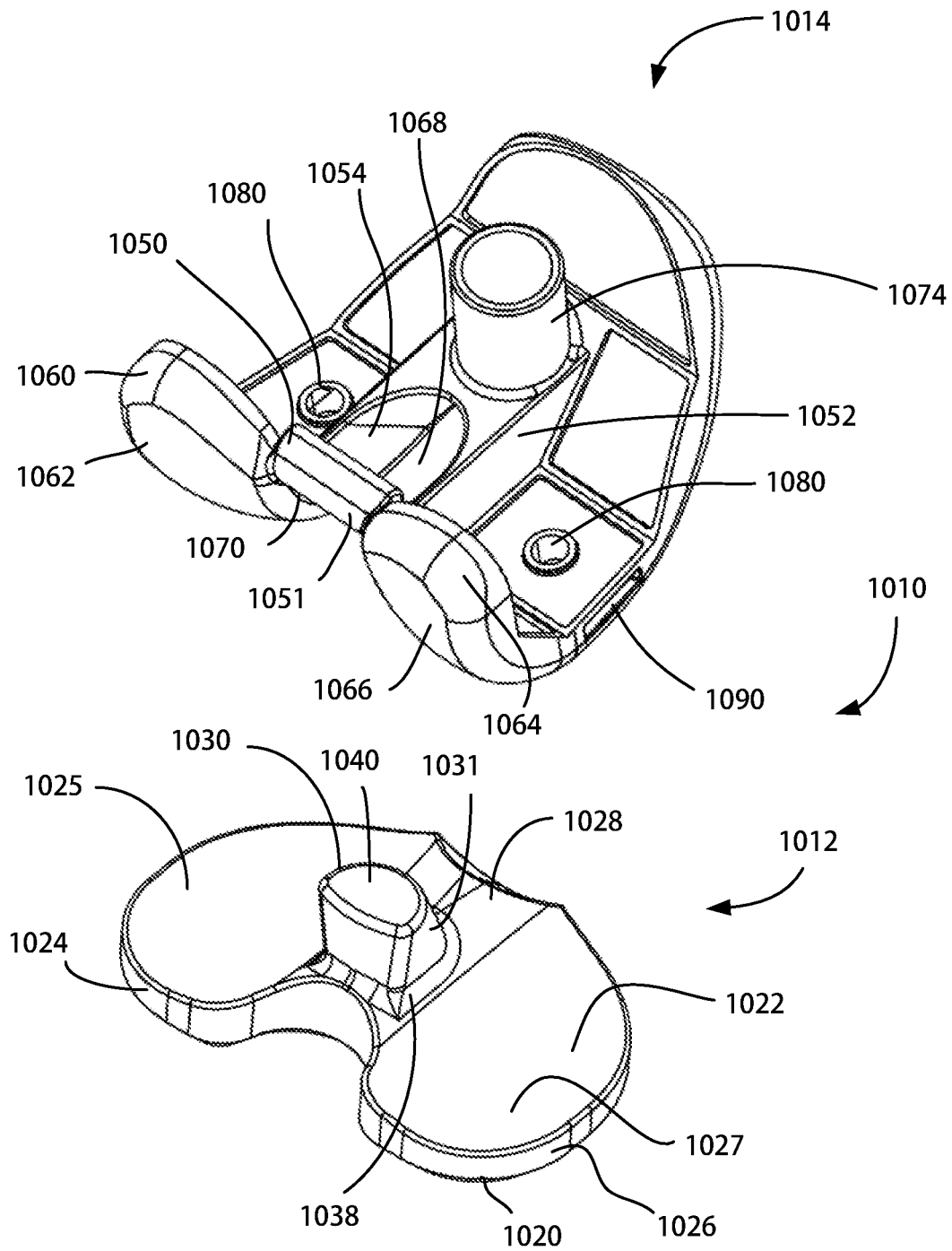

Fig. 14

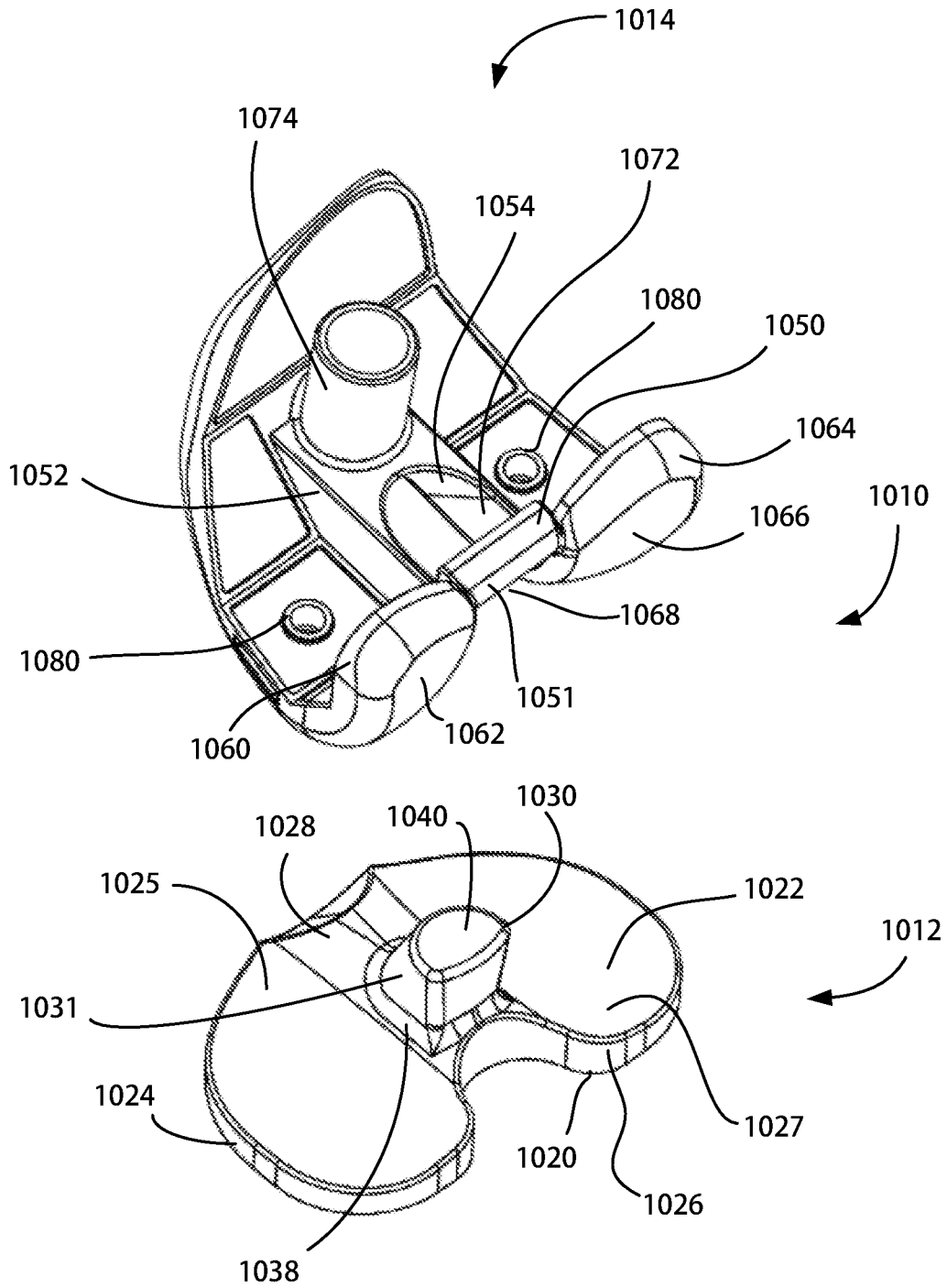

Fig. 15

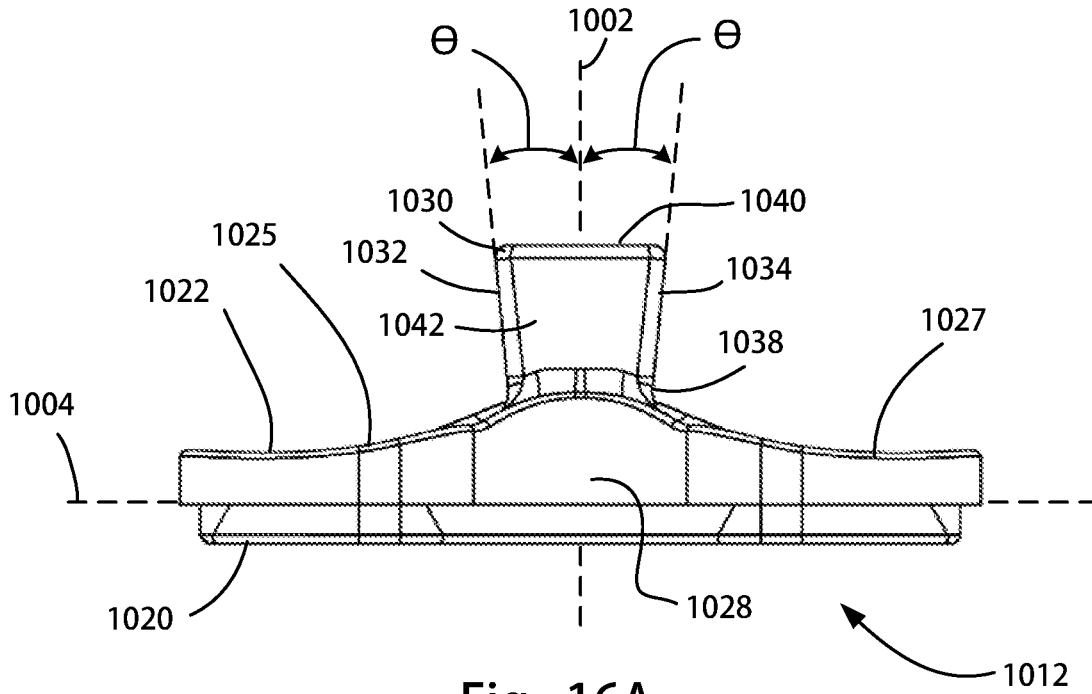

Fig. 16A

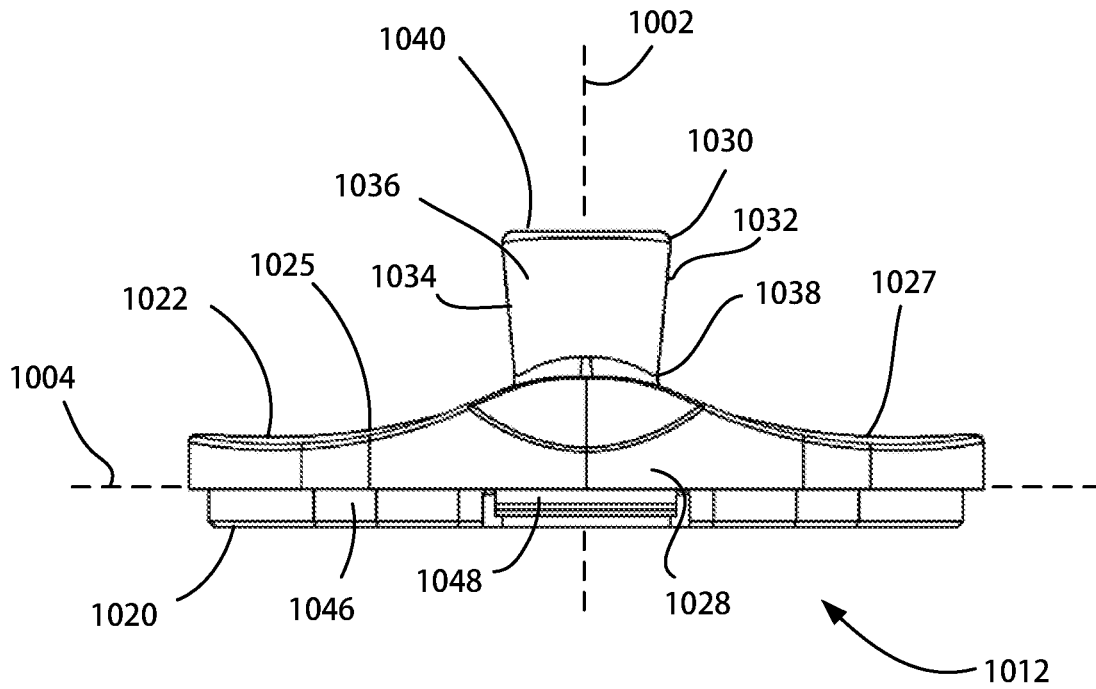

Fig. 16B

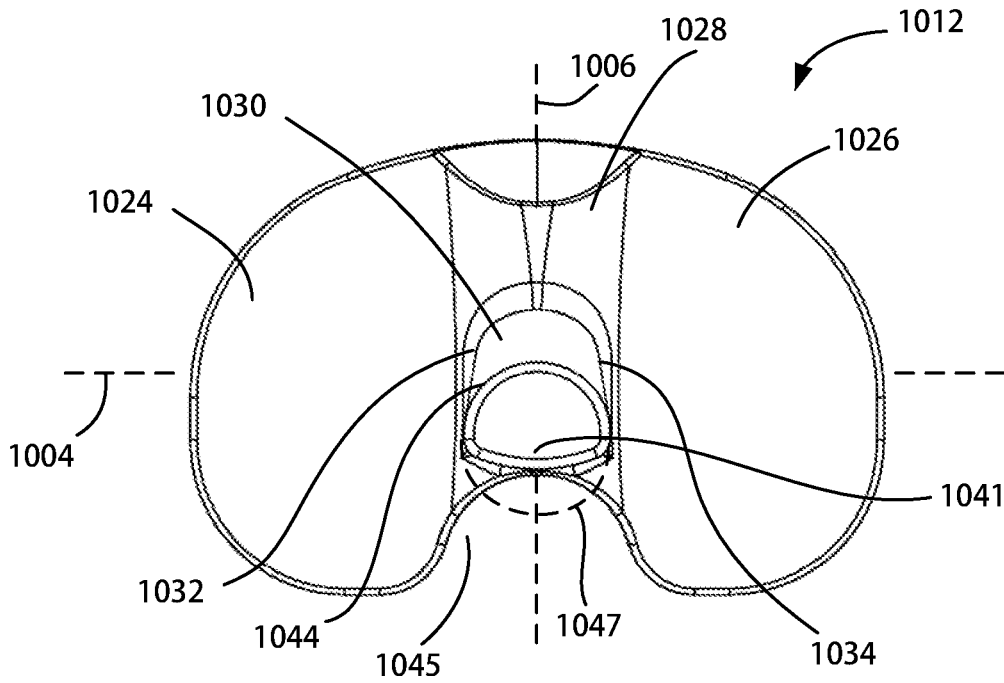

Fig. 16C

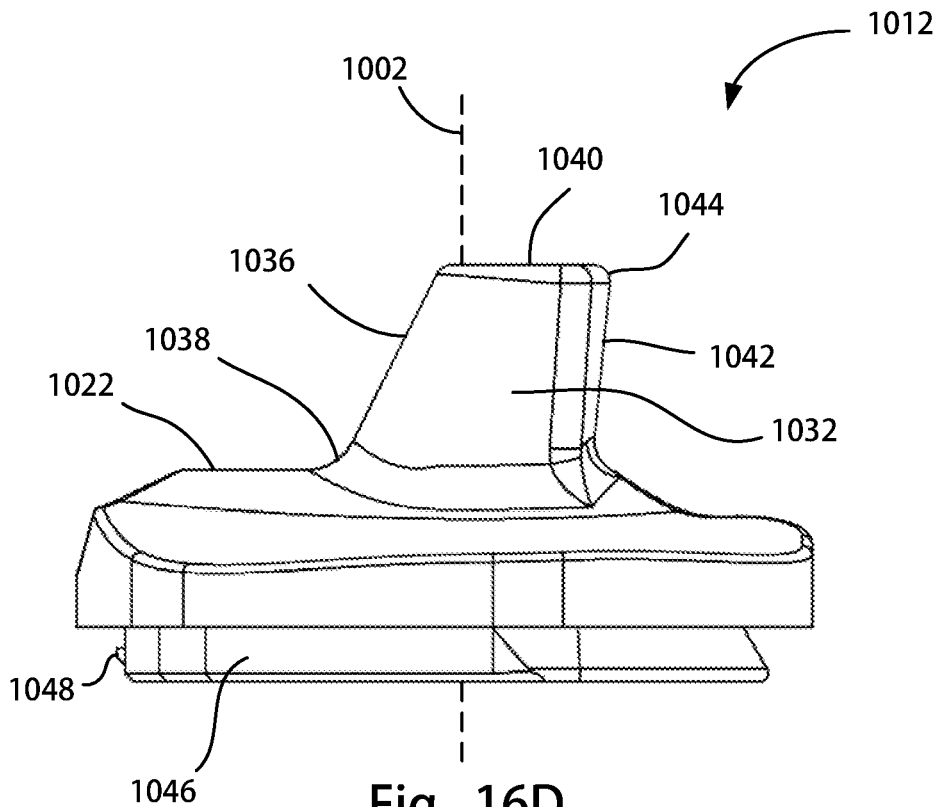

Fig. 16D

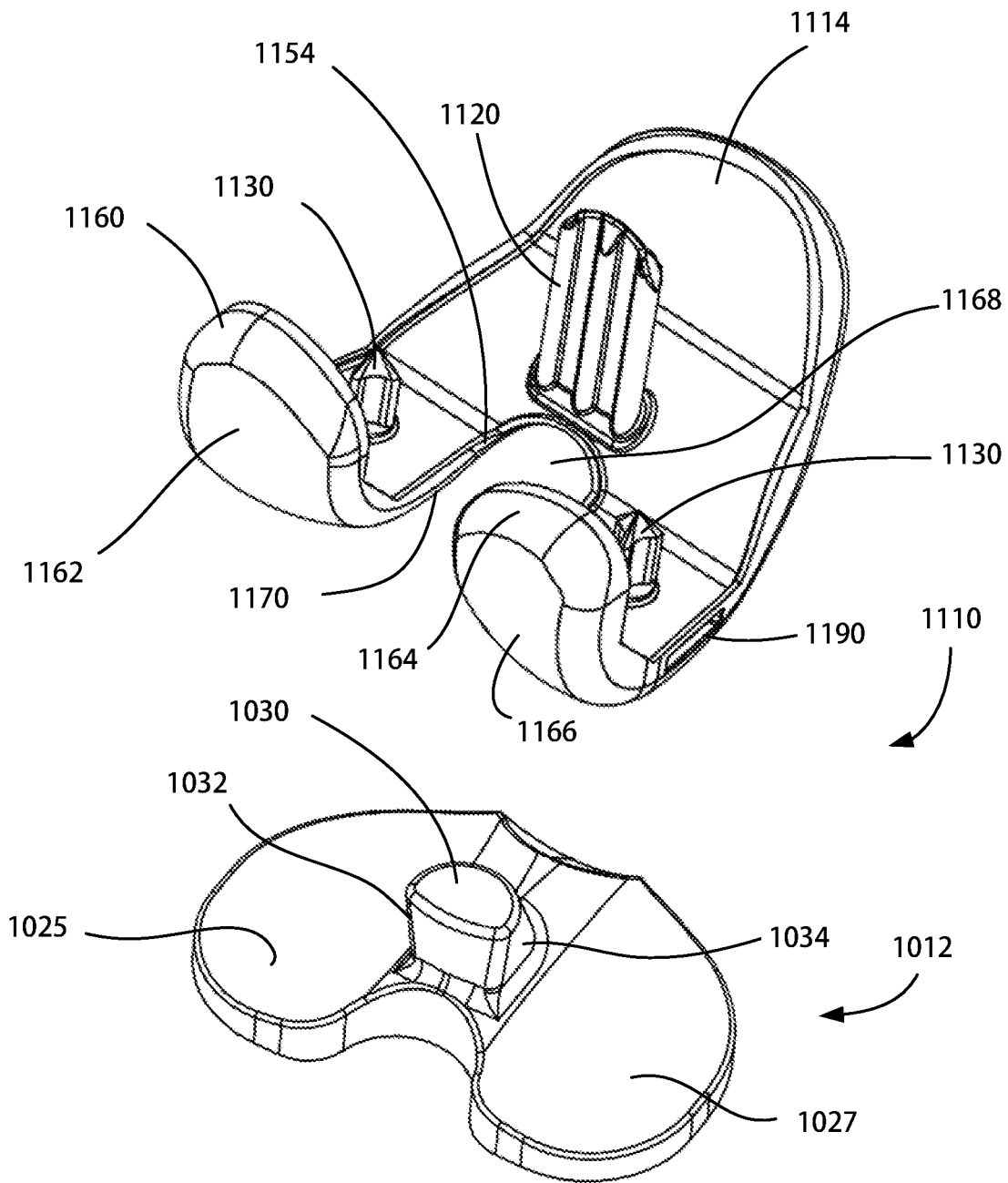

Fig. 17

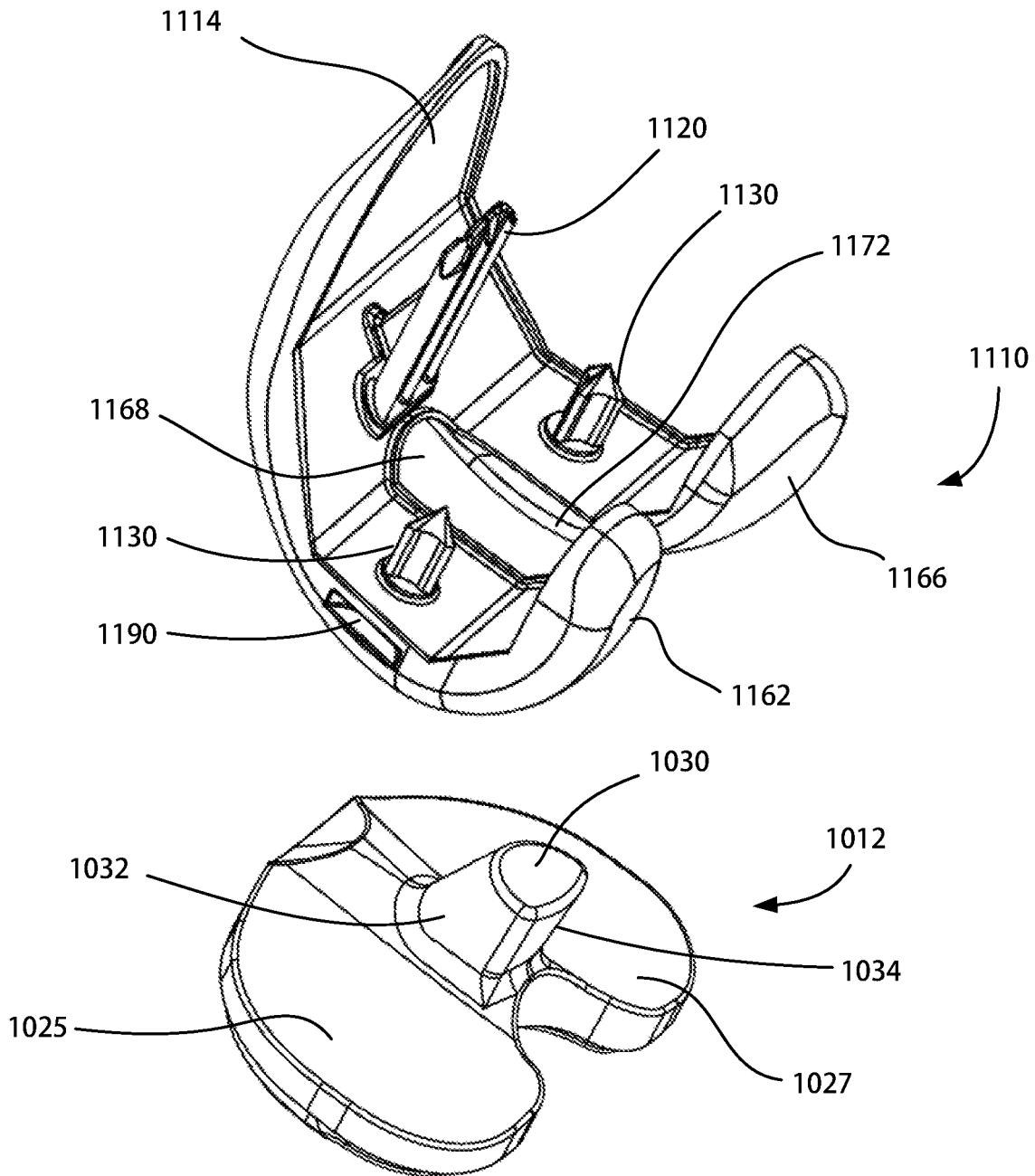

Fig. 18

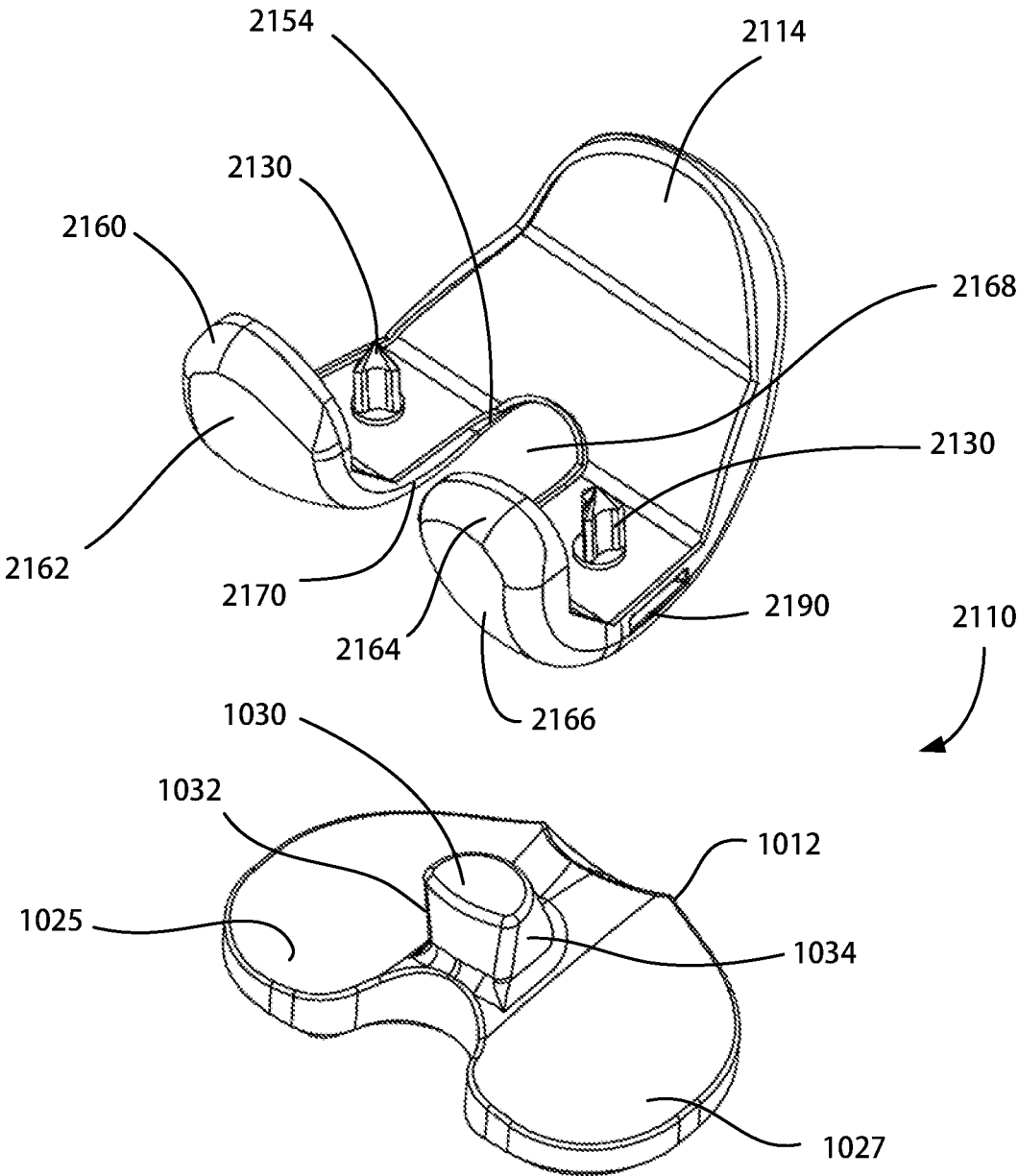

Fig. 19

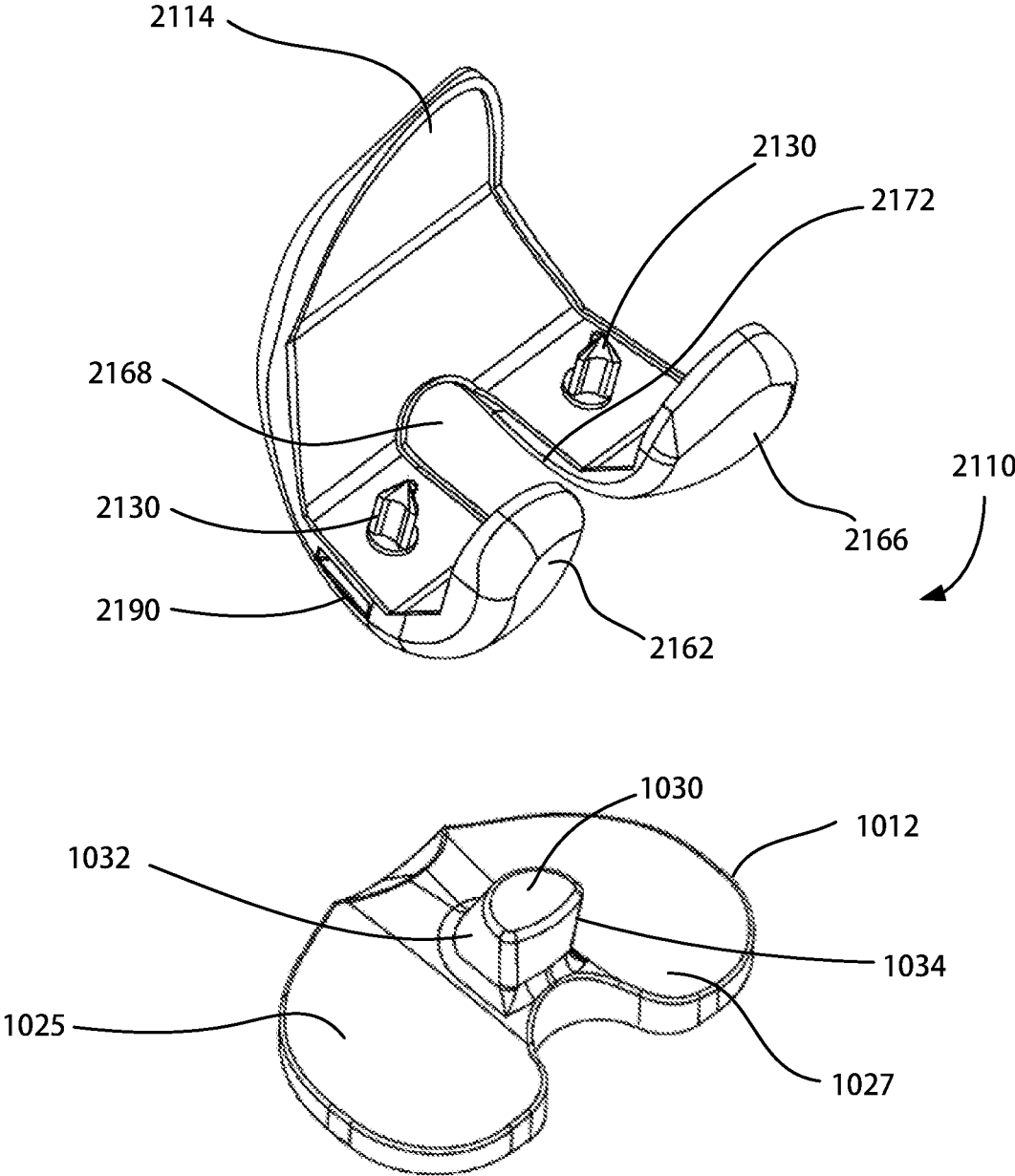

Fig. 20



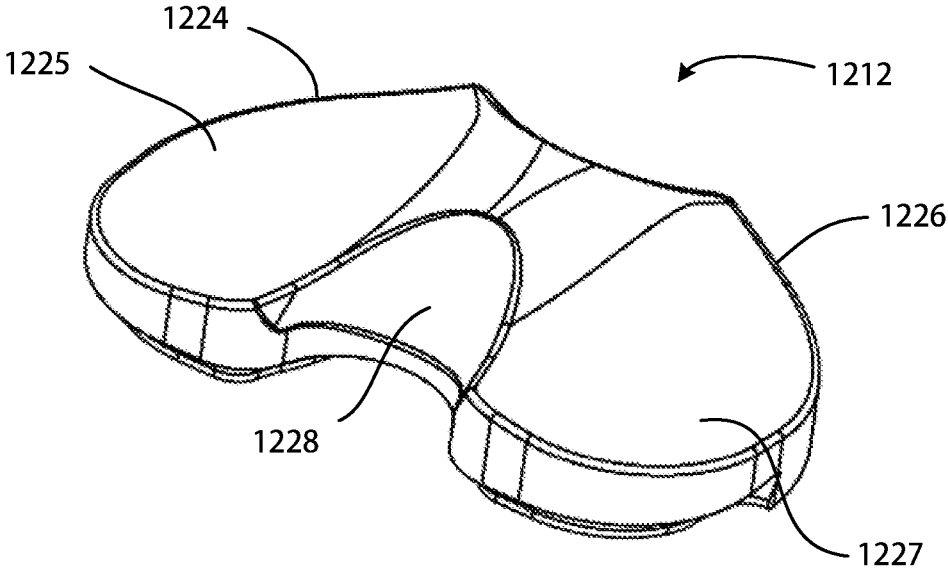

Fig. 21A

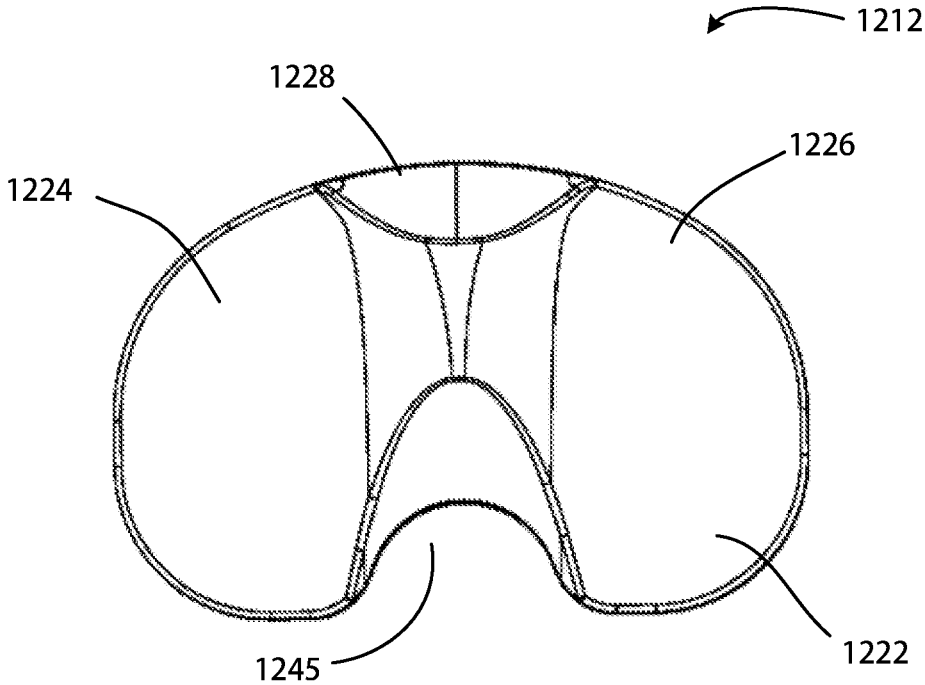

Fig. 21B

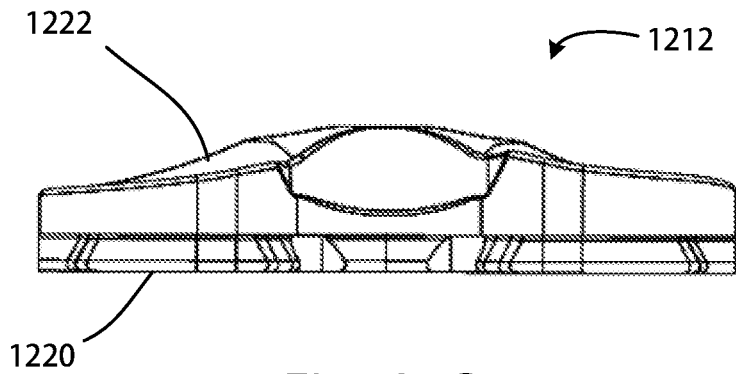

Fig. 21C

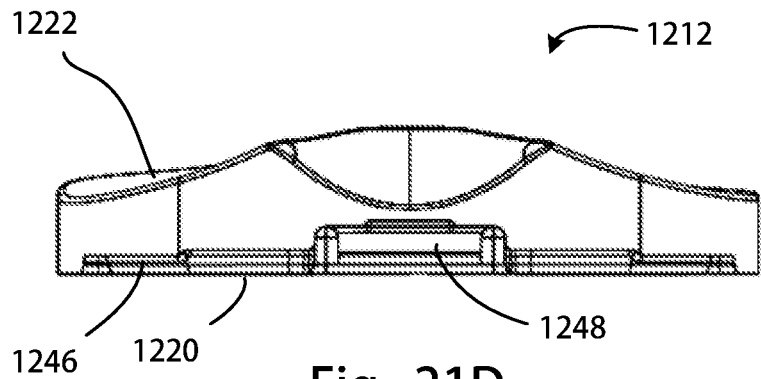

Fig. 21D

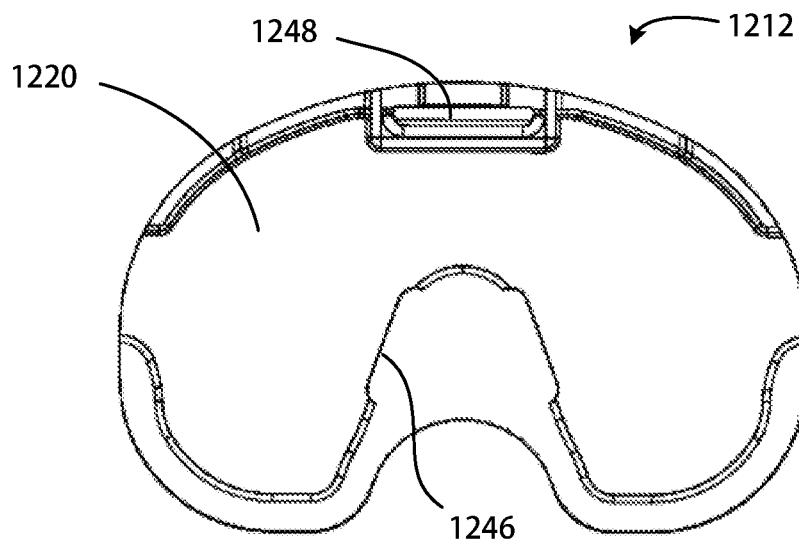

Fig. 21E

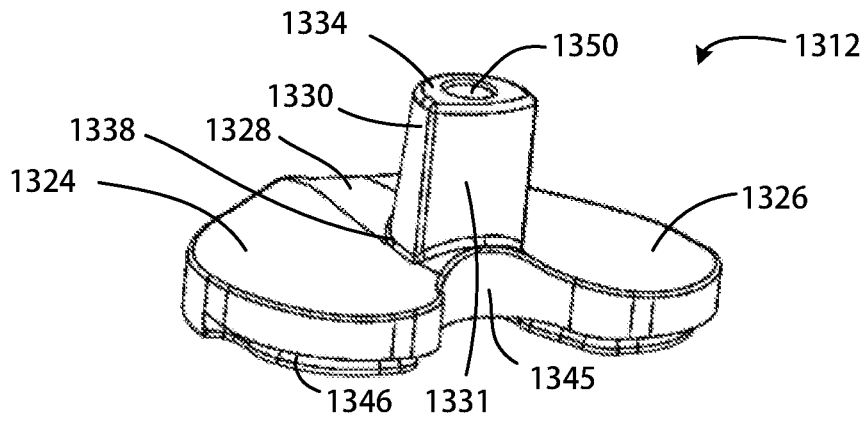

Fig. 22A

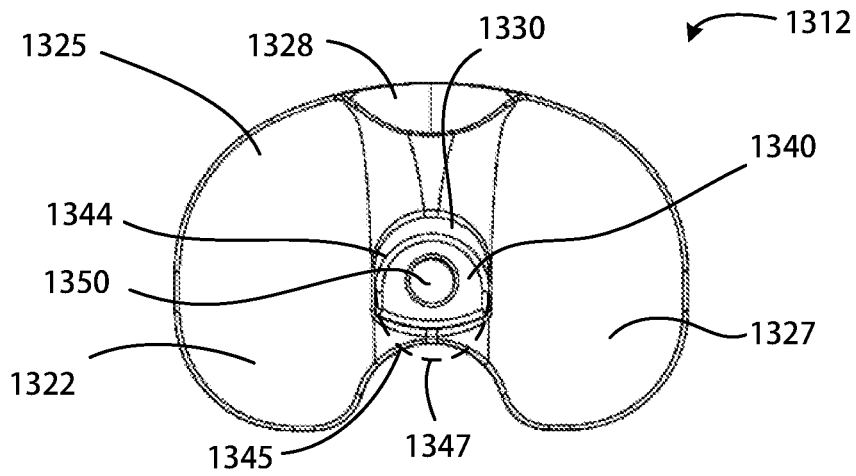

Fig. 22B

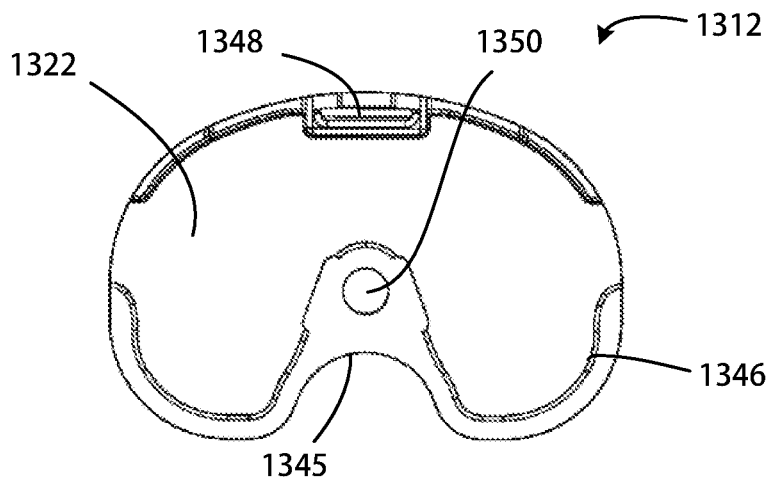

Fig. 22C

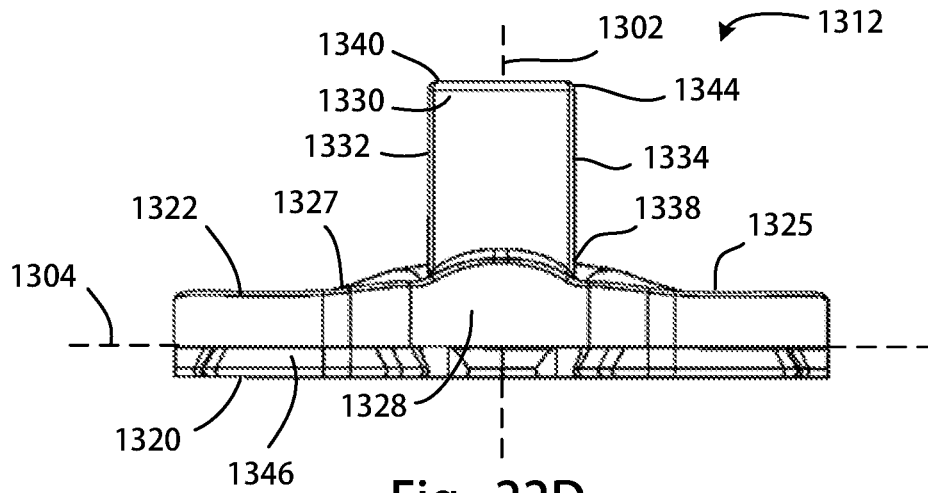

Fig. 22D

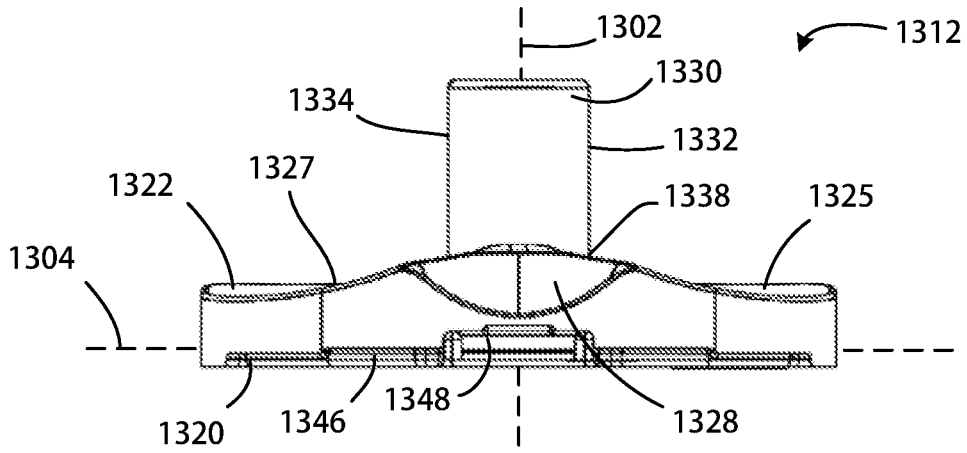

Fig. 22E

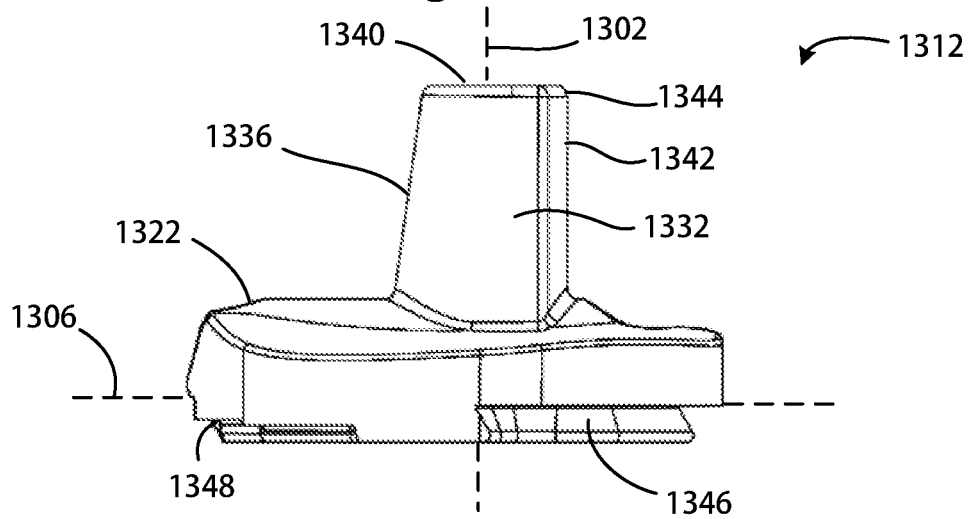

Fig. 22F

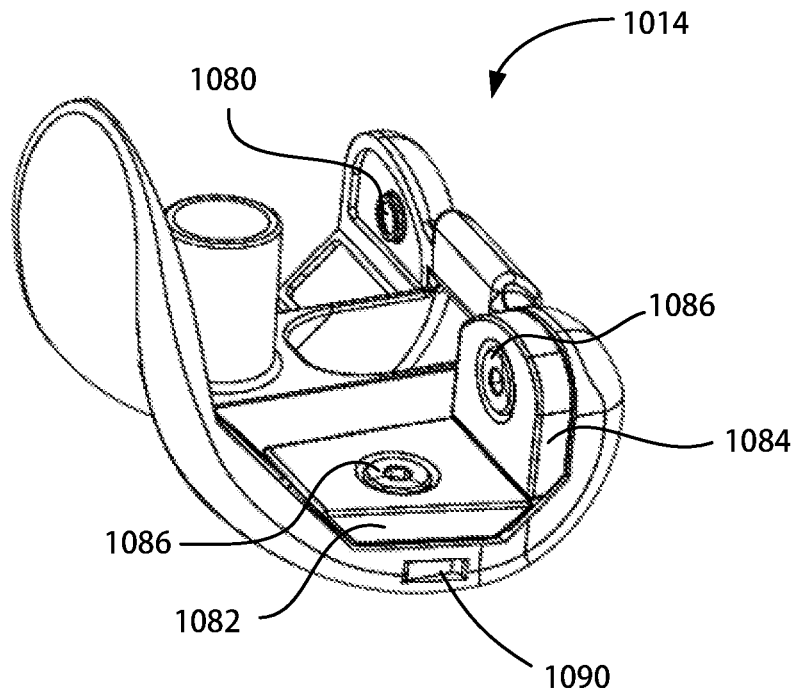

Fig. 23A

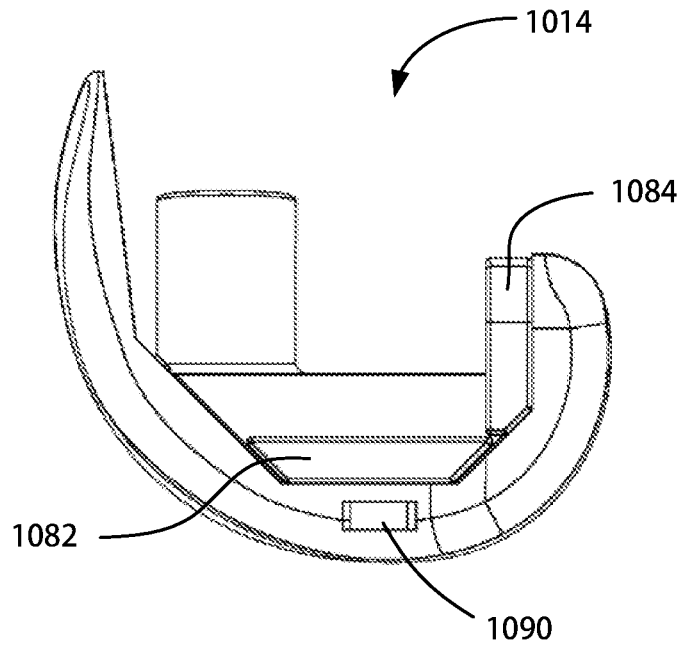

Fig. 23B

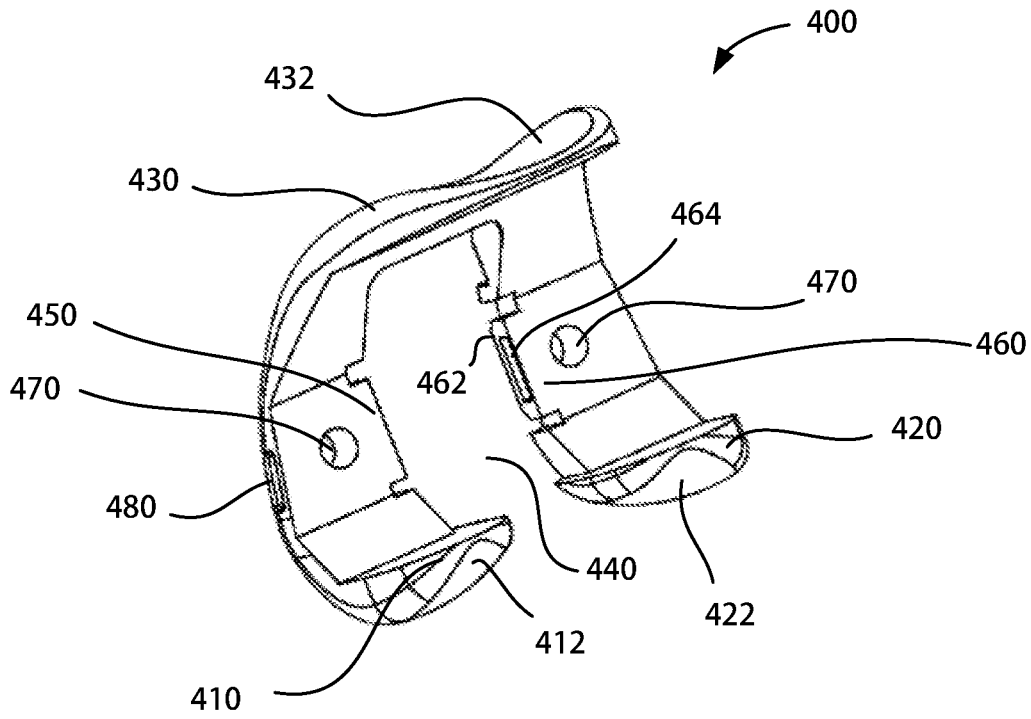

Fig. 24A

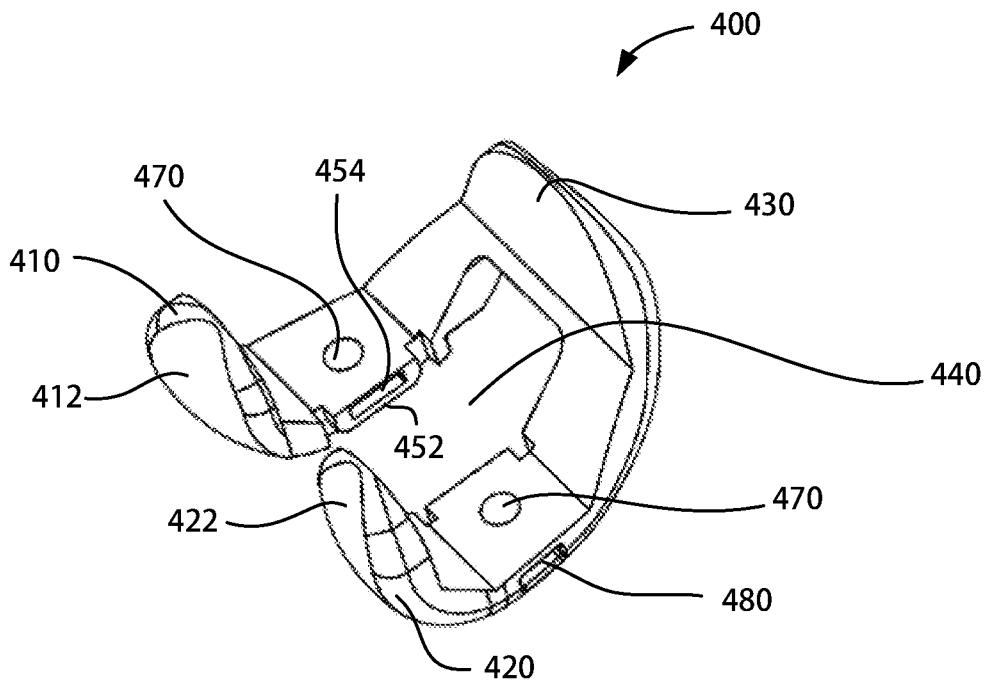

Fig. 24B

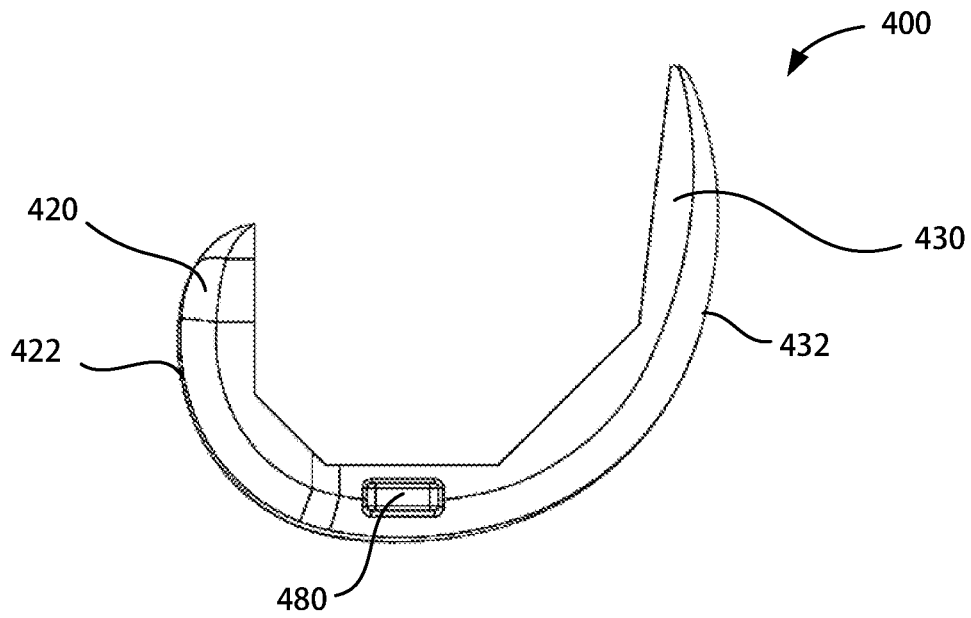

Fig. 24C

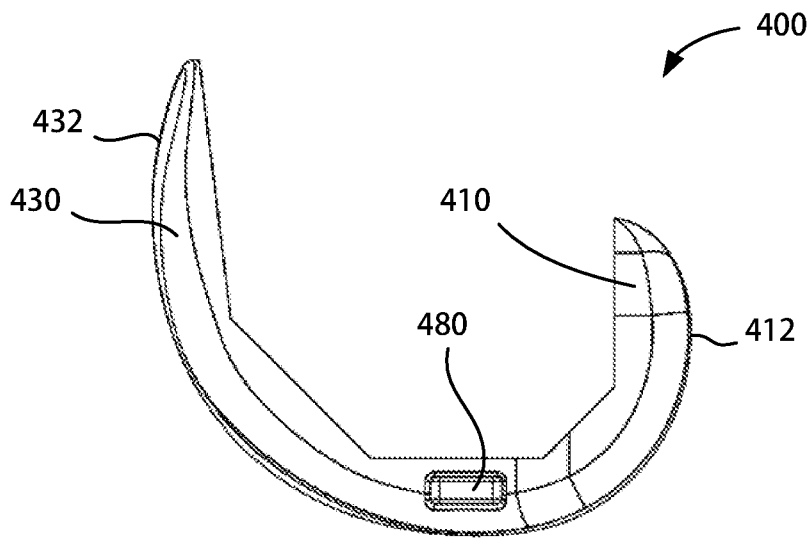

Fig. 24D

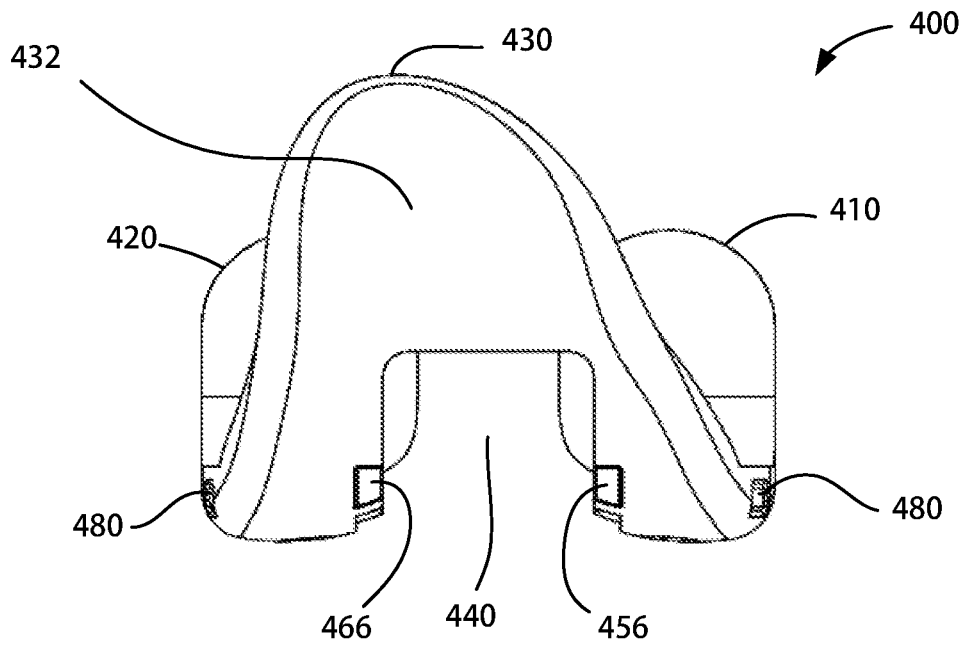

Fig. 24E

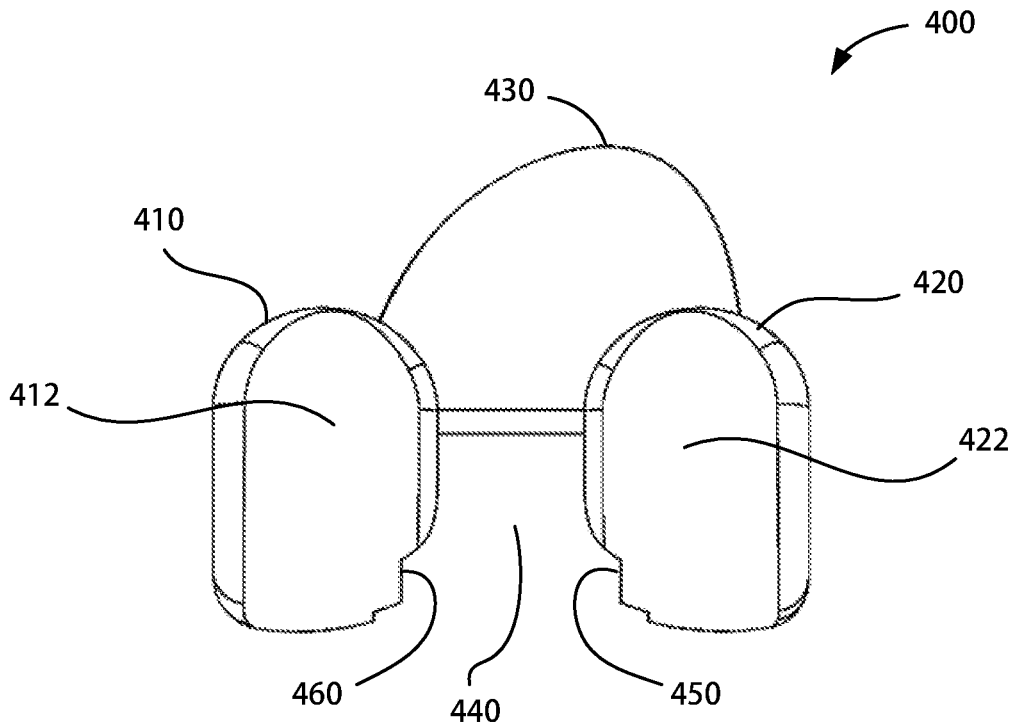

Fig. 24F



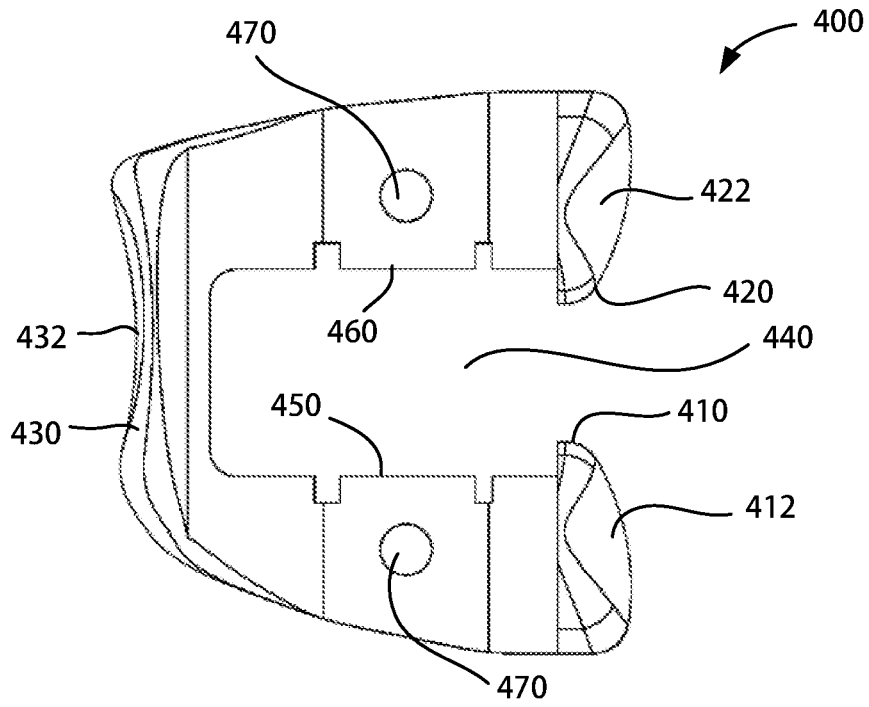

Fig. 24G

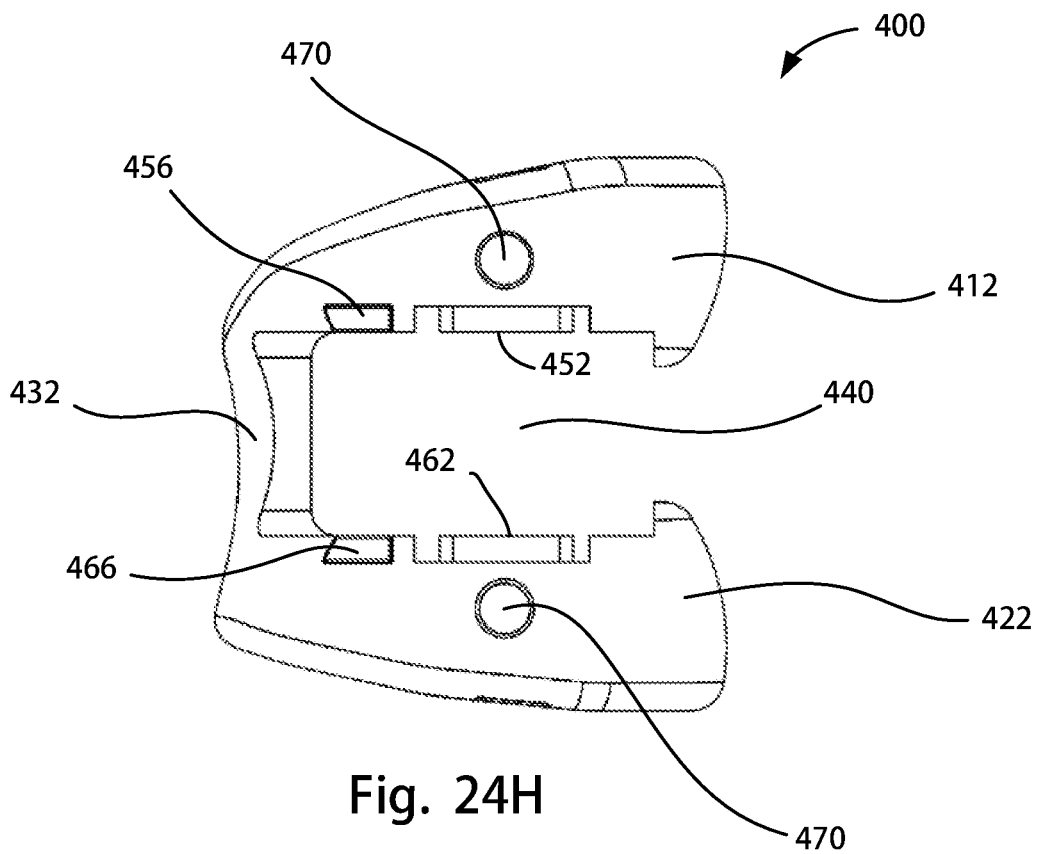

Fig. 24H

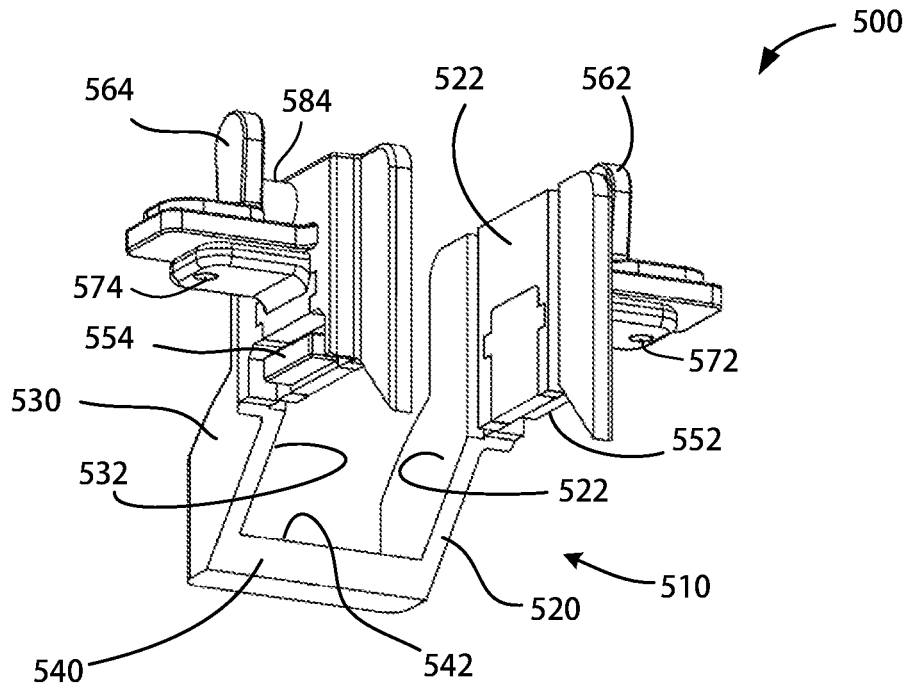

Fig. 25A

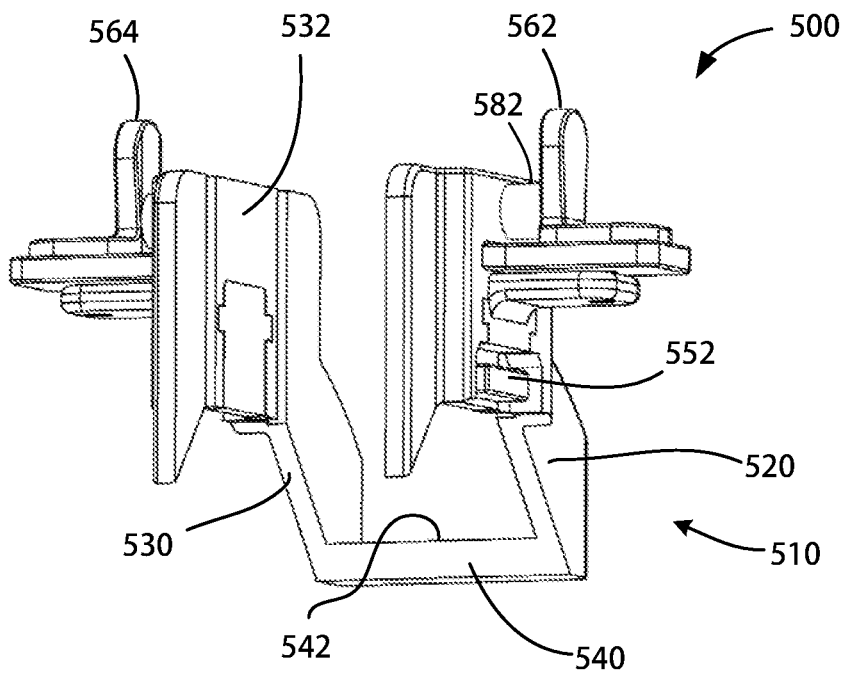

Fig. 25B

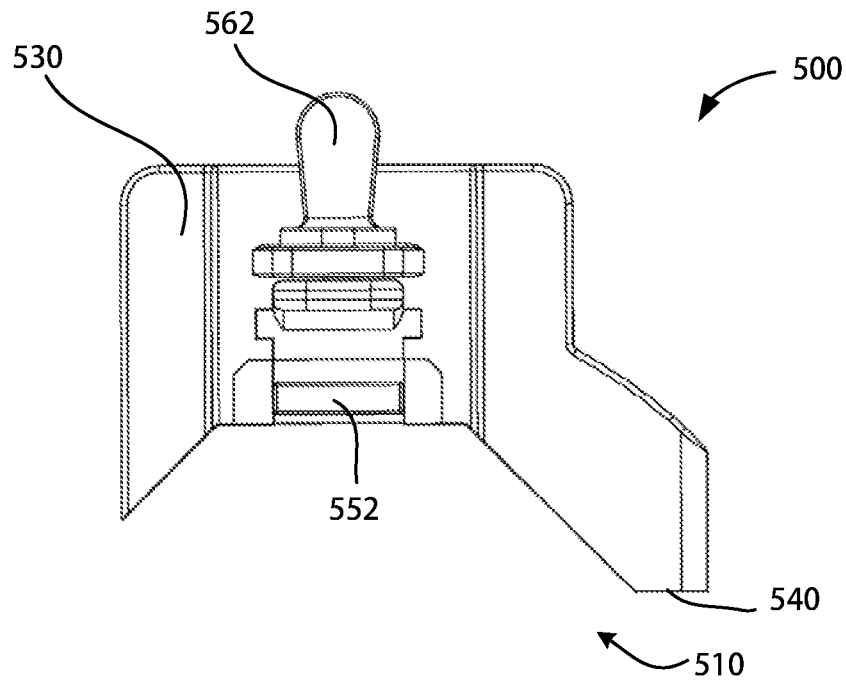

Fig. 25C

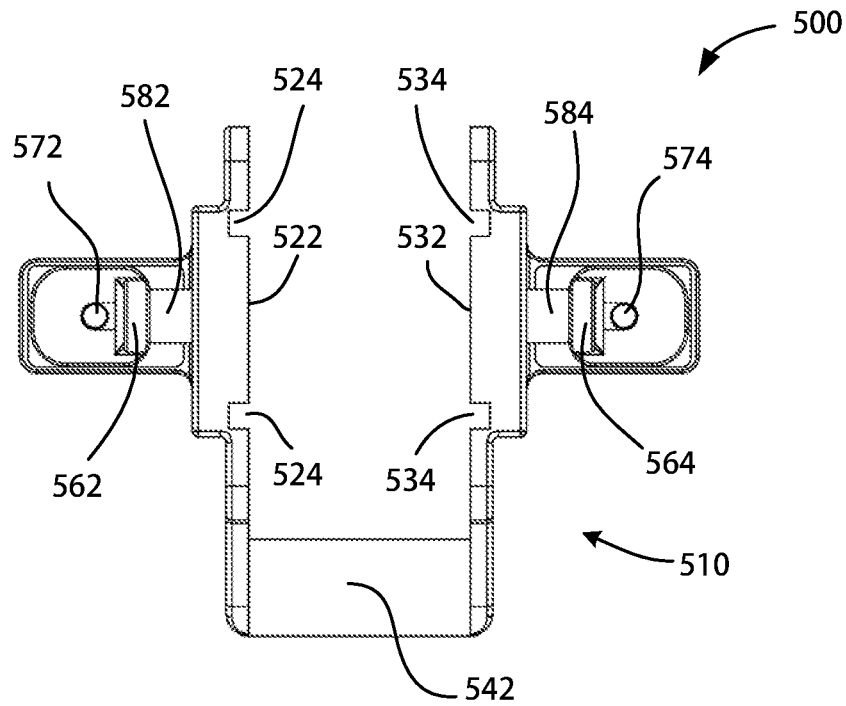

Fig. 25D

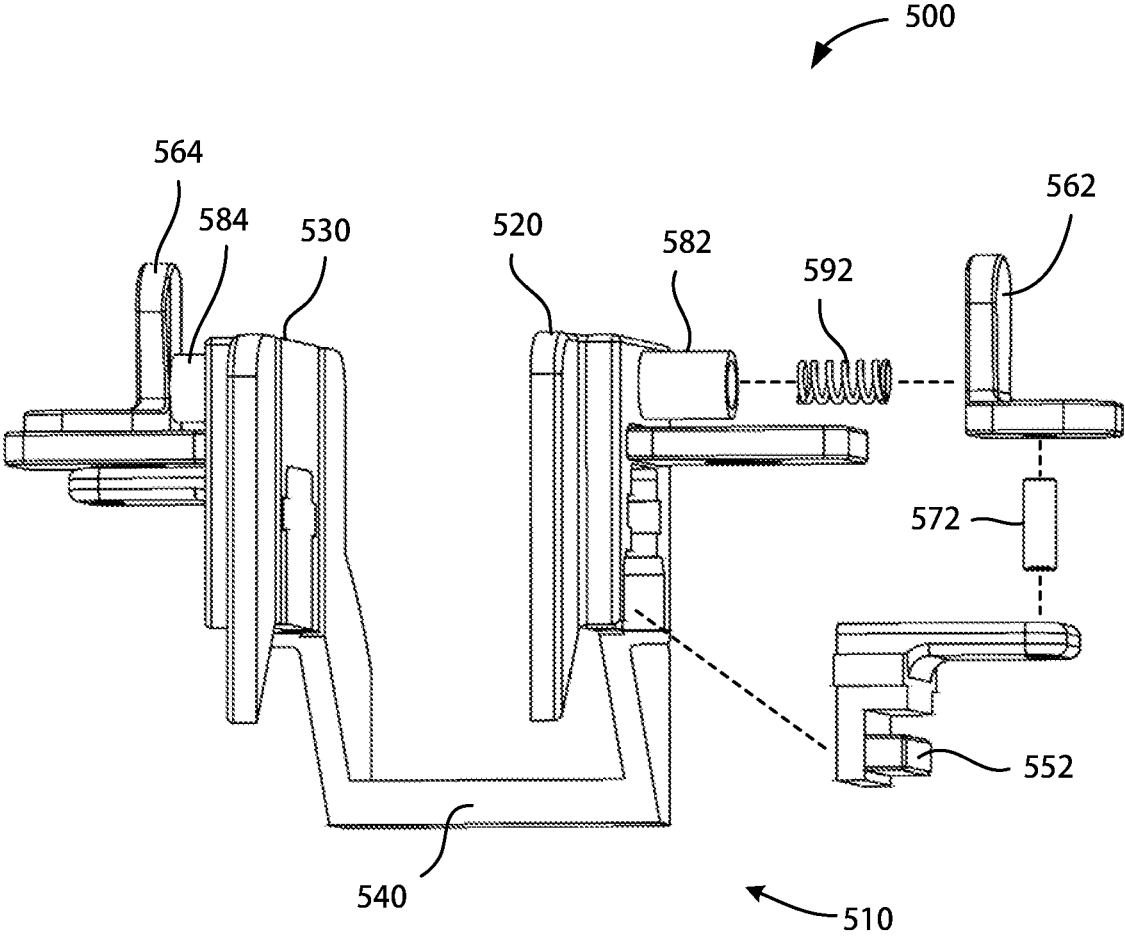

Fig. 26

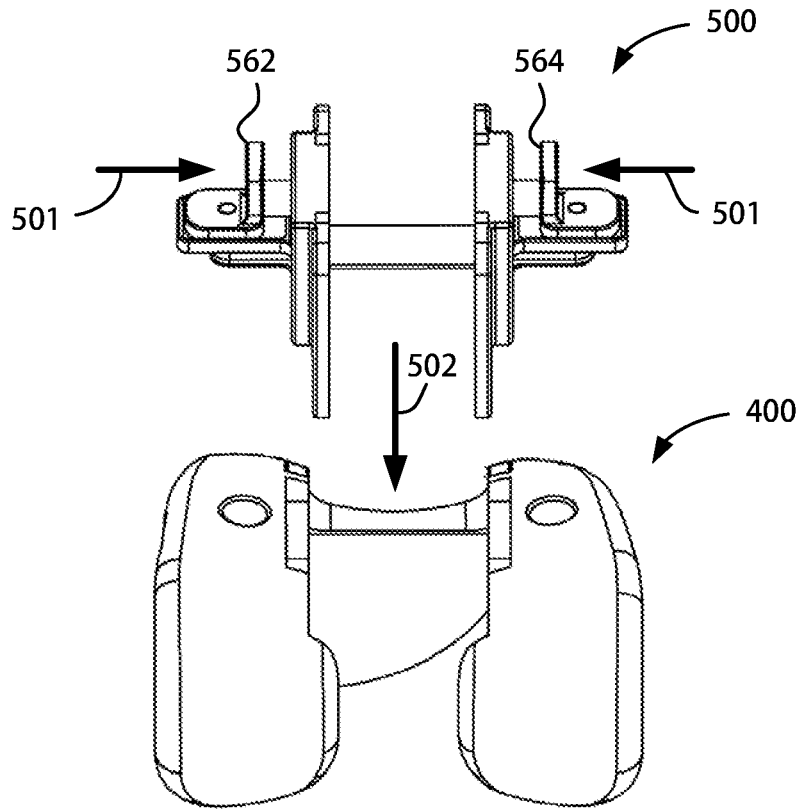

Fig. 27A

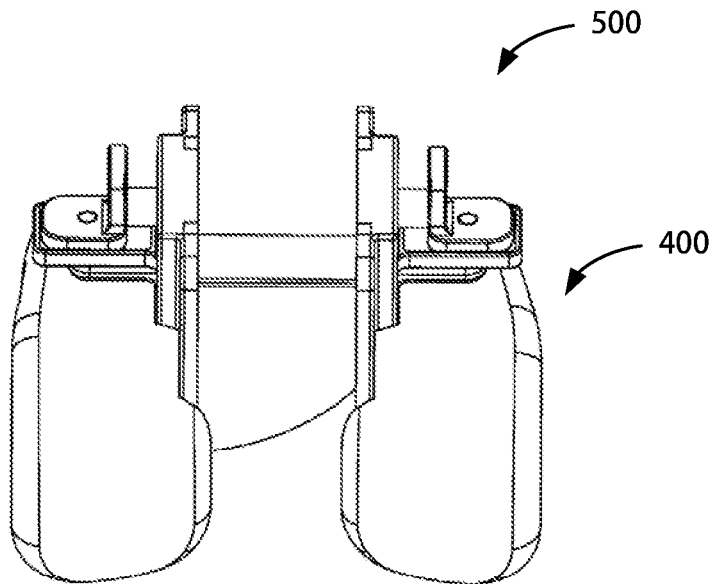

Fig. 27B

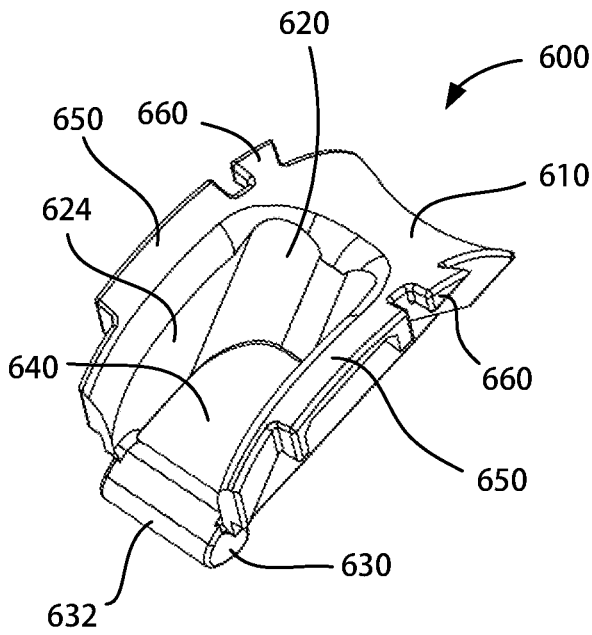

Fig. 28A

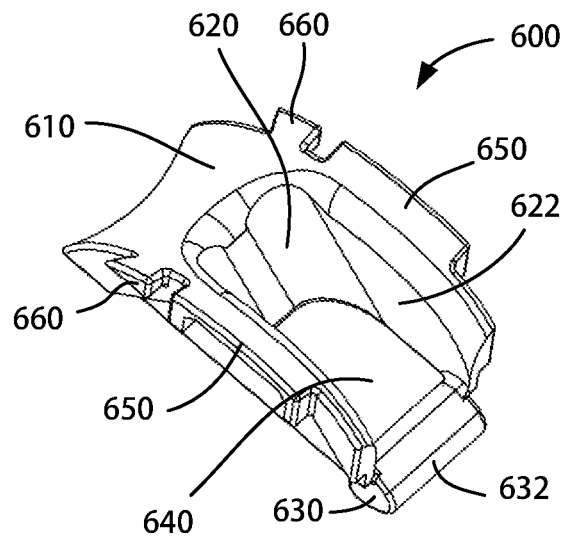

Fig. 28B

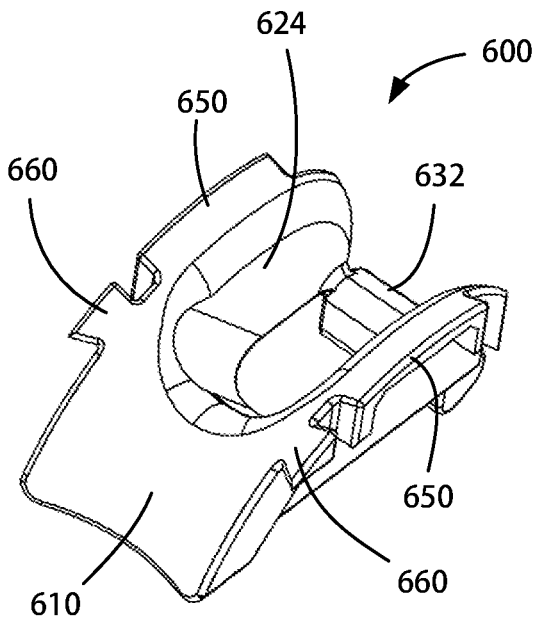

Fig. 28C

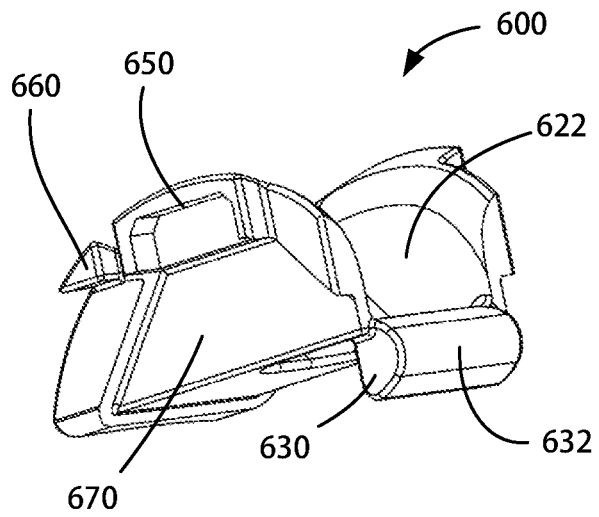

Fig. 28D

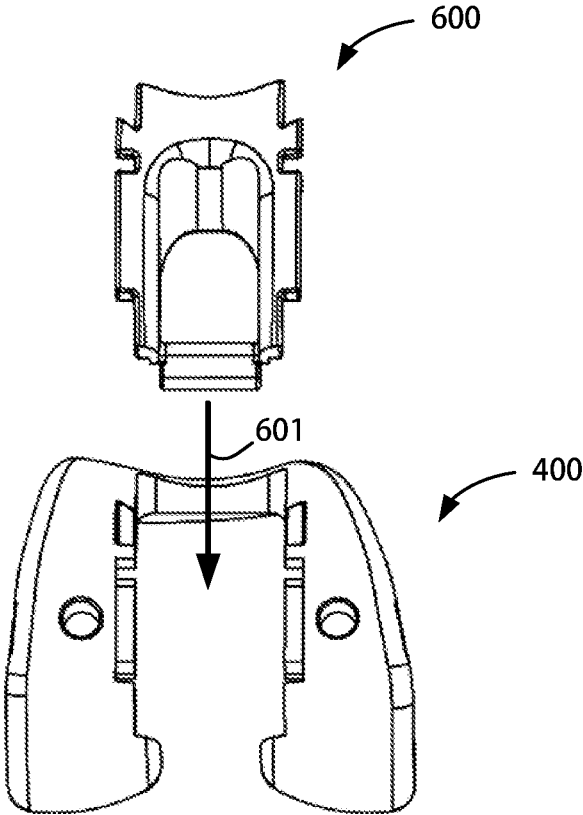

Fig. 29A

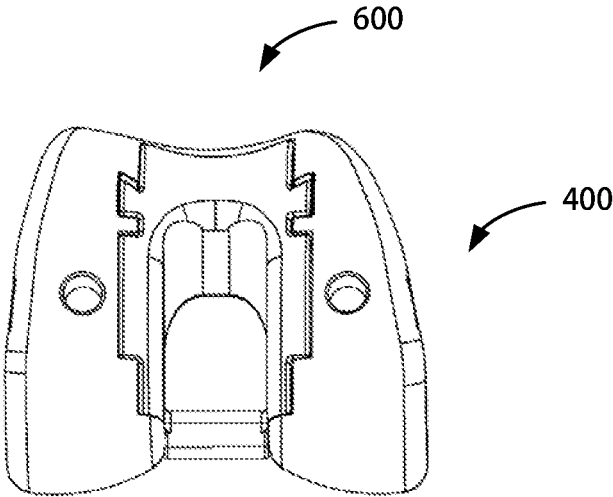

Fig. 29B

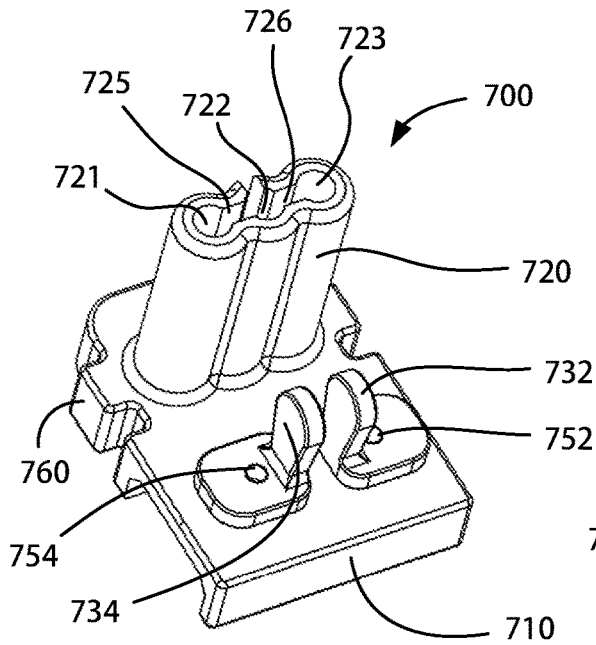

Fig. 30A

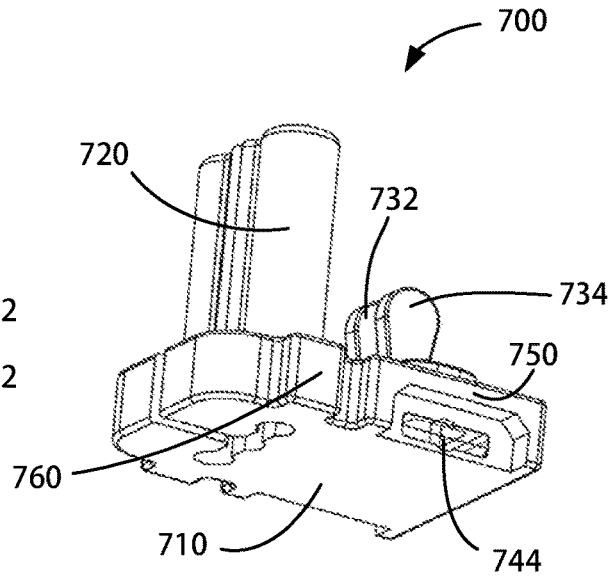

Fig. 30B

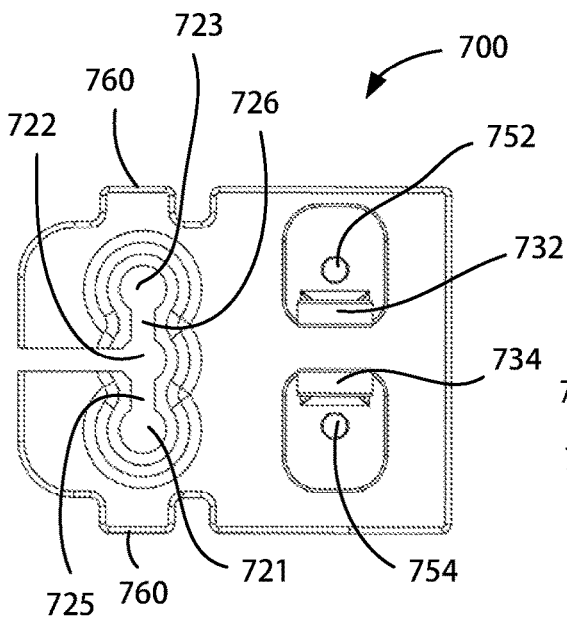

Fig. 30C

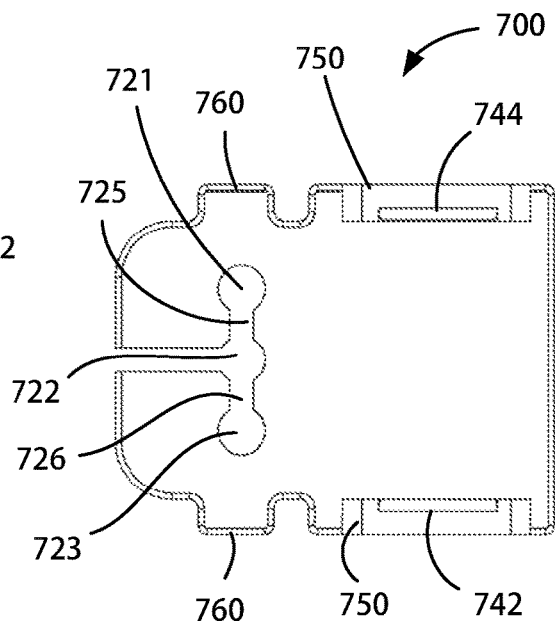

Fig. 30D



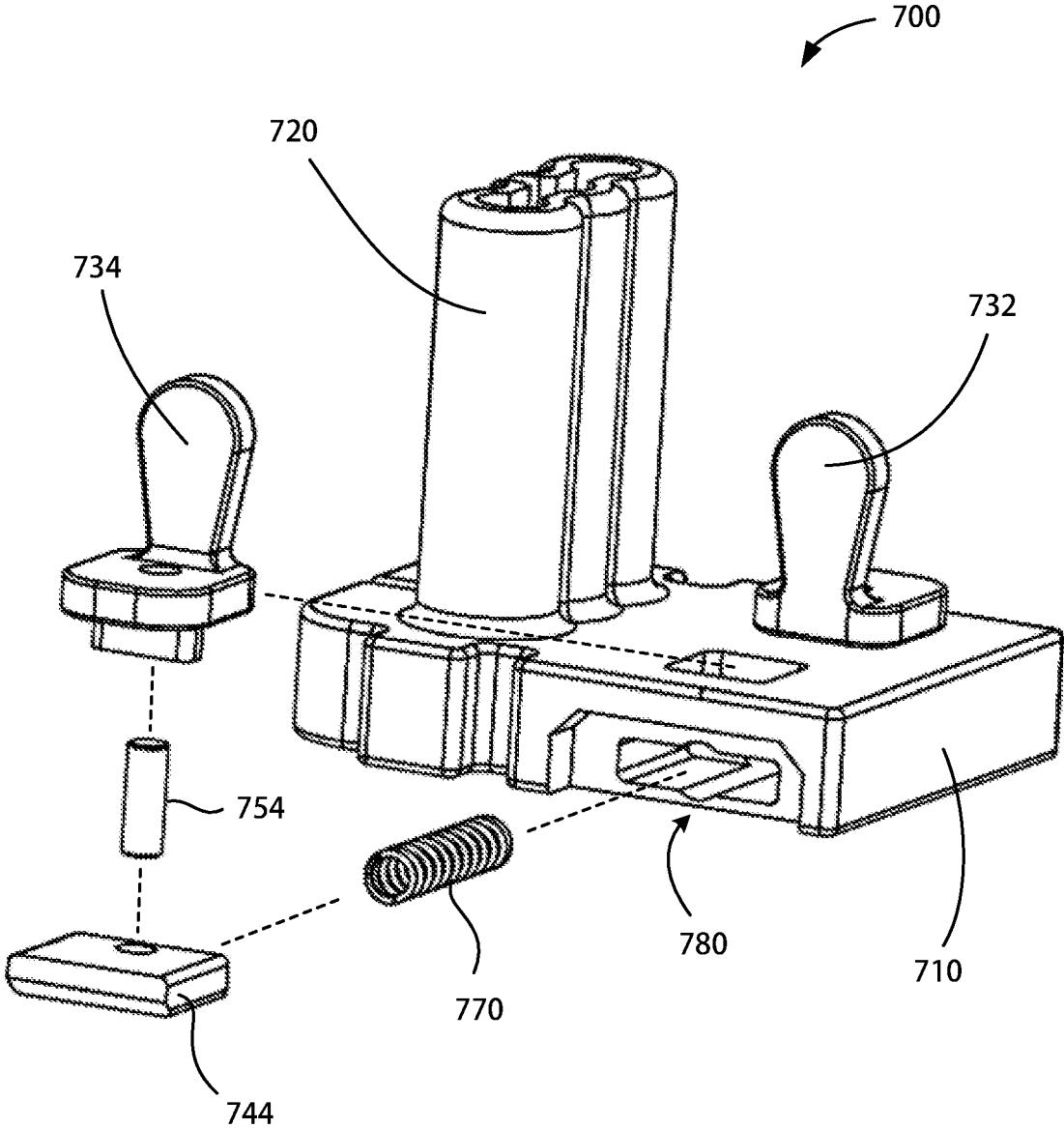

Fig. 31

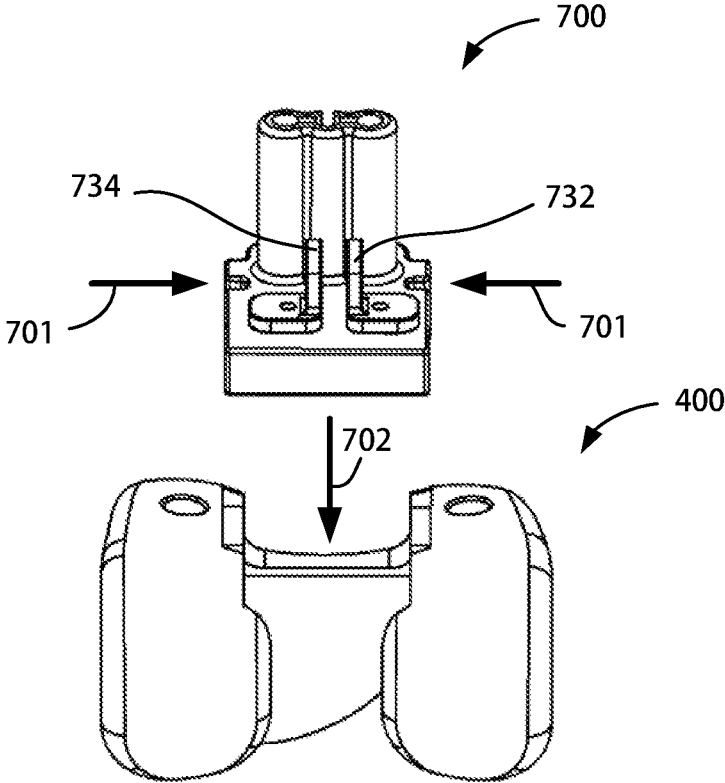

Fig. 32A

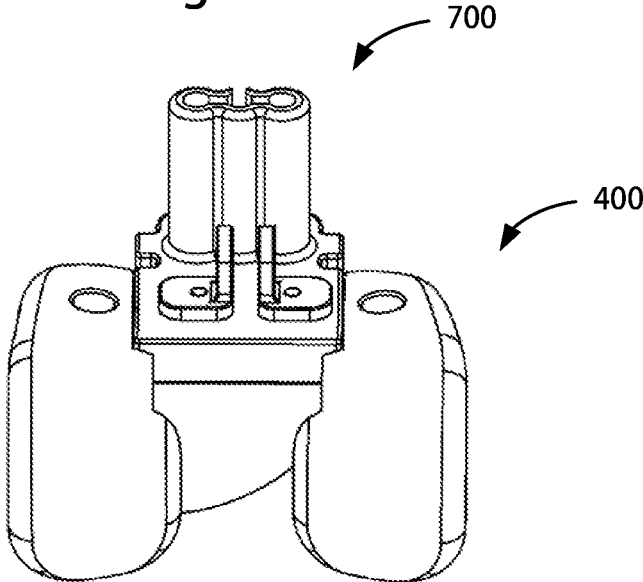

Fig. 32B

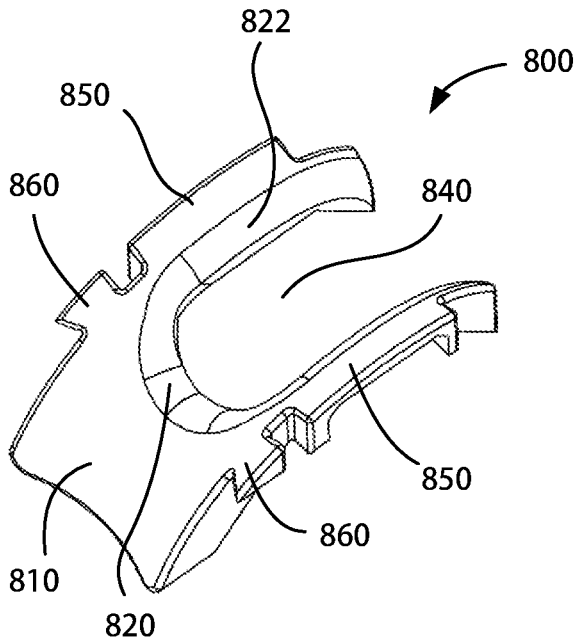

Fig. 33A

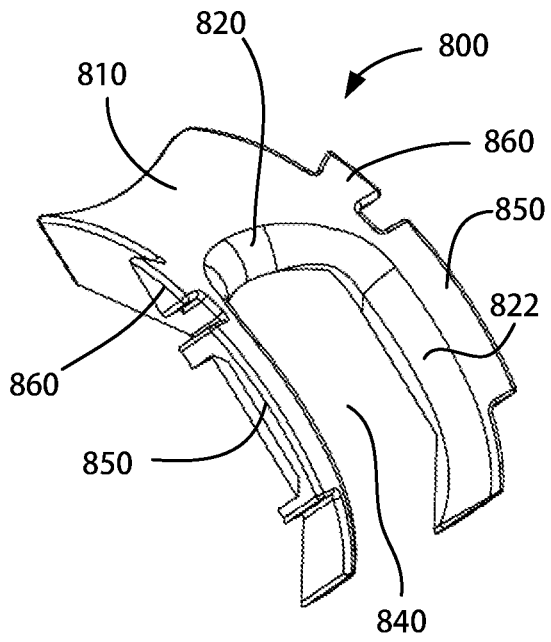

Fig. 33B

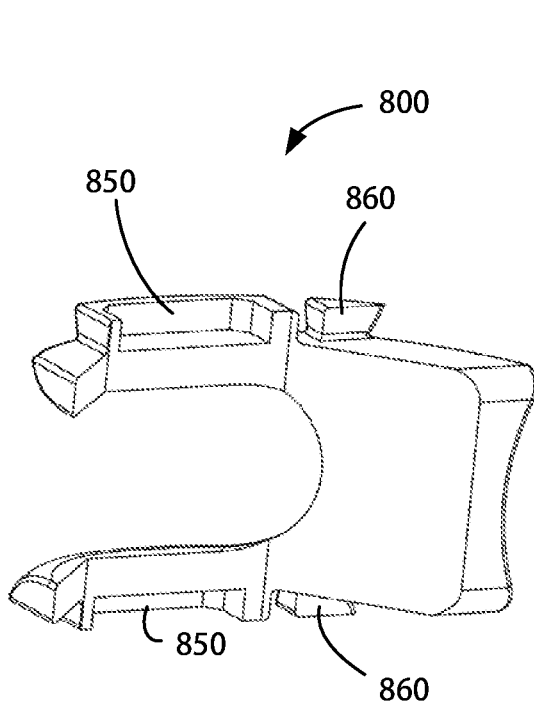

Fig. 33C

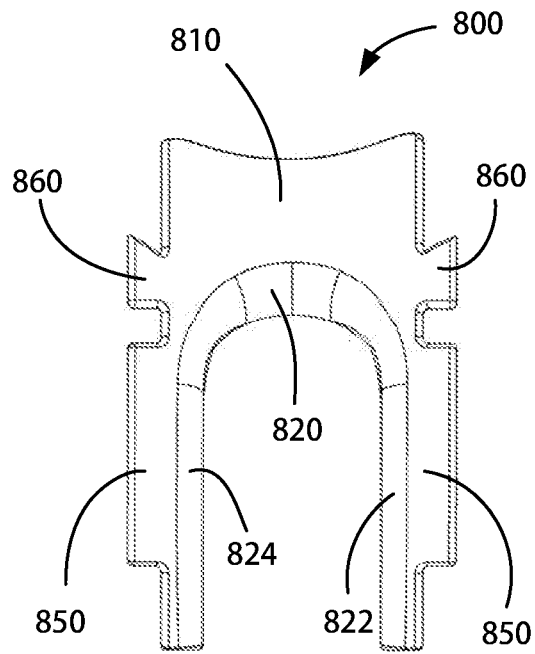

Fig. 33D

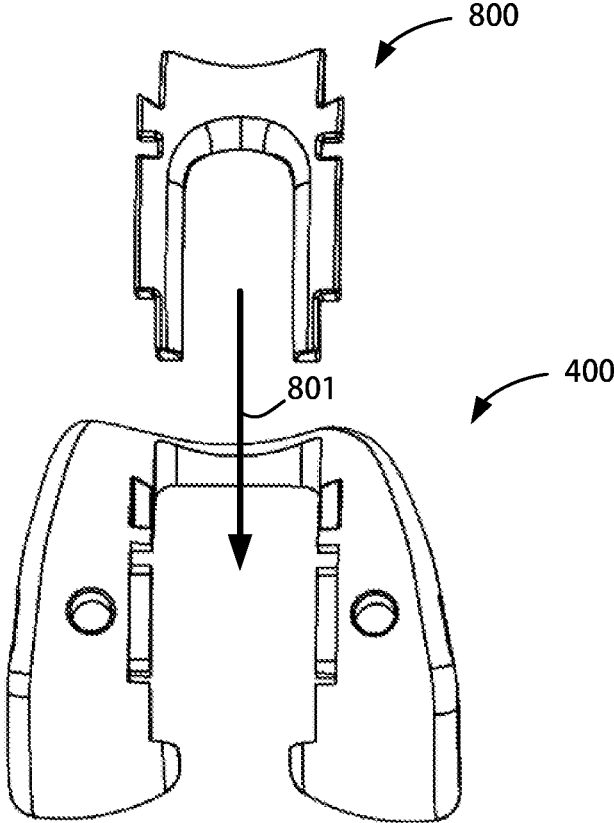

Fig. 34A

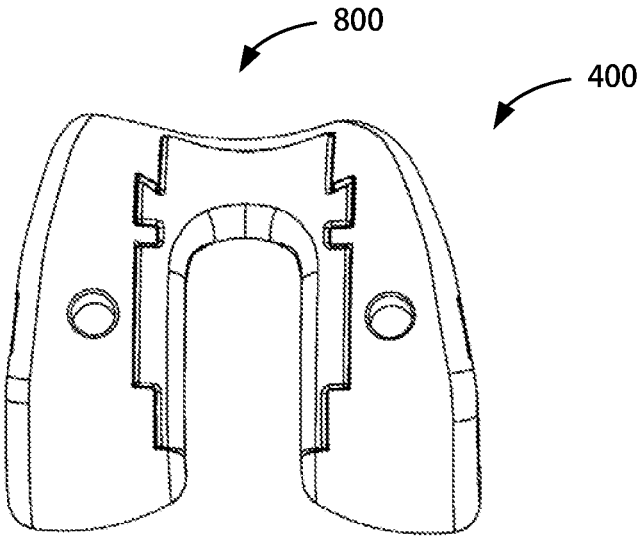

Fig. 34B

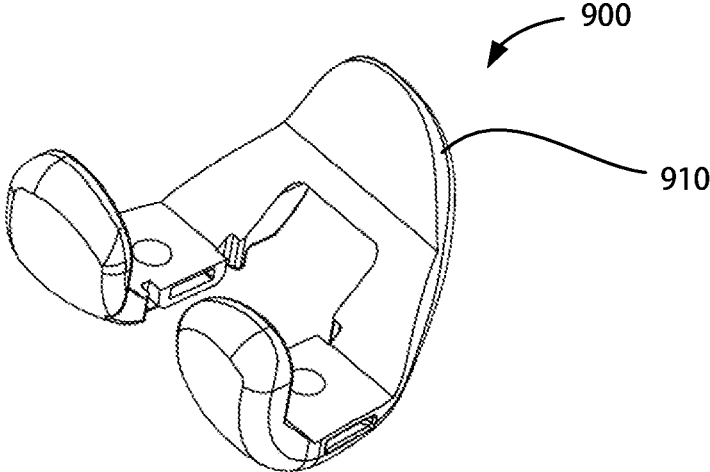

Fig. 35A

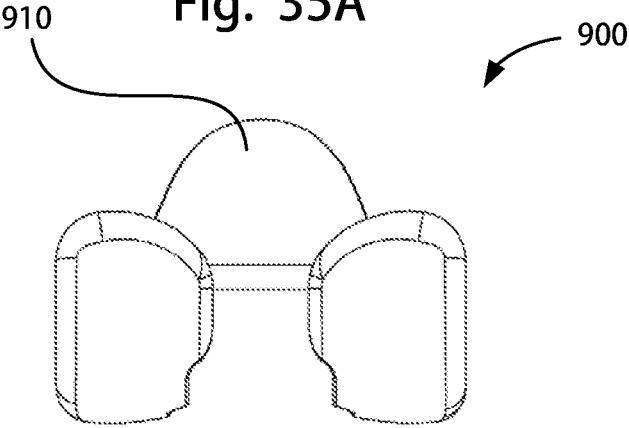

Fig. 35B

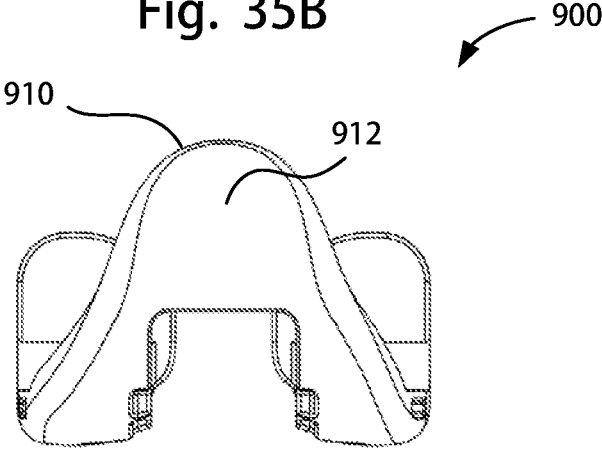

Fig. 35C

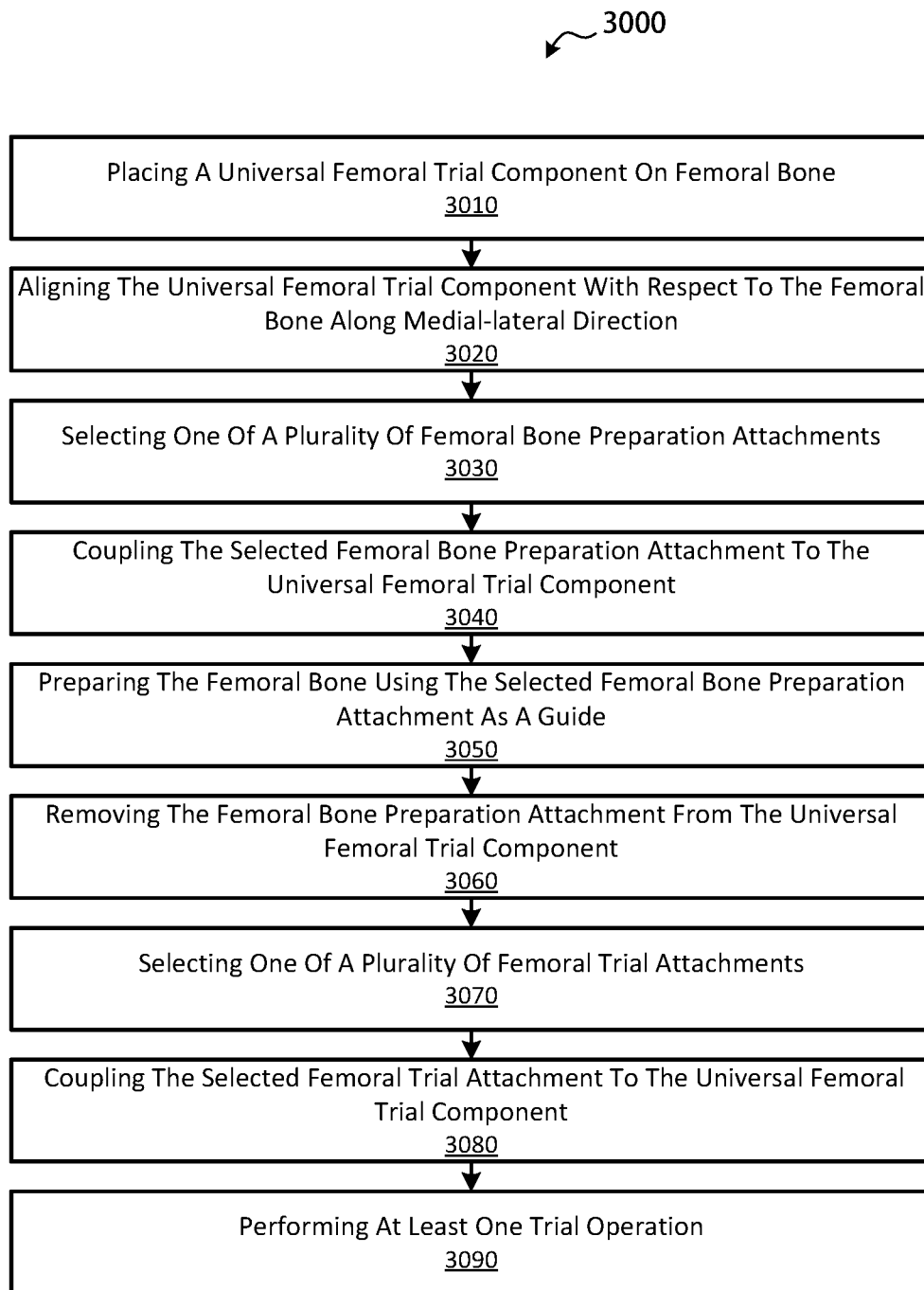

Fig. 36

↙ 4000

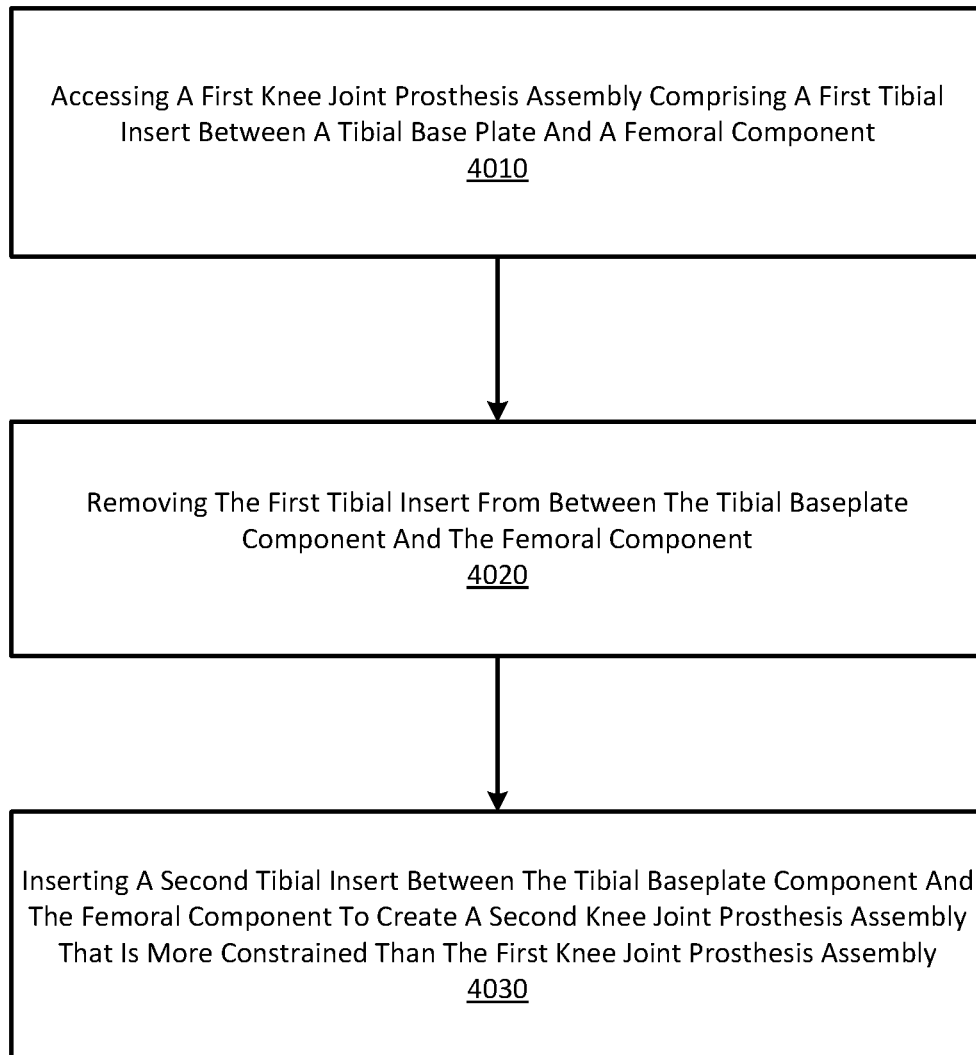

Fig. 37

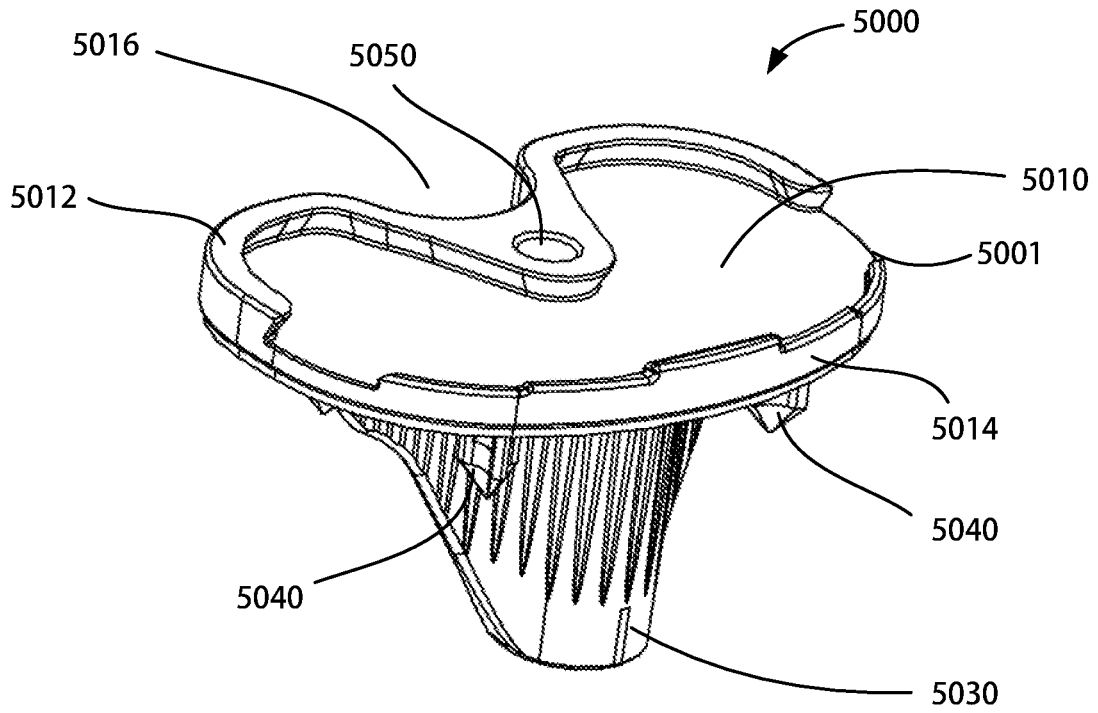

Fig. 38A

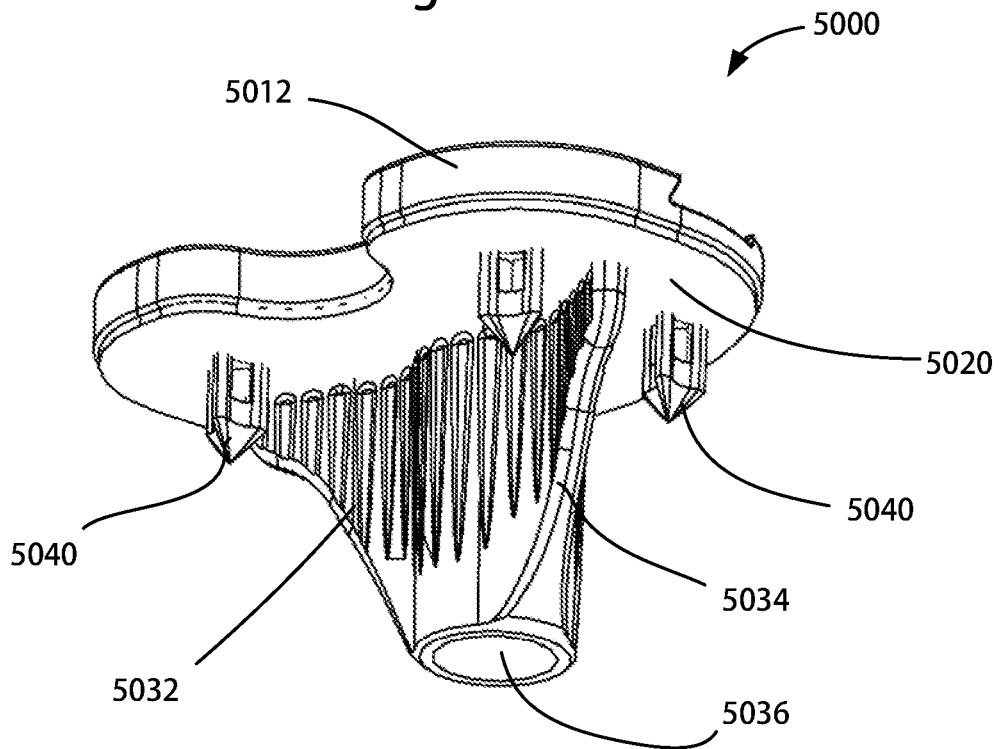

Fig. 38B



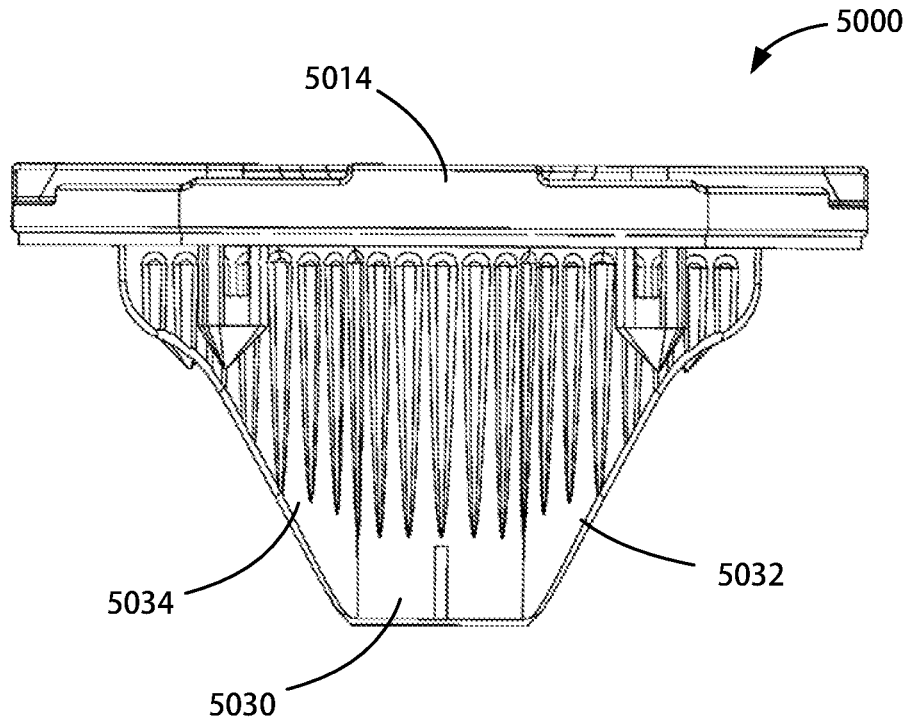

Fig. 38C

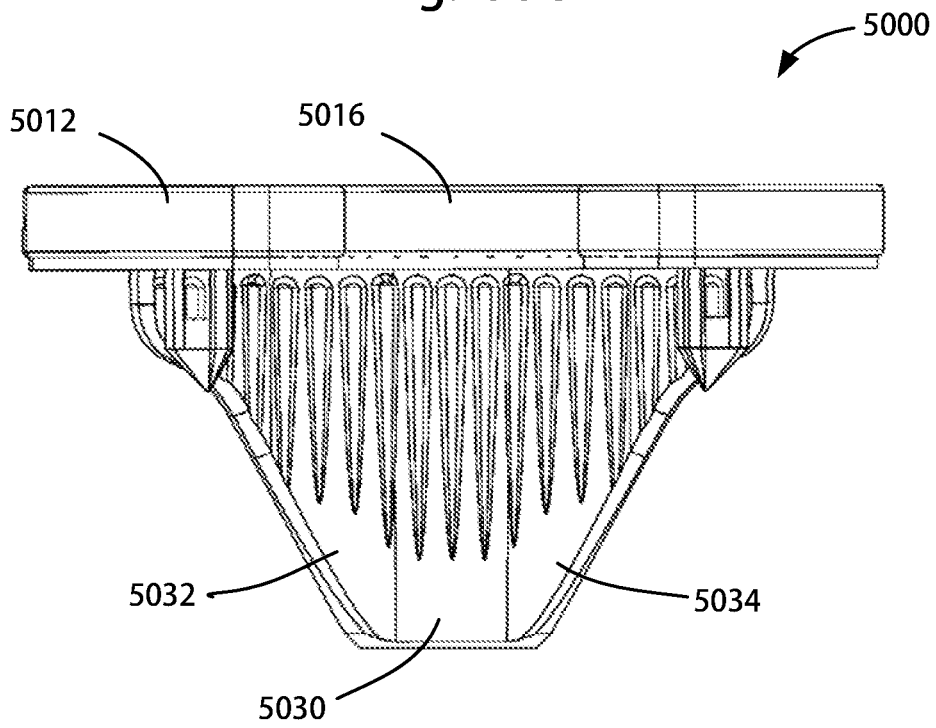

Fig. 38D

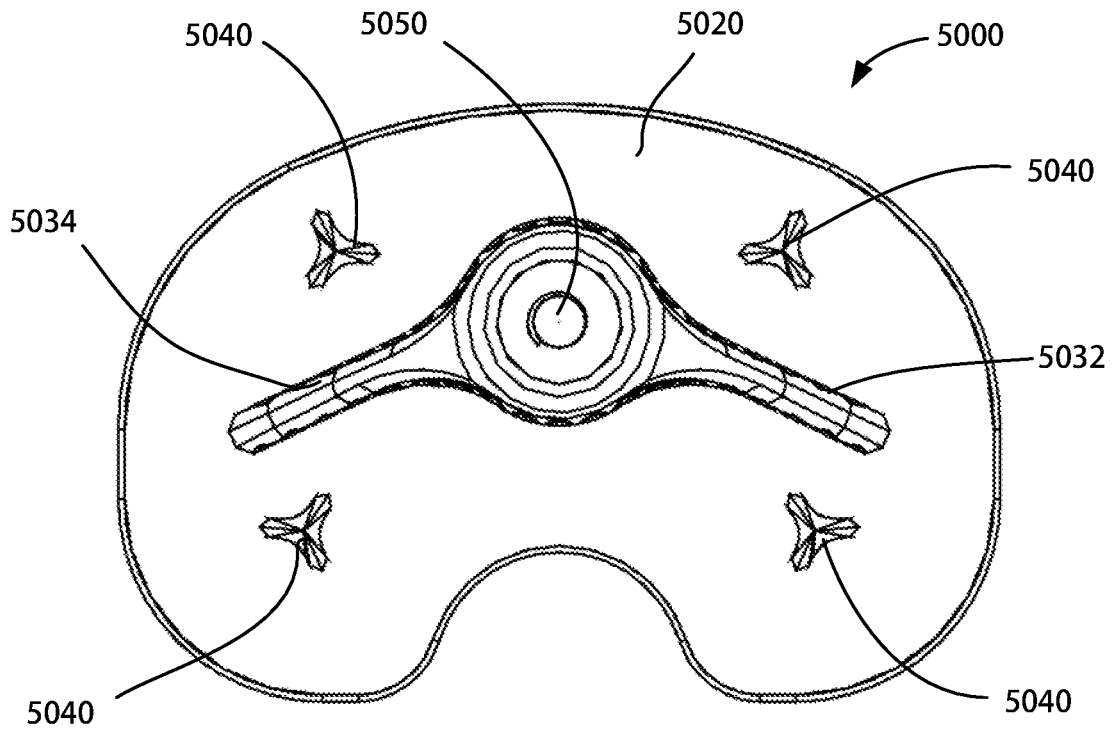

Fig. 38E

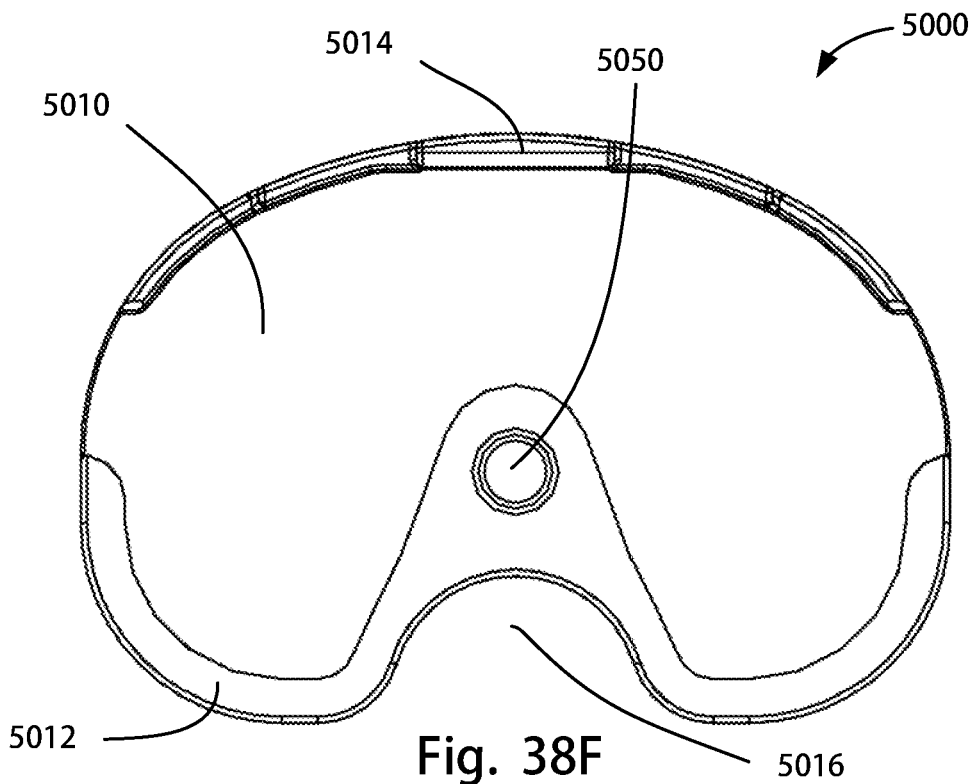

Fig. 38F

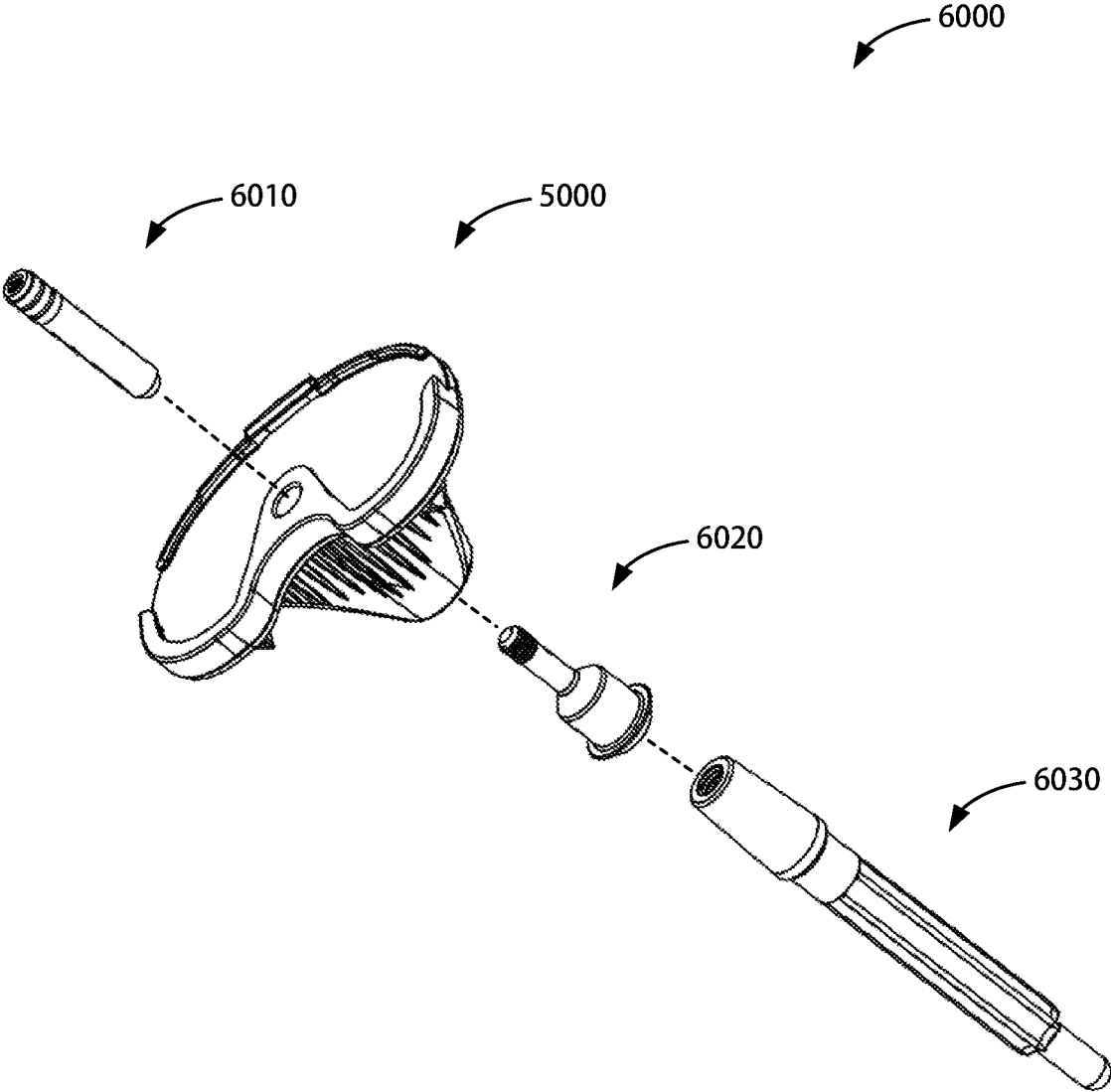

Fig. 39

1

## UNIVERSAL FEMORAL TRIAL SYSTEM AND METHODS

### CROSS-REFERENCE TO RELATED APPLICATIONS

The present application claims the benefit of U.S. Provisional Patent Application Ser. No. 62/537,106, entitled MODULAR KNEE PROSTHESIS, which was filed on Jul. 26, 2017. The above-referenced application is incorporated by reference herein as though set forth in its entirety.

### TECHNICAL FIELD

The present disclosure relates to surgical devices, systems, instruments, and methods. More specifically, the present disclosure relates to orthopedic knee replacement surgical devices, instruments, systems, and methods.

### BACKGROUND

A number of knee replacement options exist which may be implemented depending upon the level of compromise of the natural knee anatomy. The knee anatomy complex includes the knee joint between the femur distal end and the tibia proximal end, and the surrounding anterior and posterior cruciate ligaments (ACL, PCL), and medial and lateral collateral ligaments (MCL, LCL), which provide support and stabilization to the knee joint. When one or more ligaments are compromised, for example through injury, disease, or aging, a knee prosthesis system may be implanted to replace the knee joint.

In a situation where the anterior cruciate ligament is compromised, it may be removed and a cruciate retaining (CR) knee prosthesis system, which allows retention of the posterior cruciate ligament and the collateral ligaments, may be implanted. Typical CR knee prosthesis femoral components and tibial inserts have large U-shaped openings providing room for the extant PCL, MCL, and LCL ligaments.

In a case where both the anterior and posterior cruciate ligaments are compromised but, yet the collateral ligaments are functional, both the ACL and PCL may be removed, and a posterior stabilizing (PS) knee prosthesis system may be implanted. A typical PS tibial insert includes a central post, and many PS femoral components include a cam element extending between the medial and lateral condyles. The post and cam interact to provide stability in place of the removed PCL ligament.

In a case where the anterior and posterior cruciate ligaments are compromised, and the collateral ligaments are unstable, both the ACL and PCL may be removed and a constrained condylar knee (CCK) prosthesis system may be implanted. In a case where all four ligaments are compromised, all ligaments may be removed, and a hinge type knee replacement system may be implanted.

A typical knee prosthesis system includes a tibial bone anchoring component, a tibial articulating component, which may be called a tibial insert, and a femoral bone anchoring component. Since the tibial and femoral bone anchoring components are anchored to bone through various fasteners, cement, and/o bone ingrowth, it may be difficult and invasive to remove and replace either of the bone anchoring components, should the need arise. The tibial insert is typically made of polyethylene, and since it is not anchored to bone, is much more easily replaced if necessary. For example, a patient may have a CR knee prosthesis and then experience compromise of the PCL, thus requiring

2

replacement of the CR knee prosthesis with a PS knee prosthesis. Or, a patient may have a PS knee prosthesis and then experience instability of the collateral ligaments, thus requiring replacement of the PS knee prosthesis with a CCK prosthesis.

### SUMMARY

The various systems and methods of the present disclosure have been developed in response to the present state of the art, and in particular, in response to the problems and needs in the art that have not yet been fully solved by currently available technology.

In some embodiments, a universal femoral trial system for preparing and trialing a femoral bone of a patient to receive a plurality of different femoral implant types may include a universal femoral trial component. The universal femoral trial component may include a medial condyle having a medial condylar articulation surface, a lateral condyle having a lateral condylar articulation surface, and an attachment aperture located intermediate the medial condyle and the lateral condyle. The attachment aperture may be configured to receive any of a plurality of femoral bone preparation attachments comprising at least two of: a posterior stabilizing notch cutting guide assembly, a drill guide assembly, a broach guide assembly, and an augment cutting guide assembly. The plurality of femoral bone preparation attachments may be configured to removably couple to the universal femoral trial component to allow a femoral bone of a patient to be selectively modified and prepared to receive a selected femoral implant type.

The universal femoral trial system may further include a patellar projection located anterior to the medial condyle and the lateral condyle, the patellar projection having a patellar articulation surface and at least one of a symmetrical medial-lateral shape, a right angled medial-lateral shape, and a left angled medial-lateral shape. The attachment aperture may further be configured to receive any of a plurality of femoral trial attachments including at least one of a cruciate retaining trial attachment with a cruciate retaining central portion articulation surface, and a posterior stabilizing trial attachment with a posterior stabilizing central portion articulation surface. The cruciate retaining trial attachment and the posterior stabilizing trial attachment may each be configured to removably couple to the universal femoral trial component and may each provide a central portion articulation surface above the attachment aperture to allow for trialing of an articulation surface for the selected femoral implant type. The articulation surface may include the medial condylar articulation surface, the lateral condylar articulation surface, and the central portion articulation surface, for the selected femoral implant type.

The cruciate retaining trial attachment and the posterior stabilizing trial attachment may each be configured to magnetically couple to the universal femoral trial component.

The posterior stabilizing trial attachment may further have a posterior stabilizing box and a cam bar element comprising a cam bar articulating surface. The posterior stabilizing box and the cam bar element may be configured to allow for trialing of a complete posterior stabilizing femoral implant.

The attachment aperture may further include medial attachment features proximate the medial condyle. The medial attachment features may include at least a medial attachment projection and a medial attachment aperture formed within the medial attachment projection. The attachment aperture may further include lateral attachment features proximate the lateral condyle. The lateral attachment

features may include at least a lateral attachment projection and a lateral attachment aperture formed within the lateral attachment projection.

The posterior stabilizing notch cutting guide assembly may include a posterior stabilizing notch cutting guide body with a medial cutting guide surface, a lateral cutting guide surface, and a patellar cutting guide surface. The posterior stabilizing notch cutting guide assembly may further include a locking mechanism with a first locking member, a second locking member, a first release lever coupled to the first locking member via a first pin, a second release lever coupled to the second locking member via a second pin, a first resilient member located between the first release lever and the posterior stabilizing notch cutting guide body, configured to apply a biasing force to push the first locking member away from the posterior stabilizing notch cutting guide body, and a second resilient member located between the second release lever and the posterior stabilizing notch cutting guide body, configured to apply a biasing force to push the second locking member away from the posterior stabilizing notch cutting guide body. The posterior stabilizing notch cutting guide assembly may be removably coupled to the universal femoral trial component by squeezing the first release lever and the second release lever together toward each other to overcome the biasing forces of the first and second resilient members, inserting the posterior stabilizing notch cutting guide assembly into the attachment aperture formed in the universal femoral trial component, and releasing the first release lever and the second release lever to allow the biasing forces of the first and second resilient members to push the first locking member and the second locking member away from the posterior stabilizing notch cutting guide body, causing the first locking member to enter within the medial attachment aperture and the second locking member to enter within the lateral attachment aperture to couple the posterior stabilizing notch cutting guide assembly to the universal femoral trial component.

The drill guide assembly and the broach guide assembly may be combined together to form a drill and broach guide assembly with a drill and broach guide body with a first drill guide aperture, a second drill guide aperture, a third drill guide aperture, a first broach guide aperture intermediate the first drill guide aperture and the second drill guide aperture; and a second broach guide aperture intermediate the second drill guide aperture and the third drill guide aperture. The second drill guide aperture may be intermediate the first broach guide aperture and the second broach guide aperture. The drill and broach guide assembly may further have a drill and broach guide locking mechanism with a first locking member, a second locking member, a first release lever coupled to the first locking member via a first pin, a second release lever coupled to the second locking member via a second pin, and a resilient member located between the first locking member and the second locking member. The resilient member may be configured to apply a biasing force between the first locking member and the second locking member to push the first locking member and the second locking member away from each other. The drill and broach guide assembly may be removably coupled to the universal femoral trial component by squeezing the first release lever and the second release lever together toward each other to overcome the biasing force of the resilient member between the first locking member and the second locking member, inserting the drill and broach guide assembly into the attachment aperture formed in the universal femoral trial component, and releasing the first release lever and the

second release lever to allow the biasing force of the resilient member to push the first locking member and the second locking member away from each other, causing the first locking member to enter within the medial attachment aperture and the second locking member to enter within the lateral attachment aperture to couple the drill and broach guide assembly to the universal femoral trial component.

In other embodiments, a modular universal femoral trial kit for preparing and trialing a femoral bone of a patient to receive a plurality of different femoral implant types may include a universal femoral trial component. The universal femoral trial component may include a medial condyle having a medial condylar articulation surface, a lateral condyle having a lateral condylar articulation surface, and an attachment aperture located intermediate the medial condyle and the lateral condyle. The attachment aperture may be configured to receive any of a plurality of femoral bone preparation attachments comprising at least two of: a posterior stabilizing notch cutting guide assembly, a drill guide assembly, a broach guide assembly, and an augment cutting guide assembly. The plurality of femoral bone preparation attachments may be configured to removably couple to the universal femoral trial component to allow a femoral bone of a patient to be selectively modified and prepared to receive a selected femoral implant type. The modular universal femoral trial kit may also include a container containing at least the universal femoral trial component and at least one of the plurality of femoral bone preparation attachments.

The modular universal femoral trial kit may further have a patellar projection located anterior to the medial condyle and the lateral condyle, with a patellar articulation surface and at least one of a symmetrical medial/lateral shape, a right angled medial/lateral shape, and a left angled medial/lateral shape. The attachment aperture may further be configured to receive any of a plurality of femoral trial attachments including at least one of a cruciate retaining trial attachment comprising a cruciate retaining central portion articulation surface, and a posterior stabilizing trial attachment comprising a posterior stabilizing central portion articulation surface. The cruciate retaining trial attachment and the posterior stabilizing trial attachment may each be configured to removably couple to the universal femoral trial component and provide a central portion articulation surface above the attachment aperture to allow for trialing of an articulation surface for the selected femoral implant type. The articulation surface may include the medial condylar articulation surface, the lateral condylar articulation surface, and the central portion articulation surface, for the selected femoral implant type.

The cruciate retaining trial attachment and the posterior stabilizing trial attachment may each be configured to magnetically couple to the universal femoral trial component.

The posterior stabilizing trial attachment may further include a posterior stabilizing box, and a cam bar element with a cam bar articulating surface. The posterior stabilizing box and the cam bar element may be configured to allow for trialing of a complete posterior stabilizing femoral implant.

The attachment aperture may further have medial attachment features proximate the medial condyle, including at least a medial attachment projection and a medial attachment aperture formed within the medial attachment projection. The attachment aperture may further have lateral attachment features proximate the lateral condyle, including at least a lateral attachment projection and a lateral attachment aperture formed within the lateral attachment projection.

5

The posterior stabilizing notch cutting guide assembly may have a posterior stabilizing notch cutting guide body with a medial cutting guide surface, a lateral cutting guide surface, and a patellar cutting guide surface. The posterior stabilizing notch cutting guide assembly may further have a locking mechanism with a first locking member, a second locking member, a first release lever coupled to the first locking member via a first pin, a second release lever coupled to the second locking member via a second pin, a first resilient member located between the first release lever and the posterior stabilizing notch cutting guide body, configured to apply a biasing force to push the first locking member away from the posterior stabilizing notch cutting guide body, and a second resilient member located between the second release lever and the posterior stabilizing notch cutting guide body, configured to apply a biasing force to push the second locking member away from the posterior stabilizing notch cutting guide body. The posterior stabilizing notch cutting guide assembly may be removably coupled to the universal femoral trial component by squeezing the first release lever and the second release lever together toward each other to overcome the biasing forces of the first and second resilient members, inserting the posterior stabilizing notch cutting guide assembly into the attachment aperture formed in the universal femoral trial component, and releasing the first release lever and the second release lever to allow the biasing forces of the first and second resilient members to push the first locking member and the second locking member away from the posterior stabilizing notch cutting guide body, causing the first locking member to enter within the medial attachment aperture and the second locking member to enter within the lateral attachment aperture to couple the posterior stabilizing notch cutting guide assembly to the universal femoral trial component.

The drill guide assembly and the broach guide assembly may be combined together to form a drill and broach guide assembly with a drill and broach guide body with a first drill guide aperture, a second drill guide aperture, a third drill guide aperture, a first broach guide aperture intermediate the first drill guide aperture and the second drill guide aperture, and a second broach guide aperture intermediate the second drill guide aperture and the third drill guide aperture. The second drill guide aperture may be intermediate the first broach guide aperture and the second broach guide aperture. The drill and broach guide assembly may further include a drill and broach guide locking mechanism with a first locking member, a second locking member, a first release lever coupled to the first locking member via a first pin, a second release lever coupled to the second locking member via a second pin, and a resilient member located between the first locking member and the second locking member. The resilient member may be configured to apply a biasing force between the first locking member and the second locking member to push the first locking member and the second locking member away from each other. The drill and broach guide assembly may be removably coupled to the universal femoral trial component by squeezing the first release lever and the second release lever together toward each other to overcome the biasing force of the resilient member between the first locking member and the second locking member, inserting the drill and broach guide assembly into the attachment aperture formed in the universal femoral trial component, and releasing the first release lever and the second release lever to allow the biasing force of the resilient member to push the first locking member and the second locking member away from each other, causing the first

6

locking member to enter within the medial attachment aperture and the second locking member to enter within the lateral attachment aperture to couple the drill and broach guide assembly to the universal femoral trial component.

In yet other embodiments, a method of preparing and trialing a femoral bone of a patient with a universal femoral trial component may include placing the universal femoral trial component on an inferior end of a femoral bone of the patient, aligning the universal femoral trial component with respect to the inferior end of the femoral bone of the patient along a medial-lateral direction, selecting one of a plurality of femoral bone preparation attachments, coupling the selected one of the plurality of femoral bone preparation attachments to the universal femoral trial component, and preparing the femoral bone by using the selected one of the plurality of femoral bone preparation attachments as a guide to resect at least a portion of the femoral bone.

The method may further include removing the selected one of the plurality of femoral bone preparation attachments from the universal femoral trial component, selecting one of a plurality of femoral trial attachments, coupling the selected one of the plurality of femoral trial attachments to the universal femoral trial component, and performing at least one trial operation with the selected one of the plurality of femoral trial attachments coupled to the universal femoral trial component. The universal femoral trial component may have a medial condyle comprising a medial condylar articulation surface, a lateral condyle comprising a lateral condylar articulation surface, a patellar projection comprising a patellar articulation surface, the patellar projection located anterior to the medial condyle and the lateral condyle, and an attachment aperture located intermediate the medial condyle and the lateral condyle. The attachment aperture may be configured to receive any of the plurality of femoral bone preparation attachments, including at least two of a posterior stabilizing notch cutting guide assembly, a drill guide assembly, a broach guide assembly, and an augment cutting guide assembly. The attachment aperture may further be configured to receive any of the plurality of femoral trial attachments, including at least one of a cruciate retaining trial attachment comprising a cruciate retaining central portion articulation surface, and a posterior stabilizing trial attachment comprising a posterior stabilizing central portion articulation surface. Each of the plurality of femoral bone preparation attachments may be configured to removably couple to the universal femoral trial component to allow the femoral bone of the patient to be selectively modified and prepared to receive a selected femoral implant type. The cruciate retaining trial attachment and the posterior stabilizing trial attachment may each be configured to removably couple to the universal femoral trial component and provide a central portion articulation surface above the attachment aperture to allow for trialing of an articulation surface for the selected femoral implant type. The articulation surface may include the medial condylar articulation surface, the lateral condylar articulation surface, and the central portion articulation surface, for the selected femoral implant type.

The cruciate retaining trial attachment and the posterior stabilizing trial attachment may each be configured to magnetically couple to the universal femoral trial component. The attachment aperture may further have medial attachment features proximate the medial condyle, including at least a medial attachment projection and a medial attachment aperture formed within the medial attachment projection. The attachment aperture may further have lateral attachment features proximate the lateral condyle, including

at least a lateral attachment projection and a lateral attachment aperture formed within the lateral attachment projection.

The selected one of the plurality of femoral trial attachments may include the cruciate retaining trial attachment and the selected one of the plurality of femoral bone preparation attachments may include a drill and broach guide assembly with a drill and broach guide body having a first drill guide aperture, a second drill guide aperture, a third drill guide aperture, a first broach guide aperture intermediate the first drill guide aperture and the second drill guide aperture, and a second broach guide aperture intermediate the second drill guide aperture and the third drill guide aperture. The second drill guide aperture may be intermediate the first broach guide aperture and the second broach guide aperture. The drill and broach guide body may further include a drill and broach guide locking mechanism with a first locking member, a second locking member, a first release lever coupled to the first locking member via a first pin, a second release lever coupled to the second locking member via a second pin, and a resilient member located between the first locking member and the second locking member. The resilient member may be configured to apply a biasing force between the first locking member and the second locking member to push the first locking member and the second locking member away from each other. The drill and broach guide assembly may be removably coupled to the universal femoral trial component by squeezing the first release lever and the second release lever together toward each other to overcome the biasing force of the resilient member between the first locking member and the second locking member, inserting the drill and broach guide assembly into the attachment aperture formed in the universal femoral trial component, and releasing the first release lever and the second release lever to allow the biasing force of the resilient member to push the first locking member and the second locking member away from each other, causing the first locking member to enter within the medial attachment aperture and the second locking member to enter within the lateral attachment aperture to couple the drill and broach guide assembly to the universal femoral trial component.

The selected one of the plurality of femoral trial attachments may include the posterior stabilizing trial attachment and the selected one of the plurality of femoral bone preparation attachments may include the posterior stabilizing notch cutting guide assembly. The posterior stabilizing notch cutting guide assembly may include a posterior stabilizing notch cutting guide body with a medial cutting guide surface, a lateral cutting guide surface, and a patellar cutting guide surface. The posterior stabilizing notch cutting guide assembly may further have a locking mechanism with a first locking member, a second locking member, a first release lever coupled to the first locking member via a first pin, a second release lever coupled to the second locking member via a second pin, a first resilient member located between the first release lever and the posterior stabilizing notch cutting guide body, the first resilient member configured to apply a biasing force to push the first locking member away from the posterior stabilizing notch cutting guide body, and a second resilient member located between the second release lever and the posterior stabilizing notch cutting guide body, the second resilient member configured to apply a biasing force to push the second locking member away from the posterior stabilizing notch cutting guide body. The posterior stabilizing notch cutting guide assembly may be removably coupled to the universal femoral trial compo-

nent by squeezing the first release lever and the second release lever together toward each other to overcome the biasing forces of the first and second resilient members, inserting the posterior stabilizing notch cutting guide assembly into the attachment aperture formed in the universal femoral trial component, and releasing the first release lever and the second release lever to allow the biasing forces of the first and second resilient members to push the first locking member and the second locking member away from the posterior stabilizing notch cutting guide body, causing the first locking member to enter within the medial attachment aperture and the second locking member to enter within the lateral attachment aperture to couple the posterior stabilizing notch cutting guide assembly to the universal femoral trial component.

#### BRIEF DESCRIPTION OF THE DRAWINGS

The advantages, nature, and additional features of exemplary embodiments of the disclosure will become more fully apparent from the following description and appended claims, taken in conjunction with the accompanying drawings. Understanding that these drawings depict only exemplary embodiments and are, therefore, not to be considered limiting of the disclosure's scope, the exemplary embodiments of the disclosure will be described with additional specificity and detail through use of the accompanying drawings in which:

FIG. 1A is a perspective rear view of an assembly of the disclosure, including a posterior stabilizing femoral component and a tibial insert coupled in extension; FIG. 1B is a perspective front view of the assembly of FIG. 1A in flexion;

FIG. 2 is an exploded view of the assembly of FIG. 1A;

FIG. 3A is a posterior view of the tibial insert of FIG. 1A; FIG. 3B is an anterior view of the tibial insert of FIG. 1A; FIG. 3C is a superior view of the tibial insert of FIG. 1A; FIG. 3D is a medial side view of the tibial insert of FIG. 1A;

FIG. 4 is a top down view of the assembly of FIG. 1A;

FIG. 5 is a top down cross-sectional view of the assembly of FIG. 1A, taken along line B-B in FIG. 6;

FIG. 6 is a posterior cross-sectional view of the assembly of FIG. 1A, taken along line A-A in FIG. 5;

FIG. 7 is a top down cross-sectional view of the assembly of FIG. 1B, taken along line C-C in FIG. 8;

FIG. 8 is a posterior cross-sectional view of the assembly of FIG. 1B, taken along line D-D in FIG. 7;

FIG. 9 is a perspective rear view of an assembly of the disclosure, including a cruciate retaining femoral component and the tibial insert of FIG. 1A coupled in extension;

FIG. 10 is an exploded perspective rear view of the assembly of FIG. 9;

FIG. 11A is a perspective rear view of another tibial insert of the disclosure; FIG. 11B is a top view of the tibial insert of FIG. 11A; FIG. 11C is a posterior view of the tibial insert of FIG. 11A; FIG. 11D is an anterior view of the tibial insert of FIG. 11A; FIG. 11E is a bottom view of the tibial insert of FIG. 11A;

FIG. 12A is a perspective rear view of another tibial insert of the disclosure; FIG. 12B is a top view of the tibial insert of FIG. 12A; FIG. 12C is a bottom view of the tibial insert of FIG. 12A; FIG. 12D is a posterior view of the tibial insert of FIG. 12A; FIG. 12E is an anterior view of the tibial insert of FIG. 12A; FIG. 12F is a medial side view of the tibial insert of FIG. 12A;

FIG. 13 is a chart demonstrating the interchangeability of the tibial inserts disclosed herein with various femoral components;

FIG. 14 is an exploded rear view of another assembly of the disclosure, including a posterior stabilizing femoral component and a posterior stabilizing tibial insert;

FIG. 15 is another exploded rear view of the assembly of FIG. 14;

FIG. 16A is a posterior view of the tibial insert of FIG. 14; FIG. 16B is an anterior view of the tibial insert of FIG. 14; FIG. 16C is a superior view of the tibial insert of FIG. 14; FIG. 16D is a medial side view of the tibial insert of FIG. 14;

FIG. 17 is an exploded rear view of another assembly of the disclosure, including a cruciate retaining femoral component with a keel and the posterior stabilizing tibial insert of FIG. 14;

FIG. 18 is another exploded rear view of the assembly of FIG. 17;

FIG. 19 is an exploded rear view of another assembly of the disclosure, including a cruciate retaining femoral component without a keel and the posterior stabilizing tibial insert of FIG. 14;

FIG. 20 is another exploded rear view of the assembly of FIG. 19;

FIG. 21A is a perspective rear view of another tibial insert of the disclosure; FIG. 21B is a top view of the tibial insert of FIG. 21A; FIG. 21C is a posterior view of the tibial insert of FIG. 21A; FIG. 21D is an anterior view of the tibial insert of FIG. 21A; FIG. 21E is a bottom view of the tibial insert of FIG. 21A;

FIG. 22A is a perspective rear view of another tibial insert of the disclosure; FIG. 22B is a top view of the tibial insert of FIG. 22A; FIG. 22C is a bottom view of the tibial insert of FIG. 22A; FIG. 22D is a posterior view of the tibial insert of FIG. 22A; FIG. 22E is an anterior view of the tibial insert of FIG. 22A; FIG. 22F is a medial side view of the tibial insert of FIG. 22A;

FIG. 23A is a perspective front view of the femoral component of FIG. 14 coupled to one or more augments of the present disclosure; FIG. 23B is a medial side view of the femoral component of FIG. 23A;

FIG. 24A is a perspective top view of a femoral trial component of the disclosure; FIG. 24B is a perspective rear view of the femoral trial component of FIG. 24A; FIG. 24C is a lateral side view of the femoral trial component of FIG. 24A; FIG. 24D is a medial side view of the femoral trial component of FIG. 24A; FIG. 24E is an anterior view of the femoral trial component of FIG. 24A; FIG. 24F is a posterior view of the femoral trial component of FIG. 24A; FIG. 24G is a superior view of the femoral trial component of FIG. 24A; FIG. 24H is an inferior view of the femoral trial component of FIG. 24A;

FIG. 25A is a perspective rear view of a posterior stabilizing notch cutting guide assembly of the disclosure; FIG. 25B is another perspective rear view of the posterior stabilizing notch cutting guide assembly of FIG. 25A; FIG. 25C is a medial side view of the posterior stabilizing notch cutting guide assembly of FIG. 25A; FIG. 25D is a top view of the posterior stabilizing notch cutting guide assembly of FIG. 25A;

FIG. 26 is a partial exploded view of the posterior stabilizing notch cutting guide assembly of FIG. 25A;

FIG. 27A is a posterior view of the posterior stabilizing notch cutting guide assembly of FIG. 25A above the femoral trial component of FIG. 24A; FIG. 27B is posterior view of the posterior stabilizing notch cutting guide assembly of FIG. 27A coupled to the femoral trial component of FIG. 27A;

FIG. 28A is a perspective rear view of a posterior stabilizing trial attachment of the disclosure; FIG. 28B is another

perspective rear view of the posterior stabilizing trial attachment of FIG. 28A; FIG. 28C is a perspective front view of the posterior stabilizing trial attachment of FIG. 28A; FIG. 28D is a perspective side view of the posterior stabilizing trial attachment of FIG. 28A;

FIG. 29A is a posterior view of the posterior stabilizing trial attachment of FIG. 28A above the femoral trial component of FIG. 24A; FIG. 29B is a posterior view of the posterior stabilizing trial attachment of FIG. 29A coupled to the femoral trial component of FIG. 29A;

FIG. 30A is a perspective rear view of a drill and broach guide assembly of the disclosure; FIG. 30B is a perspective bottom view of the drill and broach guide assembly of FIG. 30A; FIG. 30C is a top view of the drill and broach guide assembly of FIG. 30A; FIG. 30D is a bottom view of the drill and broach guide assembly of FIG. 30A;

FIG. 31 is a partial exploded view of the drill and broach guide assembly of FIG. 30A;

FIG. 32A is a posterior view of the drill and broach guide assembly of FIG. 30A above the femoral trial component of FIG. 24A; FIG. 32B is a posterior view of the drill and broach guide assembly of FIG. 32A coupled to the femoral trial component of FIG. 32A;

FIG. 33A is a perspective front view of a cruciate retaining trial attachment of the disclosure; FIG. 33B is a perspective rear view of the cruciate retaining trial attachment of FIG. 33A; FIG. 33C is a perspective bottom view of the cruciate retaining trial attachment of FIG. 33A; FIG. 33D is a top view of the cruciate retaining trial attachment of FIG. 33A;

FIG. 34A is a posterior view of the cruciate retaining trial attachment of FIG. 33A above the femoral trial component of FIG. 24A; FIG. 34B is a posterior view of the cruciate retaining trial attachment of FIG. 34A coupled to the femoral trial component of FIG. 34A;

FIG. 35A is a perspective rear view of another femoral trial component of the disclosure; FIG. 35B is a posterior view of the femoral trial component of FIG. 35A; FIG. 35C is an anterior view of the femoral trial component of FIG. 35A;

FIG. 36 is a flow chart diagram of a method for preparing and trialing a femoral bone with a femoral trial component;

FIG. 37 is a flow chart diagram of a method for revising a knee joint prosthesis to provide increased stability;

FIG. 38A is a perspective front view of a tibial tray of the disclosure; FIG. 38B is a perspective rear view of the tibial tray of FIG. 38A; FIG. 38C is an anterior view of the tibial tray of FIG. 38A; FIG. 38D is a posterior view of the tibial tray of FIG. 38A; FIG. 38E is a bottom view of the tibial tray of FIG. 38A; FIG. 38F is a top view of the tibial tray of FIG. 38A; and

FIG. 39 is an exploded view of a tibial tray mounting system of the disclosure that utilizes the tibial tray of FIG. 38A.

It is to be understood that the drawings are for purposes of illustrating the concepts of the disclosure and may not be to scale. Furthermore, the drawings illustrate exemplary embodiments and do not represent limitations to the scope of the disclosure.

#### DETAILED DESCRIPTION

Exemplary embodiments of the disclosure will be best understood by reference to the drawings, wherein like parts are designated by like numerals throughout. It will be readily understood that the components of the disclosure, as generally described and illustrated in the Figures herein, could



be arranged and designed in a wide variety of different configurations. Thus, the following more detailed description of the embodiments of the apparatus, instruments, systems, and methods, as represented in the Figures, is not intended to limit the scope of the disclosure, as claimed, but is merely representative of exemplary embodiments of the disclosure.

Disclosed herein are components for a modular knee prosthesis system. This system may allow for revision procedures by replacement of only the tibial insert, allowing the originally implanted femoral and tibial anchoring components to remain implanted. The system may include CR tibial inserts, PS tibial inserts, and/or CCK tibial inserts. Any one of these tibial inserts may be interchangeably used with CR and/or PS femoral components disclosed herein to provide the stabilization needed to substitute for compromised or removed ligaments. The system may be used with any suitable tibial baseplate component, or tibial tray, to support the tibial insert. The PS tibial inserts disclosed herein may include tapered posts that permit the inserts to be used with cruciate retaining (CR) femoral components and/or posterior stabilizing (PS) femoral components.

Referring to FIGS. 1A-2, an assembly 10 for an implantable knee prosthesis is shown including a femoral component 14 and a tibial insert 12. The femoral component 14 and tibial insert 12 are shown coupled in extension in FIG. 1A, coupled in flexion in FIG. 1B, and shown in an exploded view in FIG. 2. The tibial insert 12 may be further coupled to a tibial baseplate component (not shown) which may be implanted in a prepared tibia of a patient (also not shown). The femoral component 14 and tibial insert 12 illustrated in FIGS. 1A-2 are right femoral and tibial insert components. Left femoral and tibial insert components (not shown) would be mirror images of the right femoral and tibial insert components shown in FIGS. 1A-2. The femoral component 14 may also be referred to as a posterior stabilizing femoral component 14 (or "PS femoral component") and the tibial insert 12 may also be referred to as a posterior stabilizing tibial insert (or "PS insert").

FIGS. 3A-3D show the PS insert 12 of FIGS. 1A-2 in isolation. The PS insert 12 may include a fixation side 20, which may be an inferior side, opposite an articulation side 22, which may be a superior side. The articulation side 22 may include a medial articulation portion 24 having a medial condylar articulation surface 25 and a lateral articulation portion 26 having a lateral condylar articulation surface 27. A central portion 28 may separate the medial articulation portion 24 from the lateral articulation portion 26. A post 30 may protrude superiorly from the central portion 28 and extend from a post base 38 to a post top or post superior end 40. From the anterior perspective (shown in FIG. 3B) and/or the posterior perspective (shown in FIG. 3A), the post 30 may have its maximum medial-lateral or horizontal width toward the post superior end 40 of the post 30, and its minimum medial-lateral or horizontal width toward the post base 38 of the post 30. The post 30 may also be bilaterally symmetrical from the anterior and/or posterior perspectives. A recess 45 may be formed posterior to the central portion 28, between the medial and lateral articulation portions 24, 26, and may provide room for a posterior cruciate ligament (not shown). The PS insert 12 may further include an insert base 46, which may further include an engagement feature 48 for engagement with a tibial baseplate component.

Continuing with FIGS. 1A-3D, the post 30 may have an articulation surface 31 extending around the post 30 on the medial, posterior, lateral, and anterior aspects of the post 30. The articulation surface 31 may include a medial articulation

surface 32, a lateral articulation surface 34, an anterior post surface 36, and a posterior articulation surface 42. The medial and lateral articulation surfaces 32, 34 may be non-parallel to one another and taper inward from the post superior end 40 to the post base 38 relative to an insert midline vertical axis 2, as shown in FIGS. 3A and 3B. As shown in FIG. 3A, an angle  $\theta$  between the vertical axis 2 and each tapered surface 32, 34 may be about 6.5°, in at least one embodiment. Since the post 30 may be bilaterally symmetrical, the angle  $\theta$  may be the same on both the medial and lateral articulation surfaces 32, 34 of the post 30. In other embodiments of the disclosure, angle  $\theta$  may range from about 6° to 11° degrees. The medial articulation surface 32 may be continuous with the medial condylar articulation surface 25, and the lateral articulation surface 34 may be continuous with the lateral condylar articulation surface 27, as can be further seen in cross-section in FIGS. 6 and 8. The anterior post surface 36 may extend between the medial and lateral articulation surfaces 32, 34 and may be convexly rounded. The anterior post surface 36 may also taper outward from the post superior end 40 to the post base 38 relative to the midline vertical axis 2, as best seen in FIG. 3D. In other embodiments of the PS insert 12, the anterior post surface 36 may include less or no taper.

Referring to FIG. 3C, the boundary of the post superior end 40 defines a rounded rim 44 shaped as a portion of a circle defined by a circular envelope 47, as seen from a superior perspective. The post superior end 40 and rim 44 may be crescent-shaped with a concave recess toward a posterior end of the post 30 as shown, and may permit passage of the posterior cruciate ligament. The post superior end 40 may be circular; the rim 44 may provide increased rotational range of motion and surface contact against the femoral component 14 in comparison to traditional posts with a more square or rectangular shape and no rim. Thus, the rounded post superior end 40 and rim 44 may allow for surface contact with the femoral component 14 in contrast to the mere point or edge contact that is achieved by traditional posts that do not have these features.

The PS femoral component 14 depicted in FIGS. 1-8 may include a cam element or cam bar 50 and a box structure 52 for providing posterior stabilization in place of absent ligaments. The cam bar 50 may include a cam articulating surface 51 which may contact the posterior articulation surface 42 of the post 30 during flexion, as in FIGS. 1B and 7. An internal articulation surface 54 may reside on the inside of the box structure 52 and may contact the post 30 during articulation and rotation of the knee joint. The internal articulating surface 54 may be concavely curved, and may contact the rim 44 of the post 30 during axial rotation of the knee joint about the post. The PS femoral component 14 may further include a medial condyle 60 having a medial condylar articulation surface 62, and a lateral condyle 64 having a lateral condylar articulation surface 66. The medial and lateral condylar articulation surfaces 62, 66 may articulate against the PS insert 12 medial and lateral condylar articulation surfaces 25, 27 respectively. A gap 68 may be formed between the medial and lateral condyles 60, 64, with the cam bar 50 extending medial-laterally across the gap 68. The internal articulation surface 54 may include a medial portion 70 continuous with a lateral portion 72. In the embodiment depicted, a fixation post 74 may protrude superiorly from the PS femoral component 14. However, in other embodiments of the PS femoral component 14, the fixation post 74 may be absent and/or other fixation features such as posts, spikes, pegs,

13

webs, keels or teeth may be present to affix the PS femoral component **14** to a prepared femur (not shown).

Referring to FIGS. **9** and **10**, another assembly **110** embodiment of the disclosure may include the PS insert **12** of FIGS. **1-8** coupled with a cruciate retaining femoral component **114** (or “CR femoral component”). The CR femoral component **114** may include medial and lateral condyles **160**, **164**, with a gap **168** formed between the medial and lateral condyles **160**, **164**. As a CR femoral component **114**, no cam bar or box may be present. The medial and lateral condyles **160**, **164** may include medial and lateral condylar articulation surfaces **162**, **166**, and an internal articulation surface **154** with medial and lateral articulating surfaces **170**, **172**.

The medial and lateral articulation surfaces **32**, **34** of the post **30** may be tapered and may permit natural articulation of the CR femoral component **114** with the PS insert **12**, which may not be achievable if the post **30** were not tapered. For example, if the post **30** had straight sides instead of tapered sides, the wider width of the post **30** at the base of the post **30** would interfere with the internal articulating surfaces **170**, **172** of the medial and lateral condyles **160**, **164**. When the PS femoral component **14** is coupled with the PS insert **12** to form assembly **10**, as in FIG. **1A** and FIG. **4**, the circular shape of the post superior end **40** in combination with the tapered medial and lateral articulation surfaces **32**, **34** of the post **30**, may permit the PS femoral component **14** to articulate relative to the PS insert **12** in the manner of a posterior stabilized femoral component. However, when the PS insert **12** is paired and implanted with the CR femoral component **114**, the resultant assembly **110** may provide the native articulation and rotation of a cruciate retaining implant.

Referring to FIGS. **11A-11E**, an alternative embodiment of a tibial insert **212** is shown. Tibial insert **212** may be referred to as a cruciate retaining tibial insert **212** (or “CR insert”). In a system of the disclosure, CR insert **212** may be implanted with the CR femoral component **114** and a tibial baseplate component (not shown) to form a cruciate retaining knee prosthesis system. The CR insert **212** may include a fixation side **220**, which may be an inferior side, opposite an articulation side **222**, which may be a superior side. The articulation side **222** may include a medial articulation portion **224** having a medial condylar articulation surface **225** and a lateral articulation portion **226** having a lateral condylar articulation surface **227**. A central portion **228** may separate the medial articulation portion **224** from the lateral articulation portion **226**. A recess **245** may be formed posterior to the central portion **228**, between the medial and lateral articulation portions **224**, **226**, and may provide room for a posterior cruciate ligament. The CR insert **212** may further include an insert base **246** and an engagement feature **248** for engagement with a tibial baseplate component. The CR insert **212** may be coupled with the CR femoral component **114** to form a cruciate retaining assembly. This assembly may be implanted with a suitable tibial baseplate as a cruciate retaining knee prosthesis. The CR insert **212** may also be coupled with the PS femoral component **14** and implanted with a suitable tibial baseplate.

Referring to FIGS. **12A-12F**, another alternative embodiment of a tibial insert **312** is shown. The tibial insert **312** may be referred to as a constrained condylar knee (CCK) tibial insert **312** (or “CCK insert”). The CCK insert **312** may include a fixation side **320**, which may be an inferior side, opposite an articulation side **322**, which may be a superior side. The articulation side **322** may include a medial articulation portion **324** having a medial condylar articulation

14

surface **325** and a lateral articulation portion **326** having a lateral condylar articulation surface **327**. A central portion **328** may separate the medial articulation portion **324** from the lateral articulation portion **326**. A post **330** may protrude superiorly from the central portion **328**, and extend from a post base **338** to a top, or post superior end **340**. From the anterior perspective, as shown in FIG. **12E**, and the posterior perspective, as shown in FIG. **12D**, the post **330** may have its maximum medial-lateral or horizontal width at the superior end **340** of the post **330**, and its minimum medial-lateral or horizontal width at the post base **338** of the post **330**. The post **330** may be bilaterally symmetrical from the anterior and posterior perspectives. The CCK insert **312** may further include an insert base **346** and an engagement feature **348** for engagement with a tibial tray (not shown).

The post **330** may have an articulation surface **331** extending around the post **330** on the medial, posterior, lateral, and anterior aspects of the post **330**. The articulation surface **331** may include a medial articulation surface **332**, a lateral articulation surface **334**, an anterior post surface **336**, and a posterior articulation surface **342**. The medial and lateral articulation surfaces **332**, **334** may taper slightly inward from the post superior end **340** to the post base **338** of the post **330** relative to an insert midline vertical axis **2**. However, some embodiments of CCK insert **312** may include no taper of the medial and lateral articulation surfaces **332**, **334**. The medial articulation surface **332** may be continuous with the medial condylar articulation surface **325**, and the lateral articulation surface **334** may be continuous with the lateral condylar articulation surface **327**. The anterior post surface **336** may extend between the medial and lateral surfaces **332**, **334** and may be convexly rounded. The anterior post surface **336** may taper outward from the post superior end **340** to the post base **338** relative to the midline axis **2**, as best seen in FIG. **12F**. In other embodiments of the CCK insert **312**, the anterior post surface **336** may include less taper, more taper, and/or no taper. The post **330** of the CCK insert **312** may be wider and bigger in diameter than the post **30** of PS insert **12**, for example to provide increased stability in the case of removal of the collateral ligaments.

Referring to FIG. **12B**, the boundary of the post superior end **340** may define a rounded rim **344** shaped as a portion of a circle, from a superior perspective. The post superior end **340** and rim **344** may be semi-circular as shown, however the rim **344** may define a circular envelope **347**. The post superior end **340** may be circular and rim **344** may provide increased surface contact and rotational range of motion when coupled and implanted with the PS femoral component **14** in comparison to traditionally shaped posts with a more square or rectangular shaped post. Thus, the rounded post superior end **340** and rim **344** may allow for surface contact with the femoral component **14** in contrast to the mere point or edge contact that is achieved by traditional posts that do not have these features. The CCK insert **312** may be coupled with the PS femoral component **14** to form a constrained condylar knee assembly, and this assembly may be implanted with a suitable tibial baseplate as a constrained condylar knee prosthesis. The CCK insert **312** may also be coupled with the CR femoral component **114** and implanted with a suitable tibial baseplate. Thus, all of the tibial inserts **12**, **212**, and **312** disclosed herein are interchangeable with both the CR femoral component **114** and the PS femoral component **14**. FIG. **13** is a chart showing the potential combinations of components.

The tibial inserts **12**, **212**, **312**, PS femoral component **14** and CR femoral component **114** may be grouped together as

15

a modular knee replacement system and provided as a kit in one or more packages, in one non-limiting example. Another kit may include a CR femoral component **114**, a PS insert **12** and a CR insert **212**, in one or more packages in another non-limiting example. Yet another kit may include a PS femoral component **14**, a PS insert **12**, a CR insert **212**, and a CCK insert **312**, in one or more packages in yet another non-limiting example. However, it will also be understood that other kit embodiments may utilize any of the tibial inserts and/or femoral components described herein in any number or combination, in one or more packages. Furthermore, other components may also be including in any kit described herein, such as suitable tibial baseplate components, patellar components, etc., in one or more packages. It will also be understood that any of the tibial inserts disclosed herein may be formed of vitamin E polyethylene, highly cross linked polyethylene, ultra-high molecular weight polyethylene (UHMWPE), or any other suitable material.

In a method of the disclosure, a patient may initially experience compromise of the anterior cruciate ligament. The ACL may be removed, and a CR type prosthesis may be implanted, including a CR femoral component **114**, a CR insert **212**, and a tibial baseplate component. Later, the same patient may experience compromise of the PCL and may need additional stabilization of the knee joint. The PCL may be removed, the CR tibial insert **212** may be removed, and a PS tibial insert **12** of the disclosure may be inserted between the originally implanted CR femoral component **114** and the tibial baseplate component, thus providing additional stability for the missing PCL. Even later, the same patient may experience instability of the collateral ligaments. The PS tibial insert **12** may be removed, and the CCK tibial insert **312** of the disclosure may be inserted between the originally implanted CR femoral component **114** and the tibial baseplate component. Thus, the patient may progress from a CR knee prosthesis, to a PS knee prosthesis, and finally to a CCK knee prosthesis without requiring replacement of the originally implanted femoral and/or tibial baseplate components. The interchangeability of the inserts **12**, **212**, **312** permit replacement of only the tibial insert component in order to provide increasing levels of support and stability to the knee joint.

In another method of the disclosure, a patient may initially experience compromise of both the ACL and the PCL. These ligaments may be removed, and a PS type prosthesis may be implanted, including a PS femoral component **14**, a PS insert **12**, and a tibial baseplate component. Later, the same patient may experience instability of the collateral ligaments. The PS insert **12** may be removed, and a CCK insert **312** may be inserted between the originally implanted PS femoral component **14** and the tibial baseplate component. Thus, the patient may progress from a PS knee prosthesis to a CCK knee prosthesis without requiring replacement of the originally implanted PS femoral component **14** and tibial baseplate component.

Referring to FIGS. **14** and **15**, another assembly **1010** of the disclosure for an implantable knee prosthesis is shown in various exploded rear views. The assembly **1010** may include a femoral component **1014** and a tibial insert **1012**. The tibial insert **1012** may be further coupled to a tibial baseplate component (not shown) which may also be implanted in a prepared tibia of a patient (not shown). The femoral component **1014** and tibial insert **1012** illustrated in FIGS. **14** and **15** are right side femoral and tibial insert components. Left side femoral and tibial insert components (not shown) would be mirror images of the right side femoral and tibial insert components that are shown in FIGS.

16

**14** and **15**. The femoral component **1014** may also be referred to as a posterior stabilizing femoral component **1014** (or "PS femoral component") and the tibial insert **1012** may also be referred to as a posterior stabilizing tibial insert (or "PS insert").

FIGS. **16A-16D** show the PS insert **1012** of FIGS. **15** and **14** in isolation. The PS insert **1012** may include a fixation side **1020**, which may be an inferior side, opposite an articulation side **1022**, which may be a superior side. The articulation side **1022** may include a medial articulation portion **1024** having a medial condylar articulation surface **1025** and a lateral articulation portion **1026** having a lateral condylar articulation surface **1027**. A central portion **1028** may separate the medial articulation portion **1024** from the lateral articulation portion **1026**. A post **1030** may protrude superiorly from the central portion **1028** and extend from a post base **1038** to a post top **1040** or post superior end. From the anterior perspective (shown in FIG. **16B**) and/or the posterior perspective (shown in FIG. **16A**), the post **1030** may have its maximum medial-lateral or horizontal width toward the top **1040** of the post **1030**, and its minimum medial-lateral or horizontal width toward the base **1038** of the post **1030**. The post **1030** may also be bilaterally symmetrical from the anterior and/or posterior perspectives. A recess **1045** may be formed posterior to the central portion **1028**, between the medial and lateral articulation portions **1024**, **1026**, and may provide room for a posterior cruciate ligament (not shown). The PS insert **1012** may further include an insert base **1046**, which may further include an engagement feature **1048** for engagement with a tibial baseplate component.

Continuing with FIGS. **14-16D**, the post **1030** may have an articulation surface **1031** extending around the post **1030** on the medial, posterior, lateral, and anterior aspects of the post **1030**. The articulation surface **1031** may include a medial articulation surface **1032**, a lateral articulation surface **1034**, an anterior post surface **1036**, and a posterior articulation surface **1042**. The medial and lateral articulation surfaces **1032**, **1034** may be non-parallel to one another and taper inward from the post superior end **1040** to the post base **1038** relative to an insert midline vertical axis **1002**, as shown in FIGS. **16A** and **16B**. As shown in FIG. **16A**, an angle  $\theta$  between the vertical axis **1002** and each tapered surface **1032**, **1034** may be about  $6.5^\circ$ , in at least one embodiment. Since the post **1030** may be bilaterally symmetrical, the angle  $\theta$  may be the same on both the medial and lateral sides **1032**, **1034** of the post **1030**. In other embodiments of the disclosure, angle  $\theta$  may range from about  $6^\circ$  to  $11^\circ$  degrees. The medial articulation surface **1032** may be continuous with the medial condylar articulation surface **1025**, and the lateral articulation surface **1034** may be continuous with the lateral condylar articulation surface **1027**. The anterior post surface **1036** may extend between the medial and lateral surfaces **1032**, **1034** and may be convexly rounded. The anterior post surface **1036** may also taper outward from the post superior end **1040** to the post base **38** relative to the insert midline vertical axis **1002**, as best seen in FIG. **16D**. In other embodiments of the PS insert **1012**, the anterior post surface **1036** may include less taper, more taper, and/or no taper. A midline medial-lateral axis **1004** and a mid-line anterior-posterior axis **1006** are also shown.

Referring to FIG. **16C**, the boundary of the superior end **1040** may define a rounded rim **1044** shaped as a portion of a circle defined by a circular envelope **1047**, as seen from a superior perspective. The superior end **1040** and rim **1044** may have a convex protrusion **1041** toward a posterior end

of the post **1030** as shown, and may permit passage of the posterior cruciate ligament. The circular superior end **1040** with rim **1044** may provide increased rotational range of motion and surface contact against the femoral component **1014** in comparison to traditional posts with a more square or rectangular shape and no rim. Thus, the rounded superior end **1040** and rim **1044** may allow for greater surface contact with the femoral component **1014** in contrast to the mere point or edge contact that is achieved by traditional posts that do not have these features.

The PS femoral component **1014** depicted in FIGS. **14-15** may include augment fixation apertures **1080**, impact driver apertures **1090**, a cam element or cam bar **1050**, and a box structure **1052** for providing posterior stabilization in place of absent ligaments. The cam bar **1050** may include a cam articulating surface **1051** which may contact the posterior articulation surface **1042** of the post **1030** during flexion. An internal articulation surface **1054** may reside on the inside of the box structure **1052** and may contact the post **1030** during articulation and rotation of the knee joint. The internal articulating surface **1054** may be concavely curved, and may contact the rim **1044** of the post **1030** during axial rotation of the knee joint about the post **1030**. The PS femoral component **1014** may further include a medial condyle **1060** having a medial condylar articulation surface **1062**, and a lateral condyle **1064** having a lateral condylar articulation surface **1066**. The medial and lateral condylar articulation surfaces **1062**, **1066** may articulate against the PS insert **1012** medial and lateral articulation surfaces **1025**, **1027** respectively. A gap **1068** may be formed between the medial and lateral condyles **1060**, **1064**, with the cam bar **1050** extending medial-laterally across the gap **1068**. The internal articulation surface **1054** may include a medial portion **1070** continuous with a lateral portion **1072**. In the embodiment depicted, a fixation post **1074** may protrude superiorly from the PS femoral component **1014**. However, in other embodiments of the PS femoral component **1014**, the fixation post **1074** may be absent and/or other fixation features such as posts, spikes, pegs, webs, keels or teeth may be present to affix the PS femoral component **1014** to a prepared femur (not shown).

Referring to FIGS. **17** and **18**, another assembly **1110** embodiment of the disclosure may include the PS insert **1012** of FIGS. **14-16D** coupled with a cruciate retaining femoral component **1114** (or “CR femoral component”). The CR femoral component **1114** may include, a keel **1120**, fixation members **1130**, impact driver apertures **1190**, and medial and lateral condyles **1160**, **1164** with a gap **1168** formed between the condyles **1160**, **1164**. As a CR femoral component **1114**, no cam bar or box may be present. The condyles **1160**, **1164** may include medial and lateral condylar articulation surfaces **1162**, **1166**, and an internal articulation surface **1154** with medial and lateral portions **1170**, **1172**.

The tapered sides **1032**, **1034** of the post **1030** may permit natural articulation of the CR femoral component **1114** with the PS insert **1012**, which may not be achievable if the post **1030** were not tapered. For example, if the post **1030** had straight sides instead of tapered sides, the wider width of the post **1030** at the base of the post **1030** may interfere with the internal articulating surfaces **1170**, **1172** of the condyles **1160**, **1164**. When the PS femoral component **1014** is coupled with the PS insert **1012** to form assembly **1010**, as in FIGS. **14** and **15**, the circular shape of the post superior end **1040** in combination with the tapered medial and lateral surfaces **1032**, **1034** of the post **1030**, may permit the PS femoral component **1014** to articulate relative to the PS

insert **1012** in the manner of a posterior stabilized femoral component. However, when the PS insert **1012** is paired and implanted with the CR femoral component **1114**, the resultant assembly **1110** may provide the native articulation and rotation of a cruciate retaining implant.

Referring to FIGS. **19** and **20**, another assembly **2110** embodiment of the disclosure may include the PS insert **1012** of FIGS. **14-16D** coupled with a cruciate retaining femoral component **2114** (or “CR femoral component”). The CR femoral component **2114** may not include a keel, as opposed to the CR femoral component **1114** shown in FIGS. **17** and **18**, and the CR femoral component **2114** may be configured for cemented and/or cementless fixation to a femoral bone. The CR femoral component **2114** may include fixation members **2130**, impact driver apertures **2190**, and medial and lateral condyles **2160**, **2164** with a gap **2168** formed between the condyles **2160**, **2164**. As a CR femoral component **2114**, no cam bar or box may be present. The condyles **2160**, **2164** may include medial and lateral condylar articulation surfaces **2162**, **2166**, and an internal articulation surface **2154** with medial and lateral portions **2170**, **2172**.

The tapered sides **1032**, **1034** of the post **1030** may permit natural articulation of the CR femoral component **2114** with the PS insert **1012**, which may not be achievable if the post **1030** were not tapered. For example, if the post **1030** had straight sides instead of tapered sides, the wider width of the post **1030** at the base **1038** of the post **1030** may interfere with the internal articulating surfaces **2170**, **2172** of the condyles **2160**, **2164**. When the PS femoral component **1014** is coupled with the PS insert **1012** to form assembly **1010**, as in FIGS. **14** and **15**, the circular shape of the post superior end **1040** in combination with the tapered medial and lateral surfaces **1032**, **1034** of the post **1030**, may permit the PS femoral component **1014** to articulate relative to the PS insert **1012** in the manner of a posterior stabilized femoral component. However, when the PS insert **1012** is paired and implanted with the CR femoral component **2114**, the resultant assembly **2110** may provide the native articulation and rotation of a cruciate retaining implant.

Referring to FIGS. **21A-21E**, an alternative embodiment of a tibial insert **1212** is shown. The tibial insert **1212** may be referred to as a cruciate retaining tibial insert **1212** (or “CR insert”). In a system of the disclosure, the CR insert **1212** may be implanted with the CR femoral components **114**, **1114**, **2114** and a tibial baseplate component (not shown) to form a cruciate retaining knee prosthesis system. The CR insert **1212** may include a fixation side **1220**, which may be an inferior side, opposite an articulation side **1222**, which may be a superior side. The articulation side **1222** may include a medial articulation portion **1224** having a medial condylar articulation surface **1225** and a lateral articulation portion **1226** having a lateral condylar articulation surface **1227**. A central portion **1228** may separate the medial articulation portion **1224** from the lateral articulation portion **1226**. A recess **1245** may be formed posterior to the central portion **1228**, between the medial and lateral articulation portions **1224**, **1226**, and may provide room for a posterior cruciate ligament. The CR insert **1212** may further include an insert base **1246** and an engagement feature **1248** for engagement with a tibial baseplate component.

The CR insert **1212** may be coupled with CR femoral components **114**, **1114**, **2114** to form a cruciate retaining assembly. This cruciate retaining assembly may be implanted with a suitable tibial baseplate as a complete cruciate retaining knee prosthesis. The CR insert **1212** may also be coupled with PS femoral components **14**, **1014** to

form a posterior stabilizing assembly and implanted with a suitable tibial baseplate as a complete posterior stabilizing knee prosthesis.

Referring to FIGS. 22A-22F, another alternative embodiment of a tibial insert 1312 is shown. The tibial insert 1312 may be referred to as a constrained condylar knee (CCK) tibial insert 1312 (or "CCK insert"). The CCK insert 1312 may include a fixation side 1320, which may be an inferior side, opposite an articulation side 1322, which may be a superior side. The articulation side 1322 may include a medial articulation portion 1324 having a medial condylar articulation surface 1325 and a lateral articulation portion 1326 having a lateral condylar articulation surface 1327. A central portion 1328 may separate the medial articulation portion 1324 from the lateral articulation portion 1326. A post 1330 may protrude superiorly from the central portion 1328, and extend from a post base 1338 to a top, or post superior end 1340. From the anterior perspective, as shown in FIG. 22E, and the posterior perspective, as shown in FIG. 22D, the post 1330 may have its maximum medial-lateral or horizontal width at the post superior end 1340 of the post 1330, and its minimum medial-lateral or horizontal width at the post base 1338 of the post 1330. The post 1330 may be bilaterally symmetrical from the anterior and posterior perspectives. The CCK insert 1312 may further include a posterior recess 1345, an insert base 1346, and an engagement feature 1348 for engagement with a tibial tray (not shown). An opening 1350 may be present in the superior surface of the post 1330.

The post 1330 may have an articulation surface 1331 extending around the post 1330 on the medial, posterior, lateral, and anterior aspects of the post 1330. The articulation surface 1331 may include a medial articulation surface 1332, a lateral articulation surface 1334, an anterior post surface 1336, and a posterior articulation surface 1342. The medial and lateral articulation surfaces 1332, 1334 may taper slightly inward from the post superior end 1340 to the post base 1338 of the post 1330 relative to an insert midline vertical axis 1302. However, some embodiments of CCK insert 1312 may include less taper, more taper, and/or no taper of the medial and lateral articulation surfaces 1332, 1334. The medial articulation surface 1332 may be continuous with the medial condylar articulation surface 1325, and the lateral articulation surface 1334 may be continuous with the lateral condylar articulation surface 1327. The anterior post surface 1336 may extend between the medial and lateral articulation surfaces 1332, 1334 and may be convexly rounded. The anterior post surface 1336 may taper outward from the post superior end 1340 to the post base 1338 relative to the midline axis 1302, as best seen in FIG. 22F. In other embodiments of the CCK insert 1312, the anterior post surface 1336 may include less taper, more taper, and/or no taper. The post 1330 of the CCK insert 1312 may be wider and bigger in diameter than the post 30 of PS insert 12, for example to provide increased stability in the case of removal of the collateral ligaments. A midline medial-lateral axis 1304 and a mid-line anterior-posterior axis 1306 are also shown in FIGS. 22D through 22F.

Referring to FIG. 22B, the boundary of the post superior end 1340 may define a rounded rim 1344 shaped as a portion of a circle, from a superior perspective, and may have a convex protrusion toward a posterior end of the post 1330. The post superior end 1340 and rim 1344 may be semi-circular as shown, however the rim 1344 may define a circular envelope 1347. The post superior end 1340 may be circular and the rim 1344 may provide increased surface contact and rotational range of motion when coupled and

implanted with the PS femoral components disclosed herein in comparison to traditionally shaped posts with a more square or rectangular shaped post. Thus, the rounded post superior end 1340 and rim 1344 may allow for greater surface contact with the femoral components 14, 1014 in contrast to the mere point or edge contact that is achieved by traditional posts that do not include these features.

The CCK insert 1312 may be coupled with the PS femoral components 14, 1014 to form a constrained condylar knee assembly, and this assembly may be implanted with a suitable tibial baseplate as a constrained condylar knee prosthesis. The CCK insert 1312 may also be coupled with any of the CR femoral components disclosed herein and implanted with a suitable tibial baseplate. Thus, all of the tibial inserts disclosed herein are interchangeable with all of the CR and PS femoral components disclosed herein.

Any of the tibial inserts, CR femoral components, and/or PS femoral components disclosed herein may be grouped together in any number or combination as one or more modular knee replacement systems or kits. A particular kit may include a CR femoral component, a PS insert, and a CR insert. Yet another particular kit may include a PS femoral component, a PS insert, a CR insert, and a CCK insert. Suitable tibial baseplate components may also be included with any kit. Moreover, any of the tibial inserts disclosed herein may be formed of vitamin E polyethylene, highly cross linked polyethylene, ultra-high molecular weight polyethylene (UHMWPE), and/or the like.

In an example method of the disclosure, a patient may initially experience compromise of the anterior cruciate ligament. The ACL may be removed, and a CR type prosthesis may be implanted, including a CR femoral component, a CR insert, and a tibial baseplate component. Later, the same patient may experience compromise of the PCL and may need additional stabilization of the knee joint. The PCL may be removed, the CR tibial insert may be removed, and a PS tibial insert of the disclosure may be inserted between the originally implanted CR femoral component and the tibial baseplate component, thus providing additional stability for the missing PCL. Even later, the same patient may experience instability of the collateral ligaments. The PS tibial insert may be removed, and the CCK tibial insert of the disclosure may be inserted between the originally implanted CR femoral component and the tibial baseplate component. Thus, the patient may progress from a CR knee prosthesis, to a PS knee prosthesis, and finally to a CCK knee prosthesis without requiring replacement of the originally implanted femoral and/or tibial baseplate components. The interchangeability of the inserts permits replacement of only the tibial insert component in order to provide increasing levels of support and stability to the knee joint.

In another example method of the disclosure, a patient may initially experience compromise of both the ACL and the PCL. These ligaments may be removed, and a PS type prosthesis may be implanted, including a PS femoral component, a PS insert, and a tibial baseplate component. Later, the same patient may experience instability of the collateral ligaments. The PS insert may be removed, and a CCK insert may be inserted between the originally implanted PS femoral component and the tibial baseplate component. Thus, the patient may progress from a PS knee prosthesis to a CCK knee prosthesis without requiring replacement of the originally implanted PS femoral component and tibial baseplate component.

Referring now to FIGS. 23A-B, FIG. 23A is a perspective front view of the femoral component 1014 of FIG. 14 coupled to one or more augments 1082, 1084 of the present

disclosure and FIG. 23B is a medial side view of the femoral component 1014 of FIG. 23A. As briefly mentioned above with reference to FIGS. 14 and 15, the femoral component 1014 may include augment fixation apertures 1080 that may be configured to secure the one or more augments 1082, 1084 to the femoral component 1014, as well as impact driver apertures 1090 configured to receive a femoral component impact driver tool (not shown) to allow a surgeon to press fit the femoral component 1014 to the end of a prepared femur. The augments 1082, 1084 may be secured to the femoral component 1014 with fixation members 1086 and the augments 1082, 1084 may generally act to replace missing and/or compromised femoral bone and allow the femoral component 1014 to be adequately secured to a femoral bone under such conditions.

Referring now to FIGS. 24A-H, a femoral trial component 400 of the disclosure is illustrated in FIGS. 24A-H. In particular, FIG. 24A shows a perspective top view of a femoral trial component of the disclosure, FIG. 24B shows a perspective rear view of the femoral trial component of FIG. 24A, FIG. 24C shows a lateral side view of the femoral trial component of FIG. 24A, FIG. 24D shows a medial side view of the femoral trial component of FIG. 24A, FIG. 24E shows an anterior view of the femoral trial component of FIG. 24A, FIG. 24F shows a posterior view of the femoral trial component of FIG. 24A, FIG. 24G shows a superior view of the femoral trial component of FIG. 24A, and FIG. 24H shows an inferior view of the femoral trial component of FIG. 24A.

The femoral trial component 400 may be referred to as a universal femoral trial component 400 because the femoral trial component 400 may be used as part of a universal femoral trial system for preparing and trialing a femoral bone of a patient (not shown) to receive a plurality of different femoral implant types, as will be discussed in more detail below. The femoral trial component 400 may include a medial condyle 410 having a medial condylar articulation surface 412, a lateral condyle 420 having a lateral condylar articulation surface 422, an attachment aperture 440 located intermediate the medial condyle 410 and the lateral condyle 420, a patellar projection 430 located anterior to the medial condyle 410 and the lateral condyle 420, a patellar articulation surface 432, fixation member drill apertures 470, impact driver apertures 480, medial attachment features 450 proximate the medial condyle 410, and lateral attachment features 460 proximate the lateral condyle 420. The medial attachment features 450 may further include a medial attachment projection 452, a medial attachment aperture 454 formed within the medial attachment projection 452, and a medial attachment recess 456. The lateral attachment features 460 may likewise include a lateral attachment projection 462, a lateral attachment aperture 464 formed within the lateral attachment projection 462, and a lateral attachment recess 466.

In practice, the femoral trial component 400 may be coupled to a partially prepared distal end of a femur (not shown). For example, a partially prepared distal end of a femur may include five distal cuts that are made to the distal end of the femur using standard techniques and tools (not shown) that are well known in the art. These five cuts may be made to correspond in both shape and angle to the five surfaces on the inner portion of the femoral trial component 400, as best seen in FIGS. 24C and 24D. The femoral trial component 400 may then be press fit onto the partially prepared distal end of the femur and the femoral trial component 400 may also be aligned relative to the distal end of the femur in the medial-lateral directions. The femoral

trial component 400 may then be used to further prepare the distal end of the femur and/or perform one or more trial operations with the femoral trial component 400 still in place on the distal end of a femur.

For example, the attachment aperture 440 formed in the femoral trial component 400, along with the medial and lateral attachment features 450, 460, may be configured to receive any of a plurality of removably couplable femoral bone preparation attachments and/or any of a plurality of femoral trial attachments. Example femoral bone preparation attachments may include a posterior stabilizing notch cutting guide assembly 500, an augment cutting guide assembly (not shown), and a drill and broach guide assembly 700, as will be discussed in more detail below. Each of these femoral bone preparation attachments may be configured to removably couple to the universal femoral trial component 400 to allow a femoral bone of a patient to be selectively modified and prepared to receive a selected femoral implant type. Example femoral trial attachments may include a cruciate retaining trial attachment 800 including a cruciate retaining central portion articulation surface 810 and a posterior stabilizing trial attachment 600 including a posterior stabilizing central portion articulation surface 610, as will be discussed in more detail below. The cruciate retaining trial attachment 800 and the posterior stabilizing trial attachment 600 may each be configured to removably couple to the universal femoral trial component 400 to provide a central portion articulation surface 610, 810 above the attachment aperture 440 and allow for trialing of an articulation surface for a selected femoral implant type that includes a medial condylar articulation surface, a lateral condylar articulation surface, and a central portion articulation surface, for the selected femoral implant type. In this manner, the femoral bone preparation attachments and the femoral trial attachments may be used to help finish preparing the femur of the patient to receive any type of femoral component disclosed herein, and/or further perform one or more trial operations with the femoral trial component 400 still in place on the femur, as will be discussed in more detail below.

The femoral trial component 400 shown in FIGS. 24A-H is a right side femoral trial component 400 having a patellar projection 430 with a right angled medial-lateral shape, as best seen in FIGS. 24E and 24F, which mimics the patellar region of a right femur (not shown). Note how the patellar projection 430 angles towards the right in the posterior view of the femoral trial component 400 shown in FIG. 24F and towards the left in the anterior view of the femoral trial component 400 shown in FIG. 24E. A left side femoral trial component (not shown) will have a patellar projection 430 shape that is a mirror image of that shown in FIGS. 24E and 24F, having a left angled medial-lateral shape that mimics the patellar region of a left femur (not shown). In another embodiment of the disclosure illustrated in FIGS. 35A-C, a universal femoral trial component 900 may include a patellar projection 910 with a universal shape that does not angle towards the right or left, but rather, the patellar projection 910 in this embodiment may have a symmetrical medial-lateral shape. In this manner, the universal femoral trial component 900 shown in FIGS. 35A-C has a universal shape that may be used to prepare and trial both right and left side femurs. The patellar projection 910 may have a patellar articular surface 912.

FIGS. 25A-26 illustrate a posterior stabilizing notch cutting guide assembly 500 that may be used with the femoral trial component 400 shown in FIGS. 24A-H to help prepare a femur of a patient to receive a PS femoral component of

the present disclosure by guiding bone resection. In particular, FIG. 25A is a perspective rear view of the posterior stabilizing notch cutting guide assembly 500, FIG. 25B is another perspective rear view of the posterior stabilizing notch cutting guide assembly 500, FIG. 25C is a medial side view of the posterior stabilizing notch cutting guide assembly 500, FIG. 25D is a top view of the posterior stabilizing notch cutting guide assembly 500, and FIG. 26 is a partial exploded view of the posterior stabilizing notch cutting guide assembly 500.

The posterior stabilizing notch cutting guide assembly 500 may include a posterior stabilizing notch cutting guide body 510 that includes a medial member 520 having a medial cutting guide surface 522 and medial channels 524 formed therein, a lateral member 530 having a lateral cutting guide surface 532 and lateral channels 534 formed therein, and a patellar member 540 having a patellar cutting guide surface 542.

The posterior stabilizing notch cutting guide assembly 500 may also include a locking mechanism which may include: a first locking member 552, a second locking member 554, a first release lever 562 coupled to the first locking member 552 via a first pin 572, a second release lever 564 coupled to the second locking member 554 via a second pin 574, a first resilient member 592 located between the first release lever 562 and the posterior stabilizing notch cutting guide body 510, with the first resilient member 592 housed in a first resilient member housing 582, a second resilient member (not shown) similarly located between the second release lever 564 and the posterior stabilizing notch cutting guide body 510, with the second resilient member housed in a second resilient member housing 584.

The first resilient member 592 may be configured to apply a biasing force that acts to push the first locking member 552 away from the posterior stabilizing notch cutting guide body 510 in the medial direction and the second resilient member may be configured to apply a biasing force that acts to push the second locking member 554 away from the posterior stabilizing notch cutting guide body 510 in the lateral direction.

Referring to FIGS. 27A and 27B, the posterior stabilizing notch cutting guide assembly 500 may be removably coupled to the universal femoral trial component 400 by squeezing the first release lever 562 and the second release lever 564 together toward each other (see arrows 501 in FIG. 27A) in order to overcome the biasing forces of the first resilient member 592 and the second resilient member; then inserting the posterior stabilizing notch cutting guide assembly 500 into the attachment aperture 440 of the universal femoral trial component 400 (see arrow 502 in FIG. 27A); and finally releasing the first release lever 562 and the second release lever 564 to allow the biasing forces of the first resilient member 592 and the second resilient member to push the first locking member 552 and the second locking member 554 away from the posterior stabilizing notch cutting guide body 510, causing the first locking member 552 to enter within the medial attachment aperture 454 of the femoral trial component 400 and the second locking member 554 to enter within the lateral attachment aperture 464 of the femoral trial component 400 to couple the posterior stabilizing notch cutting guide assembly 500 to the universal femoral trial component 400, as shown in FIG. 27B.

FIGS. 28A-D illustrate a posterior stabilizing trial attachment 600 that may be used with the femoral trial component 400 shown in FIGS. 24A-H to aid performance of one or more trial operations with the femoral trial component 400 in place on the distal end of the femoral bone. In particular,

FIG. 28A is a perspective rear view of the posterior stabilizing trial attachment 600, FIG. 28B is another perspective rear view of the posterior stabilizing trial attachment 600, FIG. 28C is a perspective front view of the posterior stabilizing trial attachment 600, and FIG. 28D is a perspective side view of the posterior stabilizing trial attachment 600.

The posterior stabilizing trial attachment 600 may include a central portion articulation surface 610, an internal articulation surface 620 having a medial portion 622 and a lateral portion 624, a cam bar element 630 having a cam bar articulating surface 632, a posterior stabilizing box 670, and a gap 640 formed between the medial and lateral portions 622, 624 within the posterior stabilizing box 670. Each of these components of the posterior stabilizing trial attachment 600, such as the posterior stabilizing box 670 and the cam bar element 630, may be configured to allow for trialing of a complete posterior stabilizing femoral implant.

The posterior stabilizing trial attachment 600 may also include attachment projections 650, 660 on the medial and lateral sides of the posterior stabilizing trial attachment 600. The attachment projections 650, 660 may have shapes that are complementary to the medial and lateral attachment features 450, 460 and/or the medial and lateral attachment recesses 456, 466 that are formed in the femoral trial component 400. In this manner, the attachment projections 650, 660 may be configured to couple to the medial and lateral attachment features 450, 460 and/or the medial and lateral attachment recesses 456, 466 formed in the femoral trial component 400, as shown in FIGS. 29A and 29B. This may be accomplished by holding the posterior stabilizing trial attachment 600 above the femoral trial component 400 and moving the posterior stabilizing trial attachment 600 toward the attachment aperture 440 formed in the universal femoral trial component 400 (see arrow 601 in FIG. 29A) until the posterior stabilizing trial attachment 600 is coupled to the femoral trial component 400, as shown in FIG. 29B. In at least one embodiment, the posterior stabilizing trial attachment 600 may be further configured to magnetically couple to the femoral trial component 400.

In this manner, the posterior stabilizing trial attachment 600 may removably couple to the universal femoral trial component 400 and provide the central portion articulation surface 610 above the attachment aperture 440 of the femoral trial component 400 to allow for trialing of a complete articulation surface for a selected femoral implant type, such as a PS femoral component disclosed herein. A complete articulation surface may include a medial condylar articulation surface, a lateral condylar articulation surface, and the central portion articulation surface 610, for the selected femoral implant type.

FIGS. 30A-31 illustrate a drill and broach guide assembly 700 that may be used with the femoral trial component 400 shown in FIGS. 24A-H to help prepare a femur of a patient to receive a femoral component of the present disclosure that utilizes a keel or other bone fixation member that may require a pre-drilled and/or broached bone aperture. In particular, FIG. 30A is a perspective rear view of the drill and broach guide assembly 700, FIG. 30B is a perspective bottom view of the drill and broach guide assembly 700, FIG. 30C is a top view of the drill and broach guide assembly 700, FIG. 30D is a bottom view of the drill and broach guide assembly 700, and FIG. 31 is a partial exploded view of the drill and broach guide assembly 700.

The drill and broach guide assembly 700 may include a drill and broach guide body 710, attachment projections 750, 760, and a drill and broach guide 720. The drill and broach

guide 720 may further include a first drill guide aperture 721, a second drill guide aperture 722, a third drill guide aperture 723, a first broach guide aperture 725 intermediate the first drill guide aperture 721 and the second drill guide aperture 722, and a second broach guide aperture 726 intermediate the second drill guide aperture 722 and the third drill guide aperture 723. The second drill guide aperture 722 may also be located intermediate the first broach guide aperture 725 and the second broach guide aperture 726.

The drill and broach guide assembly 700 may also include a drill and broach guide locking mechanism which may include: a first locking member 742, a second locking member 744, a first release lever 732 coupled to the first locking member 742 via a first pin 752, a second release lever 734 coupled to the second locking member 744 via a second pin 754, and a resilient member 770 located between the first locking member 742 and the second locking member 744 within a locking member housing 780 formed within the drill and broach guide body 710. The resilient member 770 may be configured to apply a biasing force between the first locking member 742 and the second locking member 744 to push the first locking member 742 and the second locking member 744 away from each other.

Referring to FIGS. 32A and 32B, the drill and broach guide assembly 700 may be removably coupled to the universal femoral trial component 400 by squeezing the first release lever 732, and the second release lever 734 together toward each other (see arrows 701 in FIG. 32A) in order to overcome the biasing force of the resilient member 770 between the first locking member 742 and the second locking member 744; then inserting the drill and broach guide assembly 700 into the attachment aperture 440 formed in the universal femoral trial component 400 (see arrow 702 in FIG. 32A); and finally releasing the first release lever 732 and the second release lever 734 to allow the biasing force of the resilient member 770 to push the first locking member 742 and the second locking member 744 away from each other, causing the first locking member 742 to enter within the medial attachment aperture 454 of the femoral trial component 400 and the second locking member 744 to enter within the lateral attachment aperture 464 of the femoral trial component 400 to couple the drill and broach guide assembly 700 to the universal femoral trial component 400, as shown in FIG. 32B. The attachment projections 750, 760 may also have shapes that are complementary to the medial and lateral attachment features 450, 460 and/or the medial and lateral attachment recesses 456, 466 formed in the femoral trial component 400 to aid coupling of the drill and broach guide assembly 700 to the universal femoral trial component 400, as well as magnetic coupling capabilities.

FIGS. 33A-D illustrate a cruciate retaining trial attachment 800 that may be used with the femoral trial component 400 shown in FIGS. 24A-H to aid performance of one or more trial operations with the femoral trial component 400 in place on the distal end of the femoral bone. In particular, FIG. 33A is a perspective front view of the cruciate retaining trial attachment 800, FIG. 33B is a perspective rear view of the cruciate retaining trial attachment 800, FIG. 33C is a perspective bottom view of the cruciate retaining trial attachment 800, and FIG. 33D is a top view of the cruciate retaining trial attachment 800.

The cruciate retaining trial attachment 800 may include a central portion articulation surface 810, an internal articulation surface 820 having a medial portion 822 and a lateral portion 824, and a gap 840 formed between the medial and lateral portions 822, 824. Each of these components of the

cruciate retaining trial attachment 800 may be configured to allow for trialing of a complete cruciate retaining femoral implant.

The cruciate retaining trial attachment 800 may also include attachment projections 850, 860 on the medial and lateral sides of the cruciate retaining trial attachment 800. The attachment projections 850, 860 may have shapes that are complementary to the medial and lateral attachment features 450, 460 and/or the medial and lateral attachment recesses 456, 466 that are formed in the femoral trial component 400. In this manner, the attachment projections 850, 860 may be configured to couple to the medial and lateral attachment features 450, 460 and/or the medial and lateral attachment recesses 456, 466 formed in the femoral trial component 400, as shown in FIGS. 34A and 34B. This may be accomplished by holding the cruciate retaining trial attachment 800 above the femoral trial component 400 and moving the cruciate retaining trial attachment 800 toward the attachment aperture 440 formed in the universal femoral trial component 400 (see arrow 801 in FIG. 34A) until the cruciate retaining trial attachment 800 is coupled to the femoral trial component 400, as shown in FIG. 34B. In at least one embodiment, the cruciate retaining trial attachment 800 may be further configured to magnetically couple to the femoral trial component 400.

In this manner, the cruciate retaining trial attachment 800 may removably couple to the universal femoral trial component 400 and provide the central portion articulation surface 810 above the attachment aperture 440 of the femoral trial component 400 to allow for trialing of a complete articulation surface for a selected femoral implant type, such as a CR femoral component disclosed herein. A complete articulation surface may include a medial condylar articulation surface, a lateral condylar articulation surface, and the central portion articulation surface 810, for the selected femoral implant type.

Any of the components disclosed herein may be included in a modular universal femoral trial kit (not shown) to aid in preparing and trialing a femoral bone of a patient to receive a plurality of different femoral implant types. In at least one embodiment, the modular universal femoral trial kit may include a container (not shown) that contains a femoral trial component 400, 900 and at least one femoral bone preparation attachment, such as the posterior stabilizing notch cutting guide assembly 500 and/or the drill and broach guide assembly 700, as one non-limiting example. In other embodiments, the modular universal femoral trial kit may also include at least one femoral trial attachment, such as the cruciate retaining trial attachment 800 and/or the posterior stabilizing trial attachment 600, as another non-limiting example.

FIG. 36 illustrates a flow chart diagram of a method 3000 for preparing and trialing a femoral bone with a universal femoral trial component 400, 900, according to one embodiment of the present disclosure. The method 3000 will be described in connection with the components and instrumentation described herein. However, those of skill in the art will recognize that alternative implants, assemblies, systems, and instrumentation may be used in the performance of the method 3000.

The method 3000 may begin with a step 3010 in which a universal femoral trial component 400, 900 may be placed on an inferior or distal end of a femoral bone. The distal end of the femoral bone may first be partially prepared with five distal cuts that are made to the distal end of the femur using standard techniques and tools (not shown) that are well known in the art. These five cuts may be made to correspond



in both shape and angle to the five surfaces on the inner portion of the universal femoral trial component **400, 900** (e.g., see FIGS. 24C and 24D). The universal femoral trial component **400, 900** may then be press fit onto the partially prepared distal end of the femur.

In a step **3020**, the universal femoral trial component **400, 900** may be further aligned with respect to the femoral bone along a medial-lateral direction in order to place the universal femoral trial component **400, 900** at a desired medial-lateral location with respect to the femoral bone.

In a step **3030**, one of a plurality of femoral bone preparation attachments may be selected in order to guide resection of portions of the femoral bone, as desired. Example, femoral bone preparation attachments may include the posterior stabilizing notch cutting guide assembly **500** and the drill and broach guide assembly **700**, as two non-limiting examples.

In a step **3040**, the selected femoral bone preparation attachment may be coupled to the universal femoral trial component **400, 900** using techniques described previously herein (e.g., see description related to FIGS. 27A-B and FIGS. 32A-B).

In a step **3050**, the femoral bone may be prepared to receive a desired femoral component by using the selected femoral bone preparation attachment as a guide to resect at least a portion of the femoral bone in order to prepare the femoral bone to receive the desired femoral component. Once the femoral bone has been prepared with the selected femoral bone preparation attachment, the method may move to a step **3060**.

In the step **3060**, the selected femoral bone preparation attachment may be removed from the universal femoral trial component **400, 900**.

In a step **3070**, one of a plurality of femoral trial attachments may be selected in preparation for performing one or more trial operations with the universal femoral trial component **400, 900** still in place on the femoral bone.

In a step **3080**, the selected femoral trial attachment may be coupled to the universal femoral trial component **400, 900** using techniques described previously herein (e.g., see description related to FIGS. 29A-B and FIGS. 34A-B).

In a step **3090**, at least one trial operation may be performed with the selected femoral trial attachment coupled to the universal femoral trial component **400, 900**, and the method **300** may end. For example, the surgeon may perform trialing of articulation surfaces of the knee joint to ensure that the articulation characteristics of the prosthetic knee joint will be satisfactory.

Various steps of any method disclosed herein may be reordered, omitted, and/or replaced with different steps within the scope of the present disclosure. Those of skill in the art, with the aid of the present disclosure, will recognize that many variations may be made to any other method disclosed herein, depending on the particular surgical procedure to be carried out, as well as the configuration of the system used in the performance of that surgical procedure. Moreover, any methods disclosed herein may include one or more steps or actions for performing the described method. These method steps and/or actions may be interchanged with one another. In other words, unless a specific order of steps or actions is required for proper operation of the embodiment, the order and/or use of specific steps and/or actions may be modified.

FIG. 37 illustrates a flow chart diagram of a method **4000** for revising a knee joint prosthesis implanted in a knee of a patient to provide increased stability to the knee joint prosthesis, according to one embodiment of the present

disclosure. The method **4000** will be described in connection with the components and instrumentation described herein. However, those of skill in the art will recognize that alternative implants, assemblies, systems, and instrumentation may also be used in the performance of the method **4000**.

The method **4000** may begin with a step **4010**, in which a first knee joint prosthesis that is implanted in a knee of a patient is surgically accessed. The first knee joint prosthesis may comprise a first tibial insert that is located between a tibial base plate component that is implanted on a tibia of the patient and a femoral component that is implanted on a femur of the patient.

The method **4000** may then proceed to a step **4020**, in which the first tibial insert may be removed from between the tibial base plate component and the femoral component.

The method **4000** may then proceed to a step **4030**, in which a second tibial insert may be inserted between the tibial baseplate component and the femoral component to create a second knee joint prosthesis assembly that is more constrained than the first knee joint prosthesis assembly, and the method **4000** may end.

FIGS. 38A-F and 39 illustrate an example tibial tray **5000** that may be used with any of the tibial inserts and femoral components described herein to create various prosthetic knee assemblies, according to embodiments of the present disclosure. In particular, FIG. 38A shows a perspective front view of the tibial tray **5000**, FIG. 38B shows a perspective rear view of the tibial tray **5000**, FIG. 38C shows an anterior view of the tibial tray **5000**, FIG. 12D shows a posterior view of the tibial tray, FIG. 38E shows a bottom view of the tibial tray **5000**, FIG. 38F shows a top view of the tibial tray **5000**, and FIG. 39 shows an exploded view of an example tibial tray mounting system **6000** that utilizes the tibial tray **5000**.

The tibial tray **5000** may generally include a tibial base plate **5001** that is superiorly mounted on top of a keel **5030**. The tibial base plate **5001** may have a superior end **5010** configured to receive any of the tibial inserts engaged herein, and an inferior end **5020** configured to engage a superior surface of a prepared tibia of a patient (not shown). The superior end **5010** of the tibial base plate **5001** may include a posterior lip **5012** and an anterior lip **5014**, each configured to couple to and retain any of the tibial inserts described herein. The superior end **5010** of the tibial base plate **5001** may also include a tibial insert retaining aperture **5050** configured to receive a tibial insert retaining rod **6010**, which may be used to further couple to and retain a suitable tibial insert to the tibial base plate **5001**, as shown in FIG. 39, provided the tibial insert has a corresponding opening in the post of the tibial insert configured to receive the tibial insert retaining rod **6010** (e.g., see the tibial insert shown in FIGS. 22A-F).

The inferior end **5020** of the tibial base plate **5001** may include one or more spikes **5040** configured to penetrate tibial bone to further couple the tibial base plate **5001** to the superior surface of a prepared tibia. The Keel **5030** may also include a medial fin **5032** and a lateral fin **5034** each configured to penetrate tibial bone and provide additional coupling of the tibial tray **5000** to the tibia. Moreover, in some embodiments the Keel **5030** may also include a tibial stem aperture **5036** configured to receive a tibial stem **6030** and/or a stem adapter member **6020** to further couple the tibial tray **5000** to the tibia of a patient (see FIG. 39). The tibial stem **6030** may be configured to penetrate and reside within an intramedullary canal of the tibia to provide increased fixation of the tibial tray **5000** to the tibia.

It will be understood that the tibial tray **5000** and tibial tray mounting system **6000** shown in FIGS. **38A-F** and **39** are merely one example of a tibial tray and tibial tray mounting system that may be used with the tibial inserts and femoral components described in the present disclosure and that other tibial trays and tibial tray mounting systems are also contemplated herein.

Reference throughout this specification to “an embodiment” or “the embodiment” means that a particular feature, structure or characteristic described in connection with that embodiment is included in at least one embodiment. Thus, the quoted phrases, or variations thereof, as recited throughout this specification are not necessarily all referring to the same embodiment.

Similarly, it should be appreciated that in the above description of embodiments, various features are sometimes grouped together in a single embodiment, Figure, or description thereof for the purpose of streamlining the disclosure. This method of disclosure, however, is not to be interpreted as reflecting an intention that any claim require more features than those expressly recited in that claim. Rather, as the following claims reflect, inventive aspects lie in a combination of fewer than all features of any single foregoing disclosed embodiment. Thus, the claims following this Detailed Description are hereby expressly incorporated into this Detailed Description, with each claim standing on its own as a separate embodiment. This disclosure includes all permutations of the independent claims with their dependent claims.

The word “exemplary” is used herein to mean “serving as an example, instance, or illustration.” Any embodiment described herein as “exemplary” is not necessarily to be construed as preferred or advantageous over other embodiments. While the various aspects of the embodiments are presented in drawings, the drawings are not necessarily drawn to scale unless specifically indicated.

Recitation in the claims of the term “first” with respect to a feature or element does not necessarily imply the existence of a second or additional such feature or element. Elements recited in means-plus-function format are intended to be construed in accordance with 35 U.S.C. § 112 Para. 6. It will be apparent to those having skill in the art that changes may be made to the g details of the above-described embodiments without departing from the underlying principles set forth herein.

The phrases “connected to,” “coupled to” and “in communication with” refer to any form of interaction between two or more entities, including mechanical, electrical, magnetic, electromagnetic, fluid, and thermal interaction. Two components may be functionally coupled to each other even though they are not in direct contact with each other. The term “abutting” refers to items that are in direct physical contact with each other, although the items may not necessarily be attached together. The phrase “fluid communication” refers to two features that are connected such that a fluid within one feature is able to pass into the other feature.

The Figures may show simplified or partial views, and the dimensions of elements in the Figures may be exaggerated or otherwise not in proportion for clarity. In addition, the singular forms “a,” “an,” and “the” include plural referents unless the context clearly dictates otherwise. Thus, for example, reference to a terminal includes reference to one or more terminals. In addition, where reference is made to a list of elements (e.g., elements a, b, c), such reference is intended to include any one of the listed elements by itself, any combination of less than all of the listed elements, and/or a combination of all of the listed elements.

The term “substantially” means that the recited characteristic, parameter, or value need not be achieved exactly, but that deviations or variations, including for example, tolerances, measurement error, measurement accuracy limitations and other factors known to those of skill in the art, may occur in amounts that do not preclude the effect the characteristic was intended to provide.

As used herein, the term “proximal”, “top”, “up” or “upwardly” may refer to a location on the device that is closest to the clinician using the device and farthest from the patient in connection with whom the device is used when the device is used in its normal operation. Conversely, the term “distal”, “bottom”, “down” or “downwardly” may refer to a location on the device that is farthest from the clinician using the device and closest to the patient in connection with whom the device is used when the device is used in its normal operation. Moreover, the terms “upper” and “lower”, and “top” and “bottom”, “front” and “rear” may be used as relative terms herein for ease of description and understanding. It is understood that in embodiments of the disclosure, upper and lower entities may be reversed, as may top and bottom, front and rear.

As used herein, the term “in” or “inwardly” refers to a location with respect to the device that, during normal use, is toward the inside of the device. Conversely, as used herein, the term “out” or “outwardly” refers to a location with respect to the device that, during normal use, is toward the outside of the device.

While specific embodiments and applications of the present disclosure have been illustrated and described, it is to be understood that the scope of this disclosure is not limited to the precise configuration and components disclosed herein. Various modifications, changes, and variations which will be apparent to those skilled in the art may be made in the arrangement, operation, and details of the methods and systems of the present disclosure set forth herein without departing from its spirit and scope.

What is claimed is:

1. A universal femoral trial system for preparing and trialing a femoral bone of a patient to receive a plurality of different femoral implant types, the universal femoral trial system comprising:

a universal femoral trial component comprising:

a medial condyle comprising a medial condylar articulation surface;

a lateral condyle comprising a lateral condylar articulation surface; and

an attachment aperture located intermediate the medial condyle and the lateral condyle, the attachment aperture comprising:

medial attachment features proximate the medial condyle, the medial attachment features comprising at least:

a medial attachment projection; and

a medial attachment aperture formed within the medial attachment projection; and

lateral attachment features proximate the lateral condyle, the lateral attachment features comprising at least:

a lateral attachment projection; and

a lateral attachment aperture formed within the lateral attachment projection; and

a plurality of femoral bone preparation attachments that are each receivable in the attachment aperture and removably attachable to the universal femoral trial component to allow the femoral bone to be modified and prepared to receive a selected femoral implant type,

31

the plurality of femoral bone preparation attachments comprising a drill and broach guide assembly, the drill and broach guide assembly comprising:  
 a drill and broach guide body comprising:  
 a first drill guide aperture; 5  
 a second drill guide aperture;  
 a third drill guide aperture;  
 a first broach guide aperture intermediate the first drill guide aperture and the second drill guide aperture; and 10  
 a second broach guide aperture intermediate the second drill guide aperture and the third drill guide aperture,  
 wherein the second drill guide aperture is intermediate the first broach guide aperture and the second broach guide aperture; and 15  
 a drill and broach guide locking mechanism comprising:  
 a first locking member;  
 a second locking member; 20  
 a first release lever coupled to the first locking member via a first pin;  
 a second release lever coupled to the second locking member via a second pin; and  
 a resilient member located between the first locking member and the second locking member, 25  
 the resilient member configured to apply a biasing force between the first locking member and the second locking member to push the first locking member and the second locking member away from each other, 30  
 wherein the drill and broach guide assembly may be removably coupled to the universal femoral trial component by:  
 squeezing the first release lever and the second release lever together toward each other to overcome the biasing force of the resilient member between the first locking member and the second locking member; 35  
 inserting the drill and broach guide assembly into the attachment aperture formed in the universal femoral trial component; and 40  
 releasing the first release lever and the second release lever to allow the biasing force of the resilient member to push the first locking member and the second locking member away from each other, causing the first locking member to enter within the medial attachment aperture and the second locking member to enter within the lateral attachment aperture to couple the drill and broach guide assembly to the universal femoral trial component. 50

2. The universal femoral trial system of claim 1, wherein the universal femoral trial component further comprises:  
 a patellar projection located anterior to the medial condyle and the lateral condyle, the patellar projection comprising a patellar articulation surface and at least one of:  
 a symmetrical medial-lateral shape;  
 a right angled medial-lateral shape; and  
 a left angled medial-lateral shape; and 60  
 wherein the attachment aperture is further configured to receive:  
 any of a plurality of femoral trial attachments comprising at least one of:  
 a cruciate retaining trial attachment comprising a cruciate retaining central portion articulation surface; and 65

32

a posterior stabilizing trial attachment comprising a posterior stabilizing central portion articulation surface;  
 wherein the cruciate retaining trial attachment and the posterior stabilizing trial attachment are each configured to removably couple to the universal femoral trial component and provide a central portion articulation surface above the attachment aperture to allow for trialing of an articulation surface for the selected femoral implant type, the articulation surface comprising the medial condylar articulation surface, the lateral condylar articulation surface, and the central portion articulation surface, for the selected femoral implant type.

3. The universal femoral trial system of claim 2, wherein the cruciate retaining trial attachment and the posterior stabilizing trial attachment are each configured to magnetically couple to the universal femoral trial component.

4. The universal femoral trial system of claim 2, wherein the posterior stabilizing trial attachment further comprises:  
 a posterior stabilizing box; and  
 a cam bar element comprising a cam bar articulating surface, 20  
 wherein the posterior stabilizing box and the cam bar element are configured to allow for trialing of a complete posterior stabilizing femoral implant.

5. The universal femoral trial system of claim 1, wherein the plurality of femoral bone preparation attachments further comprises a posterior stabilizing notch cutting guide assembly, comprising:  
 a posterior stabilizing notch cutting guide body comprising:  
 a medial cutting guide surface;  
 a lateral cutting guide surface; and  
 a patellar cutting guide surface; and  
 a posterior stabilizing notch cutting guide locking mechanism comprising:  
 a third locking member;  
 a fourth locking member; 25  
 a third release lever coupled to the third locking member via a third pin;  
 a fourth release lever coupled to the fourth locking member via a fourth pin;  
 a second resilient member located between the third release lever and the posterior stabilizing notch cutting guide body, the second resilient member configured to apply a biasing force to push the third locking member away from the posterior stabilizing notch cutting guide body; and  
 a third resilient member located between the fourth release lever and the posterior stabilizing notch cutting guide body, the third resilient member configured to apply a biasing force to push the fourth locking member away from the posterior stabilizing notch cutting guide body, 30  
 wherein the posterior stabilizing notch cutting guide assembly may be removably coupled to the universal femoral trial component by:  
 squeezing the third release lever and the fourth release lever together toward each other to overcome the biasing forces of the second and third resilient members;  
 inserting the posterior stabilizing notch cutting guide assembly into the attachment aperture formed in the universal femoral trial component; and  
 releasing the third release lever and the fourth release lever to allow the biasing forces of the second and 35

33

third resilient members to push the third locking member and the fourth locking member away from the posterior stabilizing notch cutting guide body, causing the third locking member to enter within the medial attachment aperture and the fourth locking member to enter within the lateral attachment aperture to couple the posterior stabilizing notch cutting guide assembly to the universal femoral trial component.

6. A modular universal femoral trial kit for preparing and trialing a femoral bone of a patient to receive a plurality of different femoral implant types, the modular universal femoral trial kit comprising:

- a universal femoral trial component comprising:
  - a medial condyle comprising a medial condylar articulation surface;
  - a lateral condyle comprising a lateral condylar articulation surface; and
  - an attachment aperture located intermediate the medial condyle and the lateral condyle;

- a posterior stabilizing notch cutting guide assembly configured to prepare the femoral bone to receive a posterior stabilized femoral knee implant;

- a posterior stabilizing trial attachment comprising a posterior stabilizing central portion articulation surface; and

- a cruciate retaining trial attachment comprising a cruciate retaining central portion articulation surface;

wherein each central portion articulation surface is configured to cooperate with the medial condylar articulation surface and the lateral condylar articulation surface to simulate articulation of a respective one of the posterior stabilized femoral knee implant and a cruciate retaining femoral knee implant;

wherein each of the posterior stabilizing notch cutting guide assembly, the posterior stabilizing trial attachment, and the cruciate retaining trial attachment is receivable in the attachment aperture and is removably attachable to the universal femoral trial component.

7. The modular universal femoral trial kit of claim 6, wherein the universal femoral trial component further comprises:

- a patellar projection located anterior to the medial condyle and the lateral condyle, the patellar projection comprising a patellar articulation surface and at least one of:
  - a symmetrical medial/lateral shape;
  - a right angled medial/lateral shape; and
  - a left angled medial/lateral shape.

8. The modular universal femoral trial kit of claim 7, wherein the cruciate retaining trial attachment and the posterior stabilizing trial attachment are each configured to magnetically couple to the universal femoral trial component.

9. The modular universal femoral trial kit of claim 7, wherein the posterior stabilizing trial attachment further comprises:

- a posterior stabilizing box; and
  - a cam bar element comprising a cam bar articulating surface,
- wherein the posterior stabilizing box and the cam bar element are configured to allow for trialing of a complete posterior stabilizing femoral implant.

10. The modular universal femoral trial kit of claim 6, wherein the attachment aperture further comprises:
 

- medial attachment features proximate the medial condyle, the medial attachment features comprising at least:

34

- a medial attachment projection; and
- a medial attachment aperture formed within the medial attachment projection; and
- lateral attachment features proximate the lateral condyle, the lateral attachment features comprising at least:
  - a lateral attachment projection; and
  - a lateral attachment aperture formed within the lateral attachment projection.

11. The modular universal femoral trial kit of claim 10, wherein the posterior stabilizing notch cutting guide assembly comprises:

- a posterior stabilizing notch cutting guide body comprising:
  - a medial cutting guide surface;
  - a lateral cutting guide surface; and
  - a patellar cutting guide surface; and

- a locking mechanism comprising:

- a first locking member;
- a second locking member;
- a first release lever coupled to the first locking member via a first pin;

- a second release lever coupled to the second locking member via a second pin;

- a first resilient member located between the first release lever and the posterior stabilizing notch cutting guide body, the first resilient member configured to apply a biasing force to push the first locking member away from the posterior stabilizing notch cutting guide body; and

- a second resilient member located between the second release lever and the posterior stabilizing notch cutting guide body, the second resilient member configured to apply a biasing force to push the second locking member away from the posterior stabilizing notch cutting guide body,

wherein the posterior stabilizing notch cutting guide assembly may be removably coupled to the universal femoral trial component by:

- squeezing the first release lever and the second release lever together toward each other to overcome the biasing forces of the first and second resilient members;

- inserting the posterior stabilizing notch cutting guide assembly into the attachment aperture formed in the universal femoral trial component; and

- releasing the first release lever and the second release lever to allow the biasing forces of the first and second resilient members to push the first locking member and the second locking member away from the posterior stabilizing notch cutting guide body, causing the first locking member to enter within the medial attachment aperture and the second locking member to enter within the lateral attachment aperture to couple the posterior stabilizing notch cutting guide assembly to the universal femoral trial component.

12. The modular universal femoral trial kit of claim 10, further comprising:

- a drill and broach guide assembly, the drill and broach guide assembly comprising:

- a drill and broach guide body comprising:
  - a first drill guide aperture;
  - a second drill guide aperture;
  - a third drill guide aperture;
  - a first broach guide aperture intermediate the first drill guide aperture and the second drill guide aperture; and

35

a second broach guide aperture intermediate the second drill guide aperture and the third drill guide aperture,  
 wherein the second drill guide aperture is intermediate the first broach guide aperture and the second broach guide aperture; and  
 a drill and broach guide locking mechanism comprising:  
 a first locking member;  
 a second locking member;  
 a first release lever coupled to the first locking member via a first pin;  
 a second release lever coupled to the second locking member via a second pin; and  
 a resilient member located between the first locking member and the second locking member,  
 the resilient member configured to apply a biasing force between the first locking member and the second locking member to push the first locking member and the second locking member away from each other,  
 wherein the drill and broach guide assembly may be removably coupled to the universal femoral trial component by:  
 squeezing the first release lever and the second release lever together toward each other to overcome the biasing force of the resilient member between the first locking member and the second locking member;  
 inserting the drill and broach guide assembly into the attachment aperture formed in the universal femoral trial component; and  
 releasing the first release lever and the second release lever to allow the biasing force of the resilient member to push the first locking member and the second locking member away from each other, causing the first locking member to enter within the medial attachment aperture and the second locking member to enter within the lateral attachment aperture to couple the drill and broach guide assembly to the universal femoral trial component.

13. A universal femoral trial system for preparing and trialing a femoral bone of a patient to receive a plurality of different femoral implant types, the universal femoral trial system comprising:  
 a universal femoral trial component comprising:  
 a medial condyle comprising a medial condylar articulation surface;  
 a lateral condyle comprising a lateral condylar articulation surface; and  
 an attachment aperture located intermediate the medial condyle and the lateral condyle;

36

a plurality of guide assemblies collectively configured to prepare the femoral bone to receive a posterior stabilized femoral knee implant or a cruciate retaining femoral knee implant;  
 a posterior stabilizing trial attachment comprising a posterior stabilizing central portion articulation surface; and  
 a cruciate retaining trial attachment comprising a cruciate retaining central portion articulation surface;  
 wherein each central portion articulation surface is configured to cooperate with the medial condylar articulation surface and the lateral condylar articulation surface to simulate articulation of a respective one of the posterior stabilized femoral knee implant and the cruciate retaining femoral knee implant;  
 wherein each of the plurality of guide assemblies, the posterior stabilizing trial attachment, and the cruciate retaining trial attachment is receivable in the attachment aperture and is removably attachable to the universal femoral trial component.

14. The universal femoral trial system of claim 13, wherein the universal femoral trial component further comprises a patellar projection located anterior to the medial condyle and the lateral condyle, the patellar projection comprising a patellar articulation surface and at least one of:  
 a symmetrical medial/lateral shape;  
 a right angled medial/lateral shape; and  
 a left angled medial/lateral shape.

15. The universal femoral trial system of claim 13, wherein the cruciate retaining trial attachment and the posterior stabilizing trial attachment are each configured to magnetically couple to the universal femoral trial component.

16. The universal femoral trial system of claim 13, wherein the posterior stabilizing trial attachment further comprises:  
 a posterior stabilizing box; and  
 a cam bar element comprising a cam bar articulating surface,  
 wherein the posterior stabilizing box and the cam bar element are configured to allow for trialing of a complete posterior stabilizing femoral implant.

17. The universal femoral trial system of claim 13, wherein the attachment aperture further comprises:  
 medial attachment features proximate the medial condyle, the medial attachment features comprising at least:  
 a medial attachment projection; and  
 a medial attachment aperture formed within the medial attachment projection; and  
 lateral attachment features proximate the lateral condyle, the lateral attachment features comprising at least:  
 a lateral attachment projection; and  
 a lateral attachment aperture formed within the lateral attachment projection.

\* \* \* \* \*